

CK ALIEN 400



User Manual

Please study this manual carefully before using the motorcycle at your first time.

FOREWORD

Thank you for choosing our company motorcycle. To ensure you a pleasure and safe riding, please be sure to read this manual carefully before formal operation.

This manual summarized the method of how to use and maintain the model correctly. If you can follow the rules and guidelines of the manual strictly, then your motorcycle could be durable and keep in good condition. The after-sales staff who received specialized training from qualified distribution unit has accumulated rich experience; they will provide you excellent after-sales service with sincere and warm attitude and complete tool equipment.

All the date、 pictures and specifications are of the latest products when this manual published. Due to the continuous improvement and other changes of products, there maybe some discrepancies with the actual condition. We reserve the right to appropriate changes at any time.

CONTENT

| | |
|---|----|
| ONE、NOTICE OF USER | 1 |
| TWO、INSTALLATION POSITION OF COMPONENTS | 4 |
| THREE、CONTROL PART | 8 |
| FOUR、FUEL AND ENGINE OIL RECOMMENDATION | 19 |
| FIVE、NEW CAR RUNNING IN | 21 |
| SIX、INSPECTION BEFORE RIDING | 22 |
| SEVEN、DRIVING THE POINT | 24 |
| EIGHT、INSPECTION AND MAINTENANCE | 29 |
| NINE、TROUBLESHOOTING | 65 |
| TEN、CLEANING AND STORAGE | 69 |
| ELEVEN、TECHNICAL SPECIFICATION | 71 |

ONE、NOTICE OF USER

Safe driving instructions

Motorcycle riding is of great fun and an exciting sport. Motorcycle riding also requires that some extra precautions be taken to ensure a safe riding, you must obey the traffic rules and the following provisions.

■ Wear safety helmet

Safe driving starts from wearing safety helmet, which is an important element of motorcycle driving. Choosing a helmet that meets the safety and quality standards is the first item of riding protection.

■ Riding apparel

Loose and strange clothes will make you uncomfortable and unsafe when driving. You should choose high-quality tight and protective riding clothes.

■ Inspection before riding

Please carefully read the instructions in the section "inspection before driving" in this manual, and check according to the instructions, which can ensure the safety of the driver and passengers.

■ Don't drive with drugs or alcohol

Alcohol and drugs can affect your judgment and reaction time. Do not drink or take drugs before or during driving.

■ Be familiar with your motorcycle
Your driving skills and mechanical knowledge are the foundation of safe driving. First, practice in the open car until you can fully understand the mechanical performance and control method of the car. Remember, practice makes perfect.

■ Know your safe speed and speed limit

Never allow the speed to be too high or the engine speed to be too high at any time. At any time, you should drive within your own familiar range, understand your skill limit, and avoid accidents.

■ Don't refitting

The modification of this type of car without the approval of the manufacturer will cause unpredictable danger. It is also illegal to modify or dismantle the original device of motorcycle at will, which can not guarantee the safety of motorcycle. Users must comply with the traffic management department's regulations on the use of vehicles.

■ Vigilance of driving in rainy days

Pay special attention to driving in cloudy and rainy days. Remember that the braking distance is twice that in sunny days. When driving, avoid the hole cover on the road, mark the paint and oil on the road to avoid slipping. In the case of unclear judgment of road conditions, the driving shall be slowed down.

Loading and accessories information

Incorrect loading or improper modification of the vehicle or improper installation of accessories may cause driving safety hazards, and even safety accidents. Therefore, special care must be taken in loading, modification or installation of accessories.

- In order to reduce the impact on the center of gravity of the motorcycle, all the luggage loaded on the motorcycle should be put as low as possible. The loading weight on both sides of the motorcycle should be balanced, and the luggage beyond the rear of the motorcycle should be avoided.
- Luggage must be firmly fixed to ensure that it does not move left or right during driving. When you feel unstable during driving, you should immediately pull over to check and readjust.
- Do not load too heavy or bulky items. Overload will affect the weight distribution, thus affecting the handling and braking performance of motorcycle.
- Do not install or carry accessories that affect the performance of the motorcycle, please ensure that it will not adversely affect and lighting system, ground level, braking performance, handling and other performance.
- Additional electrical accessories will overload the electrical system. Serious overload may damage the wiring, stop the engine while driving, or even burn the vehicle.

The maximum load capacity of this model is 180kg (including driver, luggage and accessories), which will make your vehicle difficult to operate, increase the braking distance or cause other problems that may cause danger. Remember not to overload!

Serial number location

The vehicle identification number (VIN) and engine number are used when registering motorcycles. When ordering accessories or entrusting special services, this number will help the distributor to provide better services for you.

- Vehicle identification number (VIN)
The vehicle identification number (VIN) is engraved on the steering riser of the frame.



■ Engine number

The engine number is engraved on the left side of the crankcase.



■ Metal plate

The metal plate is fixed on the right vertical pipe of the frame.



Please write down the numbers below for your future reference.

Vehicle identification number (VIN)

Engine number

About information of security

Read and observe this Manual carefully. These terms such as “WARNING”, “CAUTION” and “NOTICE” are used to emphasize intensity of precaution. Please study and understand their meanings thoroughly.

“WARNING”

For warning information, in order to protect you and other people’s safety as well as avoid damaging your motorcycle, this precaution must be read.

“CAUTION”

It is notice information; In order to extend service life of your motorcycle and exert its performance well, please carry out according to notice information.

“NOTICE”

It can help you to use your motorcycle in best of all condition based on its useful information.

TWO、INSTALLATION POSITION OF COMPONENTS

Front visual figure



① Fuel tank cap

② Left handlebar switch

③ Clutch handle

④ Meter

⑤ Wind deflector

⑥ Front brake fluid box

⑦ Front brake handle

⑧ Throttle handle

⑨ Right handlebar switch

⑩ Audio control panel

Left visual figure

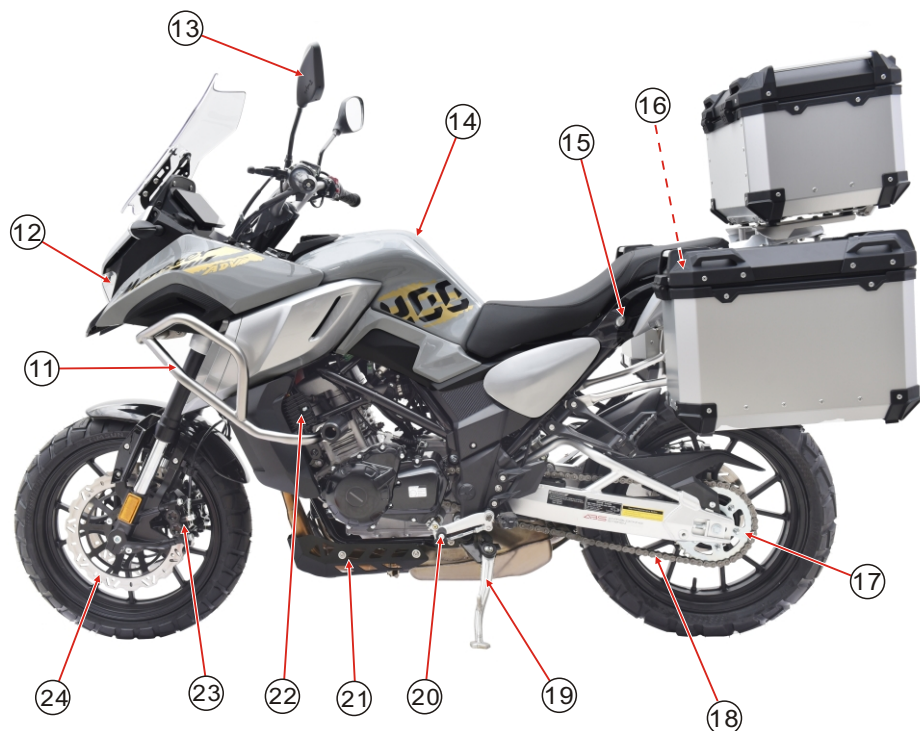

①① Left front bumper

①② Front light

①③ Rearview mirror

①④ Fuel tank

①⑤ Seat lock

①⑥ Rear passenger armrest

①⑦ Rear sprocket

①⑧ Transmission chain

①⑨ Side stand

①⑩ Gearshift lever

①⑪ Engine aluminum baffle

①⑫ Rectifier

①⑬ Front brake (Left)

①⑭ Front brake disc (Left)

Right visual figure



②⑤ Seat

②⑥ Side cover

②⑦ Front turning light

②⑧ Right front bumper

②⑨ Front brake disc (right)

②⑩ Front brake (right)

③① Throttle body assembly

③② Rear brake pedal

③③ Muffler

③④ Rear brake disc

③⑤ Rear brake

Rear visual figure

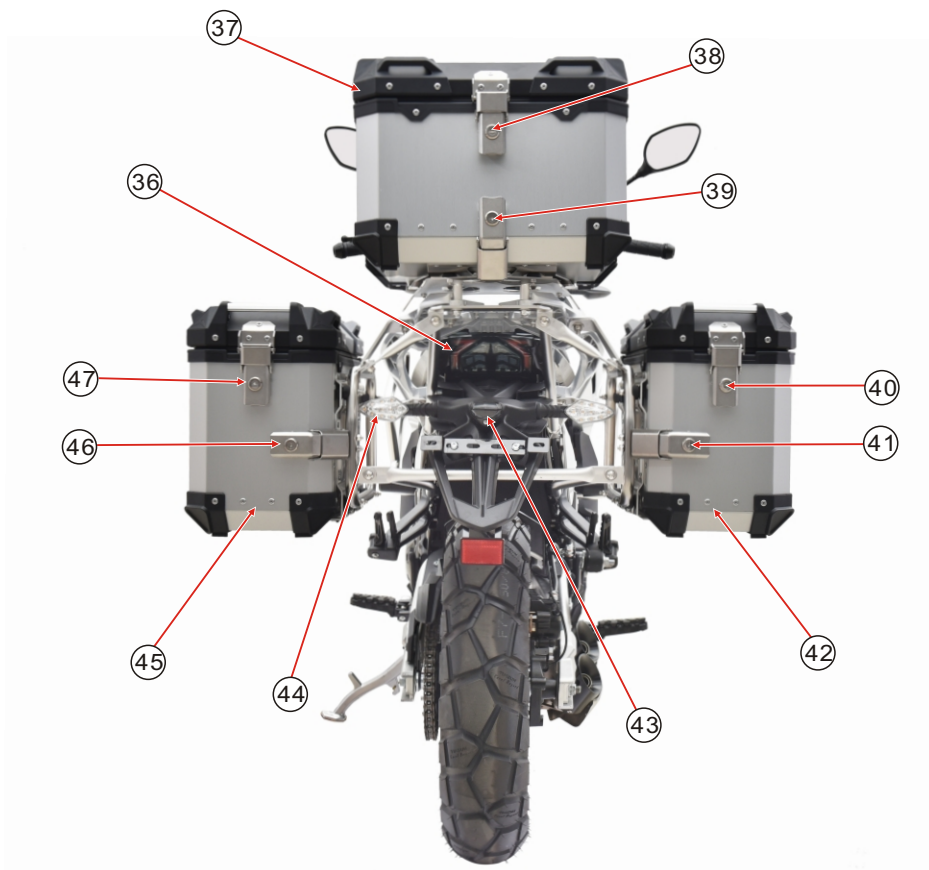

③⑥ Rear lamp

③⑦ Rear stern box

③⑧ Rear trunk cover lock

③⑨ Rear tailgate box fixed lock

④⑩ Right hanging case cover lock

④⑪ Right hanging box fixed lock

④⑫ Right hanging box

④⑬ Rear registration plate lamp

④⑭ Rear turning light

④⑮ Left hanging box

④⑯ Left hanging box fixed lock

④⑰ Left hanging case cover lock

THREE、CONTROL PART

Key



This motorcycle is equipped with two keys and please put one of them in the safe place as the spark key.



Ignition switch



The ignition switch has three positions:

| | |
|---|---|
|  | When the circuit is connected, the engine can be started and the key cannot be removed. |
|  | All circuits are disconnected, the engine cannot be started and the key can be removed. |
|  | Steering locked, engine off, circuit disconnected. |

“” Lock operation

- (1) Turn the steering handle to the left to the end of the left limit.
- (2) Press the key and turn it counterclockwise to position "".
- (3) Remove the key.

WARNING :

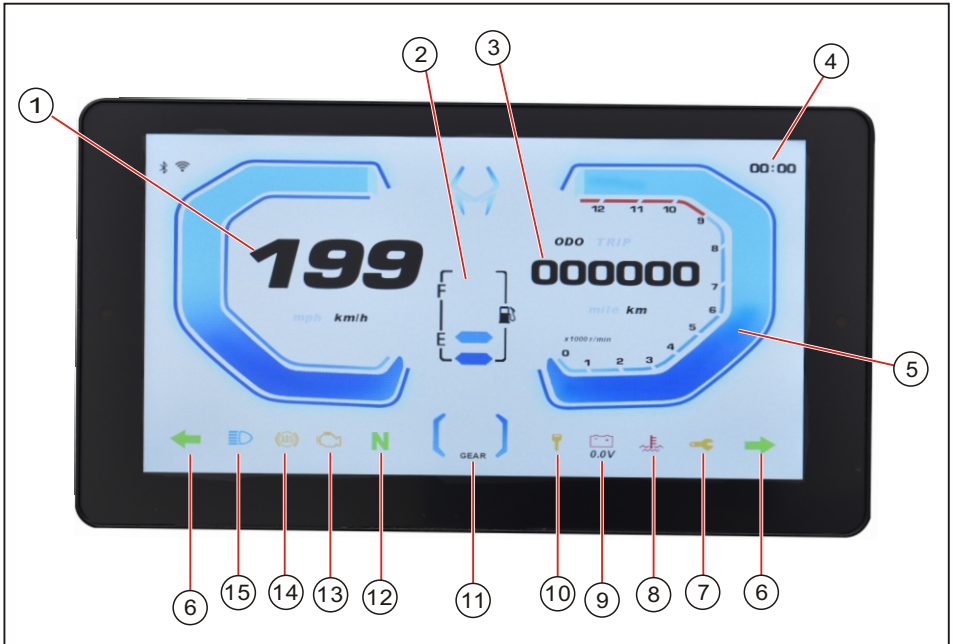

In the steering lock state, you can never push the motorcycle or it will out of balance.

Meter panel



| | |
|-----------------------------------|---|
| <p>① Speedometer</p> | <p>The speedometer indicates the current driving speed in km/h or mph. Metric and English switching: Press the SET key → Press the MODE key → Select unit settings Item → Press the SET key → Choose Metric or English as the display unit.</p> |
| <p>② Oil level indicator</p> | <p>This fuel level meter can indicate the fuel in the fuel tank, it is full when the finger point to the “F” position; it is empty when the finger point the “E” position and you need refueling now.</p> |
| <p>③ ODO meter and TRIP meter</p> | <p>ODO: The main display of the car running total mileage accumulation. TRIP: The short distance meter shows the distance traveled since it was last reset to zero. Short press MODE key: Cyclic switch total mileage (ODO) and subtotal mileage (TRIP) Long press MODE key: Under the interface of subtotal mileage, clear the subtotal mileage.</p> |

| | |
|--|---|
| ④ Clock | <p>Display time.</p> <p>Clock adjustment: Press the SET key → Press the MODE key → Choose Time setup → Press the SET key → Enter adjustment mode</p> |
| ⑤ Tachometer | <p>This meter can indicate the rotate speed of the engine preminute. The red zone in the tachometer is the most limit of the engine rotate speed, it will shorten the life of the engine if it is contial rotate long time in this zone, it should be avoid the finger of the tachometer point to this red zone.</p> |
| ⑥ Turn light indicator | <p>When the turn signals are being operated either to the right or to the left, the indicator will flash at the same time.</p> |
| ⑦ Vehicle maintenance tips | <p>When the indicator flashes, the reminder has reached the mileage of oil replacement. When the total mileage (ODO) accumulates to 500km, the engine lubrication indicator flashes; after the total mileage (ODO) accumulates to 500km , the indicator flashes every 3000km increase (an additional 20km flashes automatically cancel.</p> |
| ⑧ Engine coolant temperature indicator | <p>When the motorcycle is running, the indicator will be on when the coolant temperature is too high. If the indicator light is on, do not let the engine continue to run, otherwise the engine running for too long will cause serious damage due to overheating. When the indicator light is on, please turn off the engine and check the coolant level in the radiator auxiliary water tank after the engine cools down.</p> |
| ⑨ Battery indicator light | <p>Display the battery voltage usage status.</p> |
| ⑩ Key indicator | <p>The key is inserted into the lock of the electric door and transferred to the “  ” (on) position. The indicator light is on.</p> |
| ⑪ Gear indicator | <p>Represents the current gear position of the vehicle, with 1、 2、 3、 4、 5and 6. When shifting the corresponding number will be displayed. When shifting the gear to the neutral position, the neutral indicator ⑫ will light up.</p> |
| ⑫ Neutral indicator light | <p>When this button light, the motorcycle could park safety.</p> |

| | |
|--------------------------------|---|
| <p>⑬ Fault indicator light</p> | <ul style="list-style-type: none"> • When the ignition switch is on and the engine flame out switch is in "  "(off) position, the fault light does not light up. • When the ignition switch is turned on and the engine flameout switch is in the "  "(on) position, the fault light is on. • When the engine starts and runs, if no fault is detected ,the indicator will go out; when the engine is running (or driving), if the fault indicator is long on or flashing, it will detect the failure of the EFI system. At this time, the qualified repairer shall be found to read the fault code to the dealer or maintenance station for inspection and maintenance. |
| <p>⑭ ABS warning light</p> | <p>When the ignition switch is turned to the on position, the ABS (anti lock braking system) warning light will be on, and the warning light will be off after the motorcycle starts to run(start). If the ABS fails, the warning light will be on and on continuously. When the warning light is on, the ABS will not work, but the traditional brake system can still work normally.</p> |
| <p>⑮ High beam indicator</p> | <p>When the high light is used and the overtaking button is pressed, the lamp will turn on.</p> |

 WARNING :

- When the engine coolant indicator is on, it means that the engine is overheated. If you continue to drive when the engine is overheated, the engine components will be seriously damaged.
- For the sake of safety, do not operate the instrument keys while driving a motorcycle.

Left handlebar control system

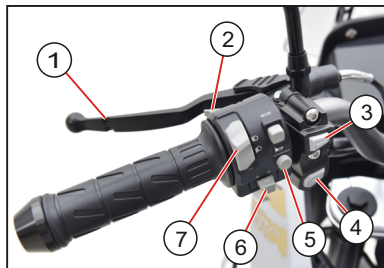

① Clutch handle

When starting the engine, braking or shifting, hold the handle tightly to separate the clutch friction plate to cut off the transmission system.

② Overtaking light switch

Press this switch, the high beam light will be on, and the high beam indicator light on the instrument will also be on. When it is released, it will return to the original state. When it is necessary to overtake, press this button to send a overtaking signal to improve the overtaking safety.

③ MODE key

Used for switching between total mileage(ODO) and short mileage (TRIP), instrument parameter setting option keys, and clock adjustment keys.

④ SET key

Used to enter the instrument parameter setting interface and option confirmation key.

⑤ Horn button

Press the button to sound the horn.

⑥ Turn signal light switch

When the turn signal switch is pushed to the " ← " or " → " position, the turn indicator on the instrument will flash at the same time. To turn off the turn signal, just press the switch inward and then release or pull it to the middle

⑦ Dimmer switch

High beam/city beam operation

When the dimmer switch is moved to the " ≡▷ " (high beam) position, the high beam of the head-lamp will be on , and the high beam indicator on the instrument panel will also be on. On the contrary, when the dimmer switch is moved to the " ≡▷ " (low beam) position, the low beam will be on.



▲ WARNING :

- When you want to change lanes or make a turn, turn on the signal lights in advance. And after a lane change, turn off the signal light in time. Otherwise it may cause an accident.
- When washing the car, do not directly wash the switch button at the handle to avoid poor contact caused by water.

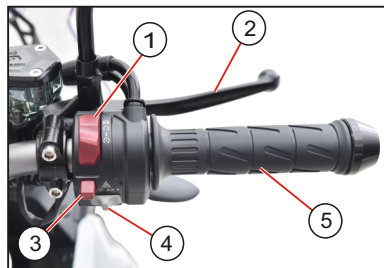
Right handlebar control system



① Engine stop switch

When the ignition switch is opened, if the switch is pressed on the “” position, the ignition circuit is disconnected, the running engine is closed and the stationary engine can not start; When the “” position is pressed on, the circuit is connected, the stationary engine can start at any time; When the “” position is pressed, the engine can start.



② Front brake lever

The front brake handle is located on the right handlebar. If you want to operate the front wheel brake, pull the brake handle towards the driver's handlebar, and the brake tail light will light up automatically. As the car adopts disc hydraulic brake, the grip force does not need to be too large when braking.

③ Double flash

Press this button to flicker the car's steering lights. It is used to remind other vehicles of pedestrians to notice the special situation of the car. Once the switch is pressed, the flicker can be turned off.

④ Light switch

| | |
|---|---|
|  | Daylight off, the headlamp, front position lamp, and rear license plate lamp are on together. |
|  | Daylight, the front position lamp and the rear license plate lamp are on together. |
| ● | All the above lights are off (Except for daytime running lamp and rear position lamp) |

⑤ Throttle grip

The throttle rolling handle is used to control engine speed. Turn the handle toward yourself in clockwise direction to speed up the engine (turn from motorcycle to outside). On the contrary, turn the handle toward yourself in inanti-clockwise direction to slow down the engine speed (turn from motorcycle to outside).

WARNING:

- Do not operate the start button continuously to start the motor, and the longest time is no more than 5 seconds. Otherwise, the circuit and starting motor will be abnormally heated due to a large amount of discharge, and the battery power will temporarily drop. When it cannot be started after several times of opening, stop to check the oil supply system and starting circuit.
- When washing the car, do not directly wash the switch button at the handle to avoid poor contact caused by water.

Tachograph

The car is equipped with a dash cam in the front of the car, and a 32G memory card is attached to the car to ensure our driving safety.



■ Instructions:

1. Software download

Search for “roadcam” in major mobile app markets and download and install it.

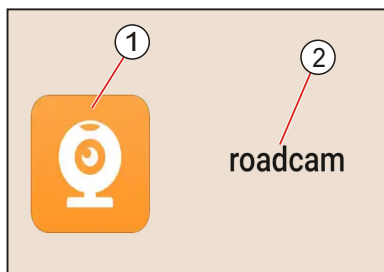

① Software graphics

② Software name

2. Setup connection

(1) Turn on WIFI of mobile phone
(preparation before receiving
signal from device)

(2) Open the switch lock, the whole vehicle is powered on, and the equipment is running.

(3) Click WIFI configuration, enter the WIFI search connection interface, click the WIFI of the driving recorder: SENKE_XXXXXX (XXX XXX is a 6-digit sequential code, which is a combination of numbers and English letters. The effective range of WIFI connection: within 10 meters)

(4) Enter the default login password: 1234567890 to connect. When the connection is successful, the dash cam will automatically update the time of the dash cam.

(5) Open the software "roadcam" and click the camera icon in the middle of the "device interface" to view the video in real time.

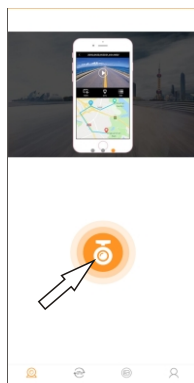

Fuel tank cap

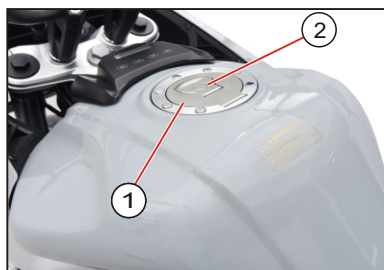

- ① Fuel tank cap
- ② Small cover plate

To open the fuel tank cap ①, first open the small cover plate ②, insert the key into the lock hole, and lift up the fuel tank cap while turning the key clockwise. When closing, put the key with cover into the fuel tank port and press it down until the sound of locking is heard. After the key is reset successfully, pull out the key and finally close the small cover plate.

▲ WARNING :

Before refueling, turn off the engine and make sure there is no one on board. When refueling, no fireworks are allowed. After refueling, please make sure that the fuel tank cap is closed and locked correctly, otherwise the leakage of gasoline may cause fire accident.

▲ NOTICE :

When washing the car, do not flush the fuel tank cap with high-pressure water to avoid water entering the fuel tank.

Audio control panel

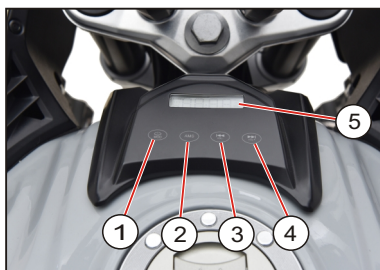

- ① Power switch/Mode switch button
- After electrifying, short press the key to boot, long press this button to shutdown.

Under starting up status, short press to circularly converse according to sequence of “Reception-USB flash disk-BT”. When related equipment fails to connect to the host, the mode corresponding to default device does not participate in circulation.

- ② Pause/ Auto Lock Key

- (1) Under reception status, short press AMS to enter mute status; then short press AMS to recover original volume.
- (2) Under MP3/Bluetooth status, short press AMS to pause; then short press AMS to relieve Pause function.
- (3) Under reception status long press AMS to automatically search and store broadcasting station. When searching broadcasting station **⏪** or **⏩** for automatic storage can store 30 broadcasting stations most.

③ ◀◀ Cue up/Volume down key

(1) Under reception status, short press ◀◀ to select station toward to low frequency; long press ◀◀ to reduce volume.

Under BT/USB flash disk /TF card play status. short press ◀◀ to select the previous one ; long press ◀◀ to reduce volume.

④ ▶▶ Down selections/Volame increase button

(1) Under reception status, short press ▶▶ to select station toward to high frequency; long press ▶▶ to increase volume.

(2) Under BT/USB flash disk /TF card play status. short press ▶▶ to select nest one ; long press ▶▶ to increase volume.

⑤ Display screen

Display reception frequency and current play message.

■ USB socket

The USB socket is located in the back seat of the bottom, as long as the key to open the lock when the rear seat cushion, cushion can be seen in the socket.

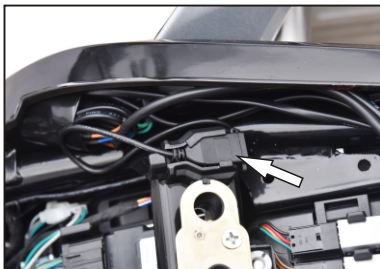

(1) Insert USB flash disk with music into USB socket of host along accordingly direction to enter USB play mode immediately(supporting music in Mp3 /WMA modes).

(2) Only connecting to charging cable under starting up status, can USB socket be used to charge for mobile phones with different brands.

■ Bluetooth operation

Methods of Bluetooth matching:

(1) Open Bluetooth function of Bluetooth, search Bluetooth equipment with mobile phone (the identification name of host Bluetooth is MT 467 B-BT) and conduct matching connection between he mobile phone and searched host.

(2) The initial password of matching is 0000;after successful matching , the host will send warning tone of“Toot”. At such time Bluetooth playis available when you open yourmobile phone’s music player. Note for part mobile phones, there is no need to input matching password and the host will automatically conduct Bluetooth connection after being searched.

(3) Under starting up status, the host can be searched and connected through mobile phone at any time ; after successful connection, it will automatically switch to Bluetooth mode; when the Bluetooth equipment is disconnected, the host may send warning tone of “Toot”

Gear lever

This motorcycle uses six speed transmission. To shift gears correctly, hold the clutch handle and close the throttle while operating the shift lever. Lift up the shift lever to upshift, and press down the shift lever to downshift. Every shift lever is lifted up to advance to one level, otherwise, every shift lever is stepped down to one level. Neutral is between first and second gear. When you need to set neutral, please step up the shift lever to between 1 and 2.

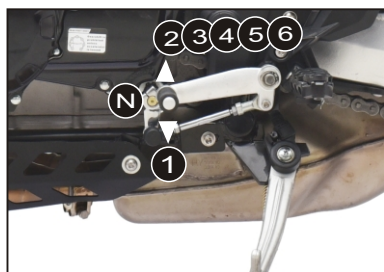

Rear brake pedal

When the rear brake pedal is pressed, the rear wheel brake will be activated and the brake light will be on at the same time. When emergency braking, the front wheel braking and engine braking should be combined to reduce the braking distance.

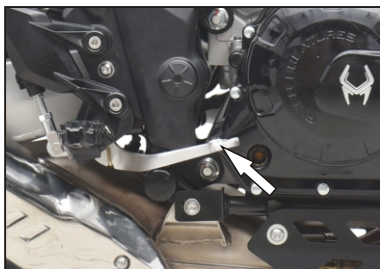

▲ NOTICE :

In order to avoid the damage of engine, speed variator and transmission chain which can't withstand the pounding of mandatory shift in the design of these parts, be sure to use clutch when shift gear.

▲ CAUTION :

When it is in the neutral gear, the indicator on the meter would show the green. Although the light is on, you also need to loosen the clutch level to make sure whether it enter into the neutral position.

Seat cushion lock

Insert the key into the lock hole of the cushion, turn the key anticlockwise, open the lock switch of the cushion, lift up the cushion and remove it. To lock the seat cushion, insert the front clip of the seat cushion and press the rear down until the lock is heard.



▲ NOTICE :

After the seat cushion is installed, pull up-ward to check whether it is locked correctly.

Side stand

When you want to put down the side bracket of the motorcycle, you should put your foot on the load-bearing end of the side bracket facing outwards and step on it with force until the bracket rotates to the lower limit position. After confirmation, you can leave the vehicle . It is necessary to put up the side bracket before driving.



▲ CAUTION :

Please try to park the motorcycle on a solid and flat ground. If you have to park on a slope, turn the front of the motorcycle toward the top of the slope and put the transmission in first gear to reduce the possibility of the side bracket retracting due to movement.

▲ WARNING :

If the side bracket is not fully retracted, it may cause an accident when you turn left. Please check whether it turns to the upper limit position before riding, never stop at other positions. Never ride without lifting the side bracket.

FOUR、 FUEL AND ENGINE OIL RECOMMENDATION

Fuel

Only unleaded gasoline can be used. Gasoline should use octane number 92 or above. If the engine has slight knock or explosion, it may be caused by using ordinary grade fuel as a substitute and should be replaced.

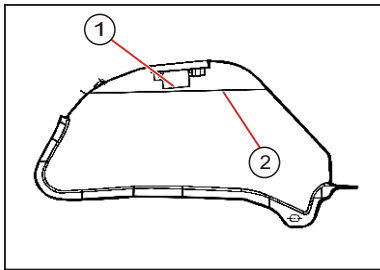

① Fuel tank port

② Fuel level

▲ NOTICE :

Just can use the Un-leaded Petro. If use the leaded Petro, then it will destroy the valve, piston ring and other engine inside parts and emission system seriously.

▲ WARNING :

- Do not overfill. When refueling, make sure that the refueling gun is inserted into the fuel tank, and stop refueling when the gasoline reaches the bottom of the fuel tank. The height of the fuel level ② should not exceed the bottom ① of the fuel tank port, otherwise the gasoline will overflow to the high-temperature engine due to thermal expansion.
- Please refuel in a well ventilated place. Please make sure that the engine has been shut down to avoid gasoline splashing on the hot engine. No smoking, make sure there is no heat or fire around.
- Gasoline is toxic and can cause casualties. Please be very careful when handling gasoline. If you swallow gasoline, inhale too much oil gas or get gasoline in your eyes , please see a doctor immediately. If the skin is stained with gasoline, wash with soap water. clothes. If you get gasoline, please change it immediately.

FIVE、NEW CAR RUNNING IN

The correct running in of new motorcycles is very important for prolonging the service life of motorcycles and giving full play to their performance. The correct methods of running in are listed below.

Maximum speed

The table below shows the maximum recommended engine speed during the running-in.

| | |
|--------------------|------------------|
| Initial 1000km | Below 5000r/min |
| Up to 1000-1600 km | Below 8000r/min |
| Over 1600km | Below 10000r/min |

WARNING :

The new tire is very slippery, which may cause loss of control and injury. It takes 160km running in period to achieve normal tire grip. During running in, avoid hard braking, quick acceleration and sharp turning.

Vary the engine speed

The engine speed should be varied and not held at a constant speed. This allows the parts to be “loaded” with pressure, and then unloaded, allowing the parts to cool. This aids the mating process of the parts. It is essential that some stress be placed on the engine components during running-in to ensure this mating process. Do not, though, apply excess load on the engine.

Circulate the oil before driving

Allow sufficient idling time after warm or cold engine start up before applying load or revving the engine. This allows time for the lubricating oil to reach all critical engine components.

Avoid constant low speed

In the event that the engine runs a long time at constant low speed, components and parts may wear out to cause improper fitting. As long as recommended Max speed isn't exceeded, the driver can enable each shift to accelerate the engine. Initial period within 1000KM, do not over load and you must avoid throttle valve open operation for a long time or any conditions will lead engine overheating.

First regular maintenance and check

The 1000km service is the most important service your motorcycle will receive. During running-in all of the engine components will have worn in and all of the other parts will have seated in. All adjustments will be restored, all fasteners will be tightened, and the dirty engine oil and engine oil filter will be replaced. Timely performance of the 1000km service will ensure optimum service life and performance of the engine.

NOTICE :

After driving 1000km, it is necessary to replace the engine oil and filter element of air cleaner.

SIX、INSPECTION BEFORE RIDING

Always check the following carefully before driving. Never neglect the importance of these checks.

| Test item | Test details |
|-----------------|---|
| Fuel oil | • Check the fuel level in the fuel tank |
| | • Add oil when needed |
| | • Check the fuel system for leaks |
| Engine oil | • Check the engine oil level |
| | • Add oil to the specified level as appropriate |
| | • Check the engine for oil leakage |
| Steering system | • Flexible steering without interference |
| | • There is no movement or looseness |
| Throttle | • Check the throttle free clearance |
| | • Adjust if necessary |
| | • Make sure that the operation is smooth and the return position is correct |
| Clutch | • Check the operation |
| | • Lubricate the cables as necessary |
| | • Check the free clearance of the handle |
| | • Adjust if necessary |
| Brake system | • Check the front and rear brake operation |
| | • Check the brake pads and discs for wear and replace them if necessary |
| | • Check the level in the brake fluid reservoir and add if necessary |
| | • Check the hydraulic system for oil leakage |
| | • Check the free stroke of the rear brake pedal and adjust it if necessary |

| Test item | Test details |
|-----------------------|--|
| Transmission chain | • Check the tightness of the transmission chain |
| | • Adjust if necessary |
| | • Clean and lubricate as required |
| Tire | • Check for damage |
| | • Check tread depth |
| | • Replace if necessary |
| | • Check the tire pressure |
| | • Adjust if necessary |
| Coolant | • Check the coolant level (when the engine is cold) |
| | • Add coolant if necessary |
| | • Check the cooling system for leaks |
| Side stand | • Make sure it works smoothly |
| | • Lubricate the pivot point if necessary |
| Lights and Indicators | • The light can be turned on normally and the indicator light is displayed correctly |
| Horn | • Proper function |
| Brake switch | • Proper function |

SEVEN、 DRIVING THE POINT

WARNING :

- If you are first driving this motorcycle, we suggest you'd better look for a off highway road to practice until you are fully familiar with the control and operation.
- Removing your hands from the handlebars or feet from the footrests during operation can be hazardous. If you remove even one hand or foot from the motorcycle, you can reduce your ability to control the motorcycle. Always keep both hands on the handlebars and both feet on the footrests of your motorcycle during operation.
- To not shift gears as turning and slow down before turning. And the brake and turning ability reduce if the roads damp and tire friction coefficient small, so you must slow down ahead.
- Observe the transportation rules and limit the speed.

Start the engine

- (1) Insert the key into the key hole of the ignition switch and turn it clockwise to the "↻" position to power up the whole vehicle.
- (2) Check and confirm that the vehicle is in the neutral position. If it is in the neutral position, the neutral indicator light (N) on the instrument cluster will be on. If it is in gear, please put the gear in the neutral position to prevent the vehicle from rushing forward during starting.

- (3) Slide the engine flameout switch to "↻" position and stand still for 3 to 5 seconds. Wait for the electrical parts to self check (the oil pump will make a working sound during self check)
- (4) After the self-test, slide the engine flameout switch to the "↻" position to start the engine. When pressing, it is not necessary to turn the throttle control handle.

WARNING :

- Shift into neutral and grasp the clutch before you start the engine . In case that it tuns on as shift in wrong gear.
- Running the engine indoors or in a garage can hazardous. Exhaust gas contains carbon monoxide, a gas that is colorless and odorless and can cause death or sever injury. Do not run it on when nobody there.

NOTICE :

- Do not operate the start button continuously for more than 5 seconds , otherwise the start button will overheat and the battery power will drop temporarily. Wait 15 seconds between each operation of the start button in order to cool the start button and restore the battery power.
- The idling time can not be too long as not driving. otherwise it would damage the inner parts for the hot engine.

The driving

Fold up the side bracket, hold the clutch handle, stop for a moment, pick up the shift lever, shift to the first gear, rotate the throttle handle slowly to its own direction, and release the clutch handle gently at the same time. At this time, the motorcycle will start to move forward. To change to the next higher gear, first slow down, then close the throttle and hold the clutch handle at the same time, use the shift lever to shift to the next higher gear and release the clutch handle, and gradually open the throttle to accelerate. In this way, you can change to the highest gear.

WARNING :

Before starting the vehicle, make sure that the side bracket is in the upper limit position and never stop in other positions.

Using the transmission

The transmission is provided to keep the engine operating smoothly in its normal operating range. The gear ratios have been carefully chosen to meet the characteristics of the engine. The rider should always select the most suitable gear for the prevailing conditions. Never slip the clutch to control road speed but rather downshift to allow the engine to run within its normal operational range.

WARNING :

Never allow the engine rev into the red zone in any gear.

NOTICE :

Don't slide on and dragged the motorcycle over long distances when engine closed for a long time, even transmission in neutral position. Only when the engine is running can you add lubricant to transmission, the improper lubricating will damage transmission.

Riding on hills

When climbing steep hills, the motorcycle may begin to slow down and show lack of power. At this point you should shift to a lower gear so that the engine will again be operating in its normal power range. Shift rapidly to prevent the motorcycle from losing momentum. When riding down a hill, the engine may be used for braking by shifting to a lower gear. Be careful, not to allow the engine to over rev.

NOTICE :

Using transmission shift correctly enables you to control the engine power when accelerating, climbing and so on.

Stopping and parking

- (1) Turn the throttle grip away from yourself to close the throttle completely.
- (2) Evenly using the front and rear brake at the same time, to be sure compensating used at the same time.
- (3) Using transmission device in low gear position to reduce the speed.
- (4) Select neutral with the clutch lever squeezed toward the grip (disengaged position) just before the motorcycle stops. Neutral position can be confirmed by observing the neutral indicator light.
- (5) If the motorcycle to be parked on the side stand on a slight slope, the front end of the motorcycle should face “up” the incline to avoid rolling forward off the side stand. You may leave the motorcycle in 1 gear to help prevent it from rolling off the side stand. Return to neutral before starting engine.
- (6) Turn the ignition key to the “” (off) position.
- (7) Lock the steering for security. Remove the ignition key from the switch.

WARNING :

The engine and muffler will generate high temperatures during normal operation, causing serious burns. Do not touch the hot engine and muffler during normal operation or after stopping the engine.

Engine braking

When you release the throttle handle, the engine brake will help slow down the motorcycle. If you want to be slower, you can downshift to a lower gear. When going downhill on a long and steep slope, the engine brake can be used intermittently to slow down.

Anti lock braking system

ABS is used to prevent the wheels from locking when braking hard in straight travel. ABS can automatically adjust the braking force. The intermittent grip and braking force help to prevent the wheels from being locked when braking and ensure smooth steering control.

The brake control function is the same as ordinary motorcycle. The front brake handle is used for front brake, and the rear brake pedal is used for rear brake. When braking, the front brake handle and the rear brake pedal may rebound slightly, which is normal. Although ABS can prevent the wheels from locking during braking to ensure the stability of the vehicle, the following points should be remembered:

- (1) In order to use the brake effectively, please use the front brake handle and the rear brake pedal at the same time, which is the same as using the traditional motorcycle brake system.
- (2) ABS can not make up for bad road conditions, wrong judgment or improper brake use. You must do the same for motorcycles that are not equipped with ABS.
- (3) ABS is not used to shorten the braking distance, which may lead to longer braking distance on soft, uneven or downhill roads. Therefore, please be more careful in these places.
- (4) ABS can prevent the wheels from locking when braking in a straight line, but it can't control the wheel slip caused by braking when turning. Please slow down before entering the curve.

⚠ WARNING :

Using tires outside the recommended range may cause ABS failure and extend the braking distance. Accidents may happen to drivers. Therefore, when using this motorcycle, be sure to use the recommended standard tires.

⚠ WARNING :

- As vehicle speeds stopping distance increases progressively . Be sure you have a safe stopping distance between you and the vehicle.
- Inexperienced drivers often only use the rear brake, which will accelerate the wear of the brake system and make the braking distance longer and longer.
- Using only the front brake or rear brake is hazardous, it is hard to brake on wet, loose rough, or other slippery surfaces it can cause wheel skid and loss of control.

ABS indicator

Under normal conditions, the ABS indicator light is on when the ignition switch is turned on, and goes out after the motorcycle starts to run. If the indicator shows any of the following conditions, it indicates that one or more failures may have occurred in the ABS. ABS should be checked at the designated dealership or repair station.

- (1) When the ignition switch is turned on, the indicator light does not light up.
- (2) After the motorcycle starts to run, the indicator light is still on.
- (3) After the motorcycle starts to run, the indicator light is on and remains on.
- (4) When the motorcycle is driving, the indicator light is on.

Remember, ABS will not operate when the indicator light is on. But if the ABS fails, the traditional brake system can still operate normally.

EIGHT、INSPECTION AND MAINTENANCE

It is the driver's obligation to make sure safety. Regular checking, adjusting, lubricating your bike, to promise the highest safety, the most efficient condition. Below we will introduce the point of checking, adjusting and lubricating. Each regular checking should set the one as the right which come first, the used months or the mileage. Each checking should follow the method asked, and check the lubricate system and other items carefully. The time of regular checking and lubricate should be the general principle of the normal driving condition. However, it may need to shorten your maintain time according to the weather, land form, location and personal uses difference.

If you motorcycle runs in harsh environment such as sand storm or a condition under which the throttle has to open widely, you should perform special maintenance to ensure its reliability. In this case, your distributor may provide you with further consultation. Because steering system, shock absorber and wheel axel are key parts, they must be serviced and maintained by specially trained technicians. For the sake of safety, we recommend this work be entrusted to your distributor.

CAUTION :

Periodic maintenance may need to change one or two parts, when changing the parts, we suggest you use the original manufactory's parts or the same quality standard parts. Whether you are professional for motorcycle or you have the experience for repairing the motorcycle, you'd better to ask the appointed dealer or the standard maintenance worker to deal with the problem which marked ★ . For the other points which didn't have any mark, you could do it yourself according to our manual.

NOTICE :

The maintenance is the necessary process when the new motorcycle finish running in at 1000km. It could help you using motorcycle safely and had a good specification. You must do the periodic maintenance according to the manual.

Regular inspection and maintenance form

| Item \ Interval | km | Initial 1000 | Every 3000 | Every 6000 |
|---|--------------------------------------|--------------|----------------|------------|
| | Months | Initial 3 | Every 12 | Every 24 |
| Battery | | — | I | I |
| ★ Cylinder bolts and exhaust pipe bolts | | T | T | T |
| ★ Valve clearance | | — | — | I |
| Spark plug | | — | I | C |
| Radiator | | I | I | C |
| Inlet/Outlet pipe | | I | I | I |
| | Replace every four years | | | |
| ★ Coolant | | — | I | — |
| | Every 2 years or 15000km R | | | |
| ★ Engine oil | Every 3000km after the first 500km R | | | |
| Oil filter | Every work 10000km or 250 hours R | | | |
| ★ Throttle body | | I | I | C |
| ★ Fuel filter | | I | C | R |
| ★ Fuel pipe | | I | I | I |
| | Replace every 4 years | | | |
| Air filter (filter element) | | I | Every 3000km C | |
| Clutch handle free travel | | I | I | I |
| Transmission chain | | I | I | I |
| | Clean and Lubricating every 1000km | | | |

| Item \ Interval | km | Initial 1000 | Every 3000 | Every 6000 |
|--|--------|-----------------|------------|------------|
| | Months | Initial 3 | Every 12 | Every 24 |
| ★ Brake | | I | I | I |
| ★ Brake fluid hose | | — | I | I |
| | | Every 4 years R | | |
| ★ Brake fluid | | I | I | I |
| | | Every 2 years R | | |
| Tyre | | I | I | I |
| | | | | |
| ★ Steering mechanism | | — | I | I |
| ★ Front fork | | — | — | I |
| ★ Rear shock absorber | | — | — | I |
| ★ Body and engine fastening bolts and nuts | | T | T | T |

NOTE: I: Inspect C: Clean R: Replace T: Tighten

Lubrication chart

| Time interval Item | Initial 6000km or 6 months | Every 12000km or 12 months |
|---|--|----------------------------------|
| Clutch handle | — | Lubricating grease |
| Clutch cable | Lubricating oil | Lubricating oil |
| Throttle cable | Lubricating oil | Lubricating oil |
| Front brake handle shaft | — | Lubricating grease |
| Side stand (Rotating pivot point) | Lubricating grease | Lubricating grease |
| Transmission chain | Oil once every 1000km (Special lubricating oil) | |
| Brake pedal shaft strength | Lubricating grease or Lubricating oil | — |
| The shift lever axis | — | Lubricating grease |
| Front and rear axle sleeves and rear flat fork axle sleeves | — | Lubricating grease |
| ★Steering | Lubricate every 2 years or 20000km | |

Tools

The tool is located at the bottom of the cushion. Remove the cushion and turn it over.

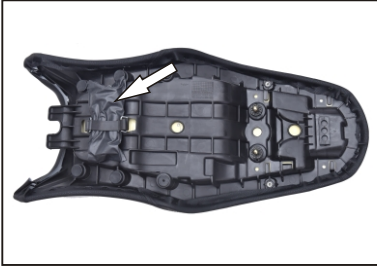

10*12mm、14*17mm open end wrench;

Inner hexagonal tool (No.four、No five and No.six)

Spark plug turnbuckle

Screwdrivers'h andle

Combination all purpose screwdriver ,(can knock down the spark plug together with spark plug turnbuckle;

Battery

The battery is located on the 1 side of the vehicle. This model of motorcycle is equipped with maintenance free battery. Electrolyte has been added to the battery before leaving the factory. It is unnecessary to check the electrolyte level of the battery and add electrolyte. Do not remove the battery seal cover. It is not necessary to remove the seal cover when charging.

NOTICE :

- For the first time, please refer to the instruction manual of the battery.
- When replacing the battery, select the battery with the same model and specification.

■ Removing battery

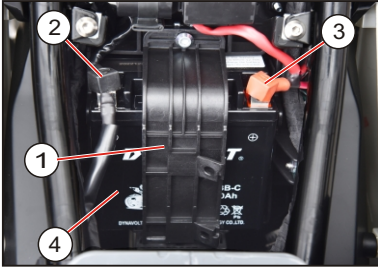

- (1) Make sure the ignition is off.
- (2) Remove the seat cushion
» Refer to the cushion lock section.
- (3) Remove the battery retainer plate (1).
- (4) Remove the negative wire protective cover and remove the negative wire (-) (2).
- (5) Remove the positive wire protector and remove the positive wire (+) (3).
- (6) Remove the battery (4).

■ Clean the battery terminals

- (1) Remove the battery.
- (2) If the terminal just begins to corrode and is covered with white material, clean it with warm water and wipe it clean.
- (3) If the terminals are seriously corroded, clean and polish them with wire brush or sandpaper, and wear goggles during operation.
- (4) After cleaning, replace the battery.

■ Install

Stall the components in the reverse order of removal. Always connect the positive (+) terminal first. Make sure the bolts and nuts are tight.

■ Use and maintenance

- (1) Each starting time cannot exceed 5s. if several starting fails in succession, check fuel supply system and starting and ignition system.
- (2) Frequent starting, short driving distance, Running at low speed for long time, Electrical appliance or bulb beyond rated, all will may cause insufficient discharge or charge to shorten service life.
- (3) In the case of difficult start-up, dimmed light or horn at low sound level, charge the battery immediately.
- (4) If the motorcycle is not used for a long time, please replenish the battery before the motorcycle is stopped, and replenish it once a month. Please use the special charger for motorcycle battery.
- (5) Please scrap batteries by qualified persons or companies deal with can not simply be thrown away, so as not to affect the environment.

▲ WARNING :

The battery will release explosive hydrogen in normal use. This kind of gas is flammable and explosive under specific conditions, even if the battery has been discharged, it still contains hydrogen. Keep the flame and spark away from the battery.

Fuse

The fuse box is set under the seat cushion. There are three back-up fuses in the fuse box for replacement when the original fuse is broken. If the car suddenly goes out and the circuit is not working, you must first check whether the fuse is fused and replace the same ampere of the new fuse.

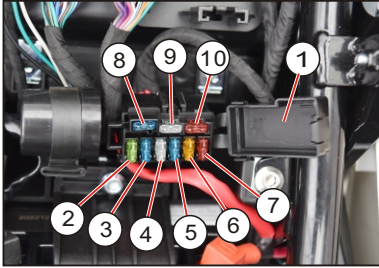

- ① Fuse box cover
- ② Fuse 30A: Vehicle circuit
- ③ Fuse 15A: EFI system
- ④ Fuse 25A: ABS hydraulic control unit motor
- ⑤ Fuse 15A: ABS hydraulic control unit solenoid valve
- ⑥ Fuse 5A: Activate the ABS
- ⑦ Fuse 10A: Vehicle lighting fixtures
- ⑧ Spare fuse :15A
- ⑨ Spare fuse :25A
- ⑩ Spare fuse :10A

■ Check and replace the fuse

- (1) Turn the key to the ignition switch "ⓧ" position and disconnect all circuits.
- (2) Open the fuse box cover.
- (3) Take out the fuse and check whether it is broken.

A: Confirm whether the fuse is damaged by checking whether the fuse is blown.

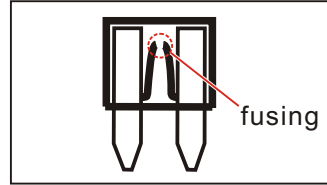

B: If the fuse is blown, be sure to use a fuse of the same specification.

➤ After replacement, turn the key to the "⓪" position, connect the faulty circuit and check whether it operates normally. If the fuse blows again immediately, ask the dealer to check the electrical system.

If the fuse often burns off, there must exist short circuit or an overload situation, and please find the service station to check.

▲ WARNING :

- Do not use a fuse whose rated current is higher than the recommended one, in order to avoid significant damage to electronic systems, even a fire.
- Do not turn off the ignition switch when checking or replacing the fuse, to avoid short circuit. It must conform to the provisions. When replacing the fuse, and don't replace it by other materials.

Air cleaner

Motorcycle air filter is the respiratory system, its role is to clear the air entering the engine contained is the dust and impurities to reduce abnormal wear of the cylinder, piston and piston rings, extending engine life. If the air filter is clogged with dust, intake resistance will become larger, the engine output power will decline, increased fuel consumption, but also make the engine difficult to start, easy to turn off, severe dust into the interior of the cylinder, will aggravate the wear of engine components. So after driving 3000km per the method according to the following steps to check the air filter element and clean.

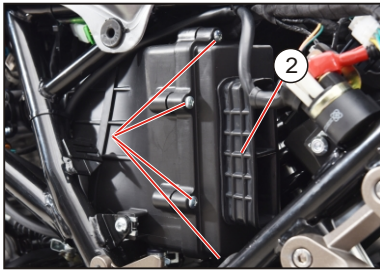

- (1) Remove the seat.
- (2) Remove left side cover and right side cover.
- (3) Remove the air cleaner left outer cover bolt (1) and remove the left outer cover (2).
- (4) Remove the left air cleaner element.
- (5) Remove the air cleaner right outer cover bolt (3) and remove the right outer cover (4).

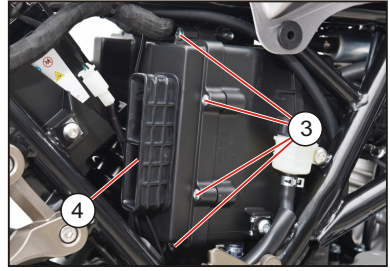

- (6) Remove the right air cleaner element
- (7) Use the method of vibration tapping or shake out most of the dust. Use a compressed air gun carefully to clean the dust on the outer net of the filter element and the paper core.
- (8) Clean the external and internal dust with a brush and remove the blockage in the filter element.
- (9) After cleaning, it should look at the filter is damaged, if breakage, you can use an adhesive patch, if the filter can not be cleaned of serious damage, you should get a new piece.
- (10) Wipe dry with a clean cloth air filter cartridge shell and lumen.
- (11) Reinstall the air cleaner element in reverse order of the removal. Be absolutely sure that the element is securely in position and is sealing properly.

▲ NOTICE :

- This motorcycle air filter using a paper filter, must not use liquid cleaning.
- If the motorcycle often used in dusty conditions, you should clean or replace the filter element frequently.

Spark plug

Spark plugs are important engine components and should be checked regularly. As the heat and deposits will cause the spark plug to be corroded slowly, the spark plug should be removed for inspection according to the regular inspection and maintenance table. In addition, the condition of the spark plug can also explain the condition of the engine. Check whether the color of ceramic insulator around the central electrode of spark plug is normal. If the color of the spark plug is obviously different, it may be caused by the poor operation of the engine. Do not try to diagnose this kind of problem by yourself, but hand it over to the repair shop for inspection. If the spark plug electrode has corrosion, carbon deposit or other defects. Please replace this deposit. The model of spark plug used in each kind of engine is different, mainly due to different calorific value, thread size, etc., so the specified model of spark plug must be used. The spark plug should be cleaned after each trip of 6000km.

■ Remove the spark plug

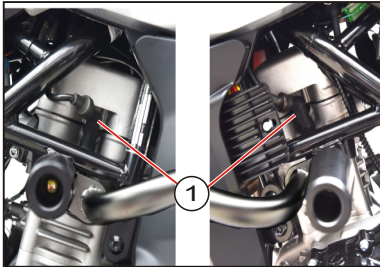

- (1) Pull out spark plug cap ① .
- (2) Place spark plug sleeve and adjust the removal position.
- (3) Turn the spark plug sleeve counterclockwise.
- (4) Remove spark plug.

■ Check and adjust

- (1) Remove the carbon deposit on the spark plug with hard wire or steel needle.

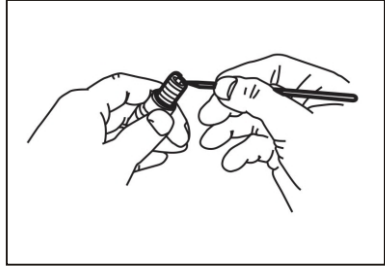

- (2) Check the electrode gap of spark plug with feeler gauge and adjust the gap.

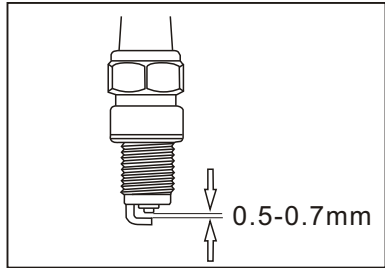

▲ WARNING :

- Incorrect spark plug installation can damage the engine. The engine cylinder head will be damaged if the installation torque of spark plug is too large or the thread is disordered.
- The spark plug must be removed or installed with a special tool, otherwise the ignition coil connector may be damaged.
- Choosing other brands of spark plugs will result in difficult operation. Therefore, negotiate with the distributor first, and then choose other brands of spark plugs.

Engine oil

The durability of the engine depends on the selection of high-quality engine oil and regular replacement of new engine oil. The consumption of engine oil and the decrease of oil quality will vary with driving conditions and service time. Check the engine oil quantity and change the oil regularly before each ride, are the two most important tasks in the maintenance project

■ Check oil level

- (1) Place the motorcycle vertically on the ground with a stable flat arm (support tools such as lifting frame can be used).
- (2) Start the engine and idle for more than 3 minutes.
- (3) Turn off the engine (flame out) and wait for 3 minutes.
- (4) Check the engine oil level through oil inspection window on the right side of the engine.
 - The oil level should be above the window level
 - » If the oil level is not within the specified range:
 - » Add oil

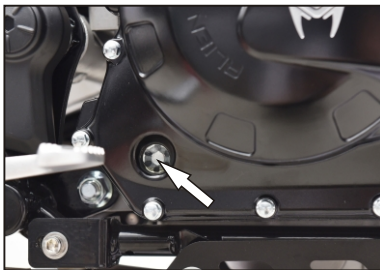

▲ NOTICE :

- When the engine oil is too much or too little, running the engine will damage the engine. If the oil level is too high, use a syringe or other suitable device to remove excess oil from the filler. If the oil level is too low, add the recommended oil to achieve the correct oil level the oil level.
- When the engine oil level is displayed in the engine oil inspection window, if the engine oil level is below or close to the lower limit, the engine cannot be started. Do not exceed the upper limit line when adding oil.

Oil Change

Change the new oil when the engine is warm. Only in this way can the old oil in the engine be drained more thoroughly.

■ Replacement procedure:

- (1) Start the engine and idle for a few minutes to raise the oil temperature.
- (2) Turn off the ignition and wait for 2-3 minutes.
- (3) Park the motorcycle on a stable horizontal surface (the motorcycle can be placed upright by using the lifting frame).
- (4) Place a storage container under the engine oil drain bolt to collect the used oil.
- (5) Remove the engine oil filler cap ①, remove the engine oil drain bolt ②, and drain the engine oil.

- (6) Clean the oil filler cap and oil drain bolt, check whether the O-ring of the oil filler cap is damaged, and replace it if necessary.



- (7) Remove the engine oil filter ③, with the special wrench tool to drain the remaining oil. Make sure that the rubber ring does not stick to the engine.

- (8) Clean the oil filter and the mounting surface on the engine, check the sealing ring for damage and replace it if necessary.



- (9) Apply a thin layer of engine oil to the sealing ring of the oil filter, then install the oil filter and tighten it.
- (10) Refit and tighten the drain bolts.
- (11) Add the recommended oil at the engine oil injection port, and then install the engine oil injection cap.

Oil requirement:

- Only when changing engine oil: 2500ml
- When changing engine oil and oil filter: 2700ml
- Total oil capacity: 3000ml

- (12) Start the engine, idle for a few minutes, and check whether there is oil leakage at the position of the disassembled parts.
- (13) Turn off the engine, wait a few minutes for the oil level to stabilize, and check the oil level through the oil inspection window on the right side of the engine.
 - » Refer to the section checking oil level.

▲ NOTICE :

Do not add any chemical additives to the engine oil. Avoid slipping of the clutch, as engine oil will also lubricate the clutch.

Cooling system

The types of motorcycle equipped with liquid cooling system, greatly improve the heat dissipation capacity of the engine, to ensure that the engine work in the most suitable temperature conditions. The cooling system has a very important influence on the performance and life of the engine. The reasonable maintenance and cooling system can make the engine work in a stable cooling environment and prolong its service life.

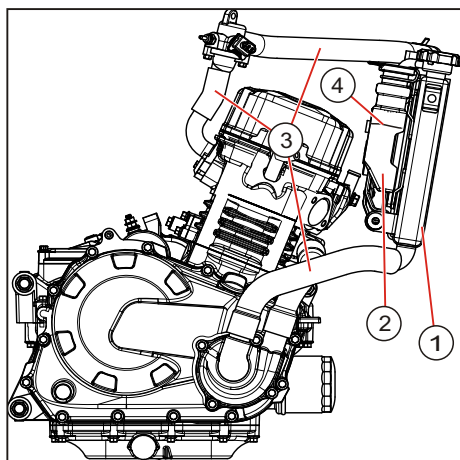

① Radiator

Radiator pipe should be smooth, and the radiating fin should be in perfect condition. Cleaning the dust and mud on fins regularly to ensure good heat dissipation. Please repair or change the injured parts of the pipe and fins time.

⚠ WARNING :

Do not use a high-pressure water gun to clean the radiator, otherwise it will damage the radiator fins and reduce the heat dissipation efficiency of the radiator. If the accessories cannot be installed in front of the radiator or behind the fan, the air flow of the radiator will be blocked or changed, resulting in overheating of the engine and damage to the engine.

② Water tank

Store the coolant needed for cooling system circulation. The secondary water tank is connected with the main water tank, and the coolant will be affected by thermal expansion and contraction. When the engine becomes hot, the coolant of the main water tank will flow into the secondary water tank for temporary preservation when there is too much coolant in the main water tank. When there is too little, the coolant of the secondary water tank will return to the main water tank to maintain a balanced state, and the coolant in the secondary water tank should be kept at half or more of the volume.

③ Water pipe

Hall ensure that each hose connection mouth sealing fastening, and whether there is leakage of periodic inspection of the nozzle and the water whether there are cracks, if necessary to replace.

④ Coolant

Please select the high quality standard of antifreeze, anti boiling, anti-corrosion of the coolant. The main function of the coolant is to provide cooling protection for the engine, reduce the engine temperature, for the engine to continue to work to protect the role of . Do not use the used or expired coolant, otherwise it will lead to the cylinder block, radiator cooling parts, such as premature loss, shorten the service life of the engine.

■ Selection items

- (1) Different types of coolant must not be mixed, to prevent chemical reactions induced by precipitation or corrosion.
- (2) According to the local minimum temperature selection of coolant. Usually, the choice of the freezing point of the coolant temperature should be lower than the local minimum temperature of 5-10 C above, in order to prepare the weather change.

■ Check the coolant

As the amount of coolant will change with the engine temperature, the engine should be allowed to cool before checking the coolant level in the water tank.

- (1) Park the motorcycle on a stable horizontal surface (the motorcycle can be placed upright by using the lifting frame).
- (2) Remove the right radiator tank cover.
- (3) Check the coolant level in the secondary water tank.
- (4) If the coolant level is lower than the minimum mark of the auxiliary water tank, please add it.

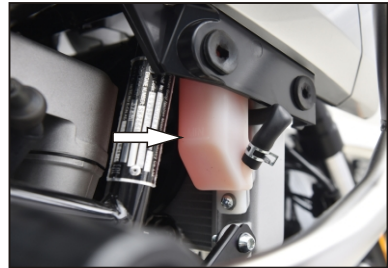

▲ NOTICE :

If the coolant in the auxiliary water tank is empty, repair the cooling system immediately, and then add the coolant.

■ Add coolant

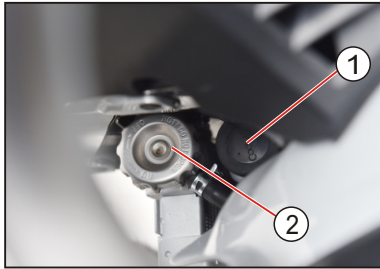

- (1) Open the main tank cover ① and the auxiliary tank cover ② .
- (2) Place a suitable container (e.g. funnel) at the filling port of the water tank, and add coolant into the main water tank until the liquid level rises to the tank opening. If the coolant level is at the tank opening, it is not necessary to add any more.
- (3) Add coolant into the auxiliary water tank until the coolant level rises to half or more of the volume of the auxiliary water tank.
- (4) After adding, twist the main water tank cover ① and cover the auxiliary water tank cover ② .

▲ NOTICE :

In use, if the liquid level decreases due to the leakage of the cooling system, the same type of coolant should be added.

▲ WARNING :

- If the coolant is swallowed or inhaled, it is harmful and hazardous to health. The coolant must not come into contact with skin, eyes or clothing. In case of contact with eyes, rinse immediately with clean water and contact a doctor for treatment. In case of contact with skin or clothing, clean the contact area immediately with soap and water. If swallowed by mistake, immediately to the hospital for treatment. Keep the coolant out of the reach of children and manage it properly.
- Do not open the lid of the water tank at high temperature, so as to avoid the high temperature liquid in the role of pressure and a splash of the cause of burns.

■ Change the coolant

Thy coolant should be replaced regularly according to the regular inspection and maintenance table. it is recommended to entrust the designated distribution department or repair station to replace this work.

- Coolant change time: every 2 years or 15000 km
- Coolant change capacity: 1300ml

Clutch

The free stroke of the end of the clutch rocker arm should be between 10 - 20 mm. If the free stroke is not correct, adjust it as follows:

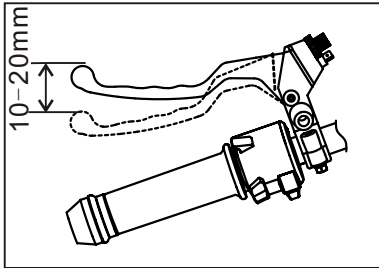

▲ NOTICE :

If the free stroke is not in the range or the stroke is too large, it is very easy to cause premature wear of the clutch.

■ Small scale adjustment

Try to adjust with the upper end regulator of clutch cable.

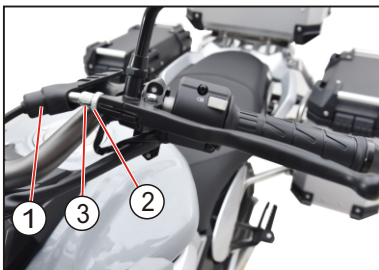

- (1) Remove cable sheath ① .
- (2) Loosen the upper lock nut ② .
- (3) Rotate cable adjuster ③ until the free travel reaches 10-20 mm.
- (4) Tighten the upper lock nut ② and check the free stroke again.
- (5) Re insert cable sheath ① .

■ Long-range ordering

If the upper clutch cable adjuster has been rotated to the limit or cannot be adjusted to the correct free travel, try to use the lower clutch cable adjusting nut for adjustment.

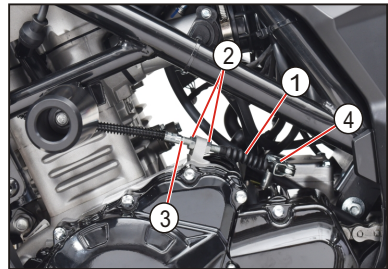

- (1) Remove the cable sheath ① .
- (2) Loosen the lock nut ② of the clutch cable adjusting column.
- (3) Move the cable adjusting column ③ up and down to obtain a proper free stroke.
- (4) Check the tightness of clutch release rocker arm ④ and cable.
- (5) After proper adjustment, tighten the lock nut ② .
- (6) Re insert the cable sheath ① .

▲ NOTICE :

After the adjustment, start the engine and confirm that the clutch will not slip and can be released normally.

Throttle cable clearance

Adjust the clearance:

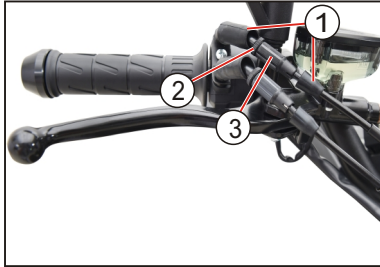

- (1) Remove the cable sheath ① .
- (2) Loosen the lock nut ② .
- (3) Turn the adjuster ③ to adjust the throttle cable clearance to 2-6mm.
- (4) Hold the adjuster in position and tighten the locknut ② .
- (5) Put on the cable sheath ① .



▲ NOTICE :

After the clearance adjustment of the accelerator cable is completed , the throttle rotation handle shall be flexible and reliable, and it shall be sure to return to position automatically.

Transmission chain

Transmission chain is one of the main parts of motorcycle, its quality directly affects the durability, comfort and reliability of motorcycle. The tightness and lubrication of the drive chain must be checked before daily driving. If the transmission chain is too loose or too tight due to excessive wear or improper adjustment, it will cause glue drop or resistance.



▲ NOTICE :

The transmission chain of the car is made of special raw materials. The original products of our factory should be used to replace the chain . Other brands may cause problems. The transmission chain contains a special O-ring.

▲ WARNING :

In order to ensure safety, when the transmission chain is lengthened, it is not allowed to cut it short and then put it back into the vehicle for use. You must contact the dealer or go to the maintenance station to replace it with a new one.

■ Check the transmission chain

The transmission chain must be inspected and lubricated regularly. If you often drive in bad road conditions, at high speed or repeatedly increase the speed quickly, you need to check the transmission chain more frequently. We suggest that when the transmission chain is worn, it is better to entrust the distribution unit or maintenance station to replace the new transmission chain.

When checking the transmission chain, check for the following conditions:

- (1) Is it running smoothly
- (2) Make a strange noise
- (3) Damaged roller
- (4) Loose bolt
- (5) Interference and rusty links
- (6) Excessive wear and tear
- (7) Adjust the wrong chain

The wear of the transmission chain is related to the wear of the sprocket and the driving wheel. When checking the transmission chain, check whether the sprocket and the driving wheel have the following problems:

- (1) Is the sprocket excessively worn
- (2) Are the teeth broken or damaged
- (3) Is the sprocket retaining nut loose

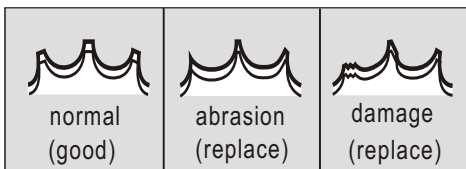

■ Maintenance of transmission chain

The dust of the transmission chain will accelerate the wear of the transmission chain itself and the sprocket, so it should be cleaned and lubricated regularly according to the provisions of the regular inspection and maintenance table. If the transmission chain is dirty, it should be cleaned with dry cloth, cleaning machine (special sealing chain cleaning machine) and soft brush. After cleaning and drying the drive chain, apply lubricating oil (special) on the side of the roller to make it penetrate into the roller and sleeve. Apply lubricating oil on the seal to make it covered by lubricating oil and wipe off the excess lubricating oil.

▲ WARNING :

Do not use steam cleaner, high-pressure cleaner, wire brush, non sealed chain cleaner, gasoline or other chemical detergent to clean the drive chain, otherwise the O-ring seal will be damaged and the drive chain will be damaged.

▲ NOTICE :

- Never use lubricating oil or other non special lubricating oil in the engine, as it may contain substances that may damage the sealing ring.
- After cleaning the vehicle and driving in wet or dusty areas, lubricate the drive chain.

■ Adjust the transmission chain

The transmission chain of motorcycle should be adjusted regularly according to the requirements to keep it in a normal state. In the process of adjustment, it is required to keep a good straight line and tightness. The correct adjustment of the tightness should be to pull the transmission chain up and down by hand. If the transmission chain is too tight or too loose, please adjust the chain to keep the tightness within the range of 10-20 mm of the standard value. If the driving condition is not ideal, the frequency of adjustment should be more frequent than the annual regular maintenance.

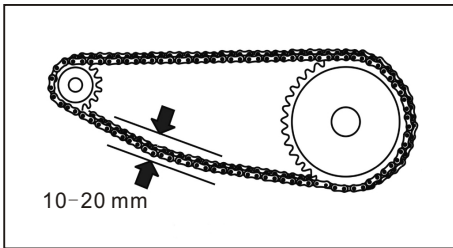

If traveling a long time does not make adjustments the drive chain. Will be stretched due to wear or deformation. Link cause excessive slack off the chain and lead to accidents or serious damage to the engine. Please press the following method to adjust the drive chain.

- (1) Place the motorcycle vertically on the ground with a stable flat arm and keep the rear wheel off the ground (using support tools such as lifting frame).
- (2) Put the transmission in neutral.
- (3) Loosen the rear axle lock nut ①.
- (4) Loosen the lock nuts ② on the left and right.

- (5) Rotate the same number of turns of the adjusting bolts ③ on both sides until the drive chain tightness is adjusted within the standard value.
 - Turn the adjusting bolt counterclockwise to tighten the transmission chain.
 - Turn the adjusting bolt clockwise to loosen the transmission chain.
- (6) Check that the marking line ⑤ on the left and right stop black ④ is in the same position as the rear edge of the adjusting groove to ensure that the drive chain is correctly aligned with the wheel.
 - The markings on both sides should be aligned. If not, rotate the adjusting bolt on the left or right side until the marks on both sides are aligned
- (7) Check the tightness of the transmission chain.
- (8) Re tighten the left and right lock nuts ②.
- (9) Tighten the axle lock nut ①.
- (10) Check the chain tightness again.

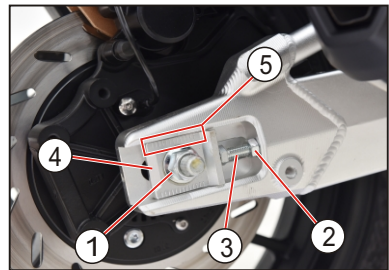

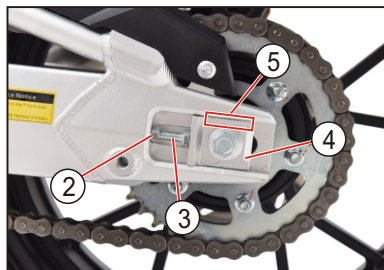

⚠ WARNING :

- Wheel misalignment can cause abnormal wear and may lead to dangerous driving accidents.
- Improper relaxation of transmission chain can make the engine and other important components of the motorcycle overload, chain skid or fracture. To avoid this situation, transmission chain relaxation should keep within the prescribed limit.

⚠ NOTICE :

Except when adjusting the drive chain before and after a good drive chain adjusting the tone scale, but also the application of eye observation chaining and transmission chain is in the same line.

Brake system

This model adopts the brake of front disc brake and rear disc brake. Correct brake operation is very important for safe driving. Remember to check the brake system regularly, which should be completed by qualified maintenance unit.

⚠ WARNING :

If the brake system needs maintenance, we strongly advise you to hand over the work to the maintenance unit. They have a complete range of tools and skilled technology and can do the work in the safest and most economical way.

Before riding every time, please check the following items of the braking system, which takes a short time, and these routine checks help to ensure the safe and reliable driving of the motorcycle.

- (1) Check the front and rear brake system for leaks.
- (2) Check the level of the front and rear brake fluid cups.
- (3) Check the front and rear brake hoses for leakage or damage.
- (4) Check the wear of the front and rear brake pads.
- (5) Check the thickness and wear of the front and rear brake discs.

■ Brake fluid

Check the liquid level position of the front and rear brake fluid reservoirs. When the reservoir is kept horizontal, the brake fluid level must be between the upper and lower level marks. If the water level of the brake fluid in the reservoir is lower than the lower level mark, the brake pads must be checked for wear. If the brake pads are not worn, it may indicate that the brake fluid is leaking. In this case, please send the vehicle to the maintenance station for maintenance of the brake system.

Front:

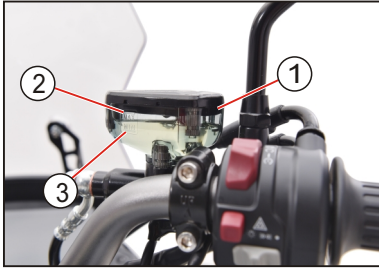

- ① Front brake reservoir
- ② Upper limit marking line MAX
- ③ Lower limit marker line MIN

Rear:

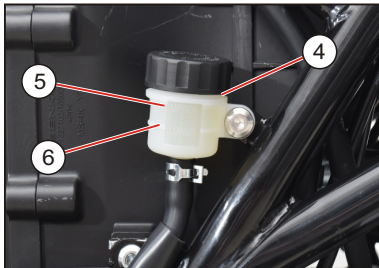

- ④ Rear brake reservoir
- ⑤ UPPER limit marking line
- ⑥ LOWER limit marker line

⚠ WARNING :

Insufficient brake fluid will allow air to enter the brake system, which may lead to ineffective braking. When adding brake fluid, please add the same type of brake fluid. Using different types of brake fluid may cause harmful chemical reaction.

■ Brake pad

Check whether the front and rear brake pads are worn to the limit position. If they are worn to the limit position, please go to the designated service station to replace the front or rear brake pads.

Front: check the brake pads from the front of the brake caliper.

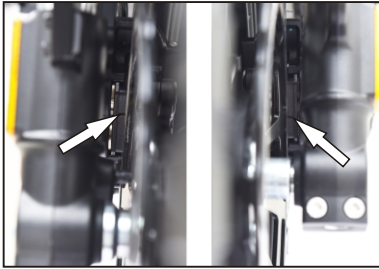

Rear: check the brake pads from the rear of the motorcycle.

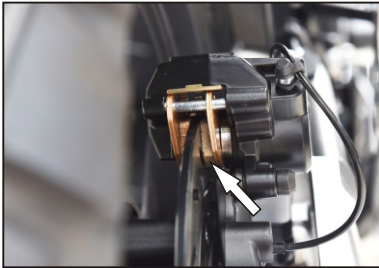

Wear limit position:

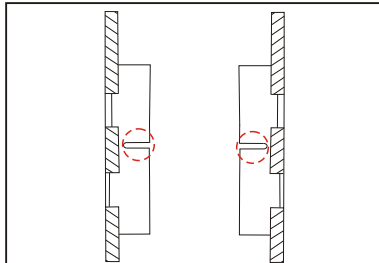

▲ WARNING :

- Don't drive immediately when you just put on a new brake pad. First, operate the brake controller several times to make the brake pad and brake disc fully fit and return to the normal supporting force, and make the brake fluid circulate completely.
- If the brake pads are not in the right position, do not operate the brake controller. If the brake controller is operated, the piston of the brake cylinder will eject and it is difficult to return. If the piston is forced to return, it will lead to the leakage and damage of the brake fluid at the piston.

▲ NOTICE :

If only one of a pair of brake pads is replaced, the braking will not be smooth. When replacing the brake pads, they must be replaced in pairs.

■ Brake disc

The brake disc is an important part of the brake system. In the process of use, it is necessary to check whether the brake disc is damaged, cracked, deformed or the thickness is lower than the specified value. If one of them occurs, please replace it with a new one.

Minimum thickness of brake disc:

| | |
|------------------|-----|
| Front brake disc | 3mm |
| Rear brake disc | 4mm |

Front brake disc(Left)



Front brake disc(Right)



Rear brake disc



▲ WARNING :

- Don't stick grease or get dirty on the friction surface of the brake disc, otherwise it will seriously affect the braking performance and even cause safety accidents.
- After the new brake disc is replaced, the braking distance may be longer than the original braking distance. The best braking effect can be achieved only after 300 km on the right and the brake disc and brake pad are fully run in. Before that, enough braking distance should be reserved when driving.
- Don't drive immediately when you just put on a new brake disc. First, operate the brake controller several times to make the brake pad and brake disc fully fit and return to the normal supporting force, and make the brake fluid circulate completely.

Rear wheel brake

When adjusting the rear wheel brake pedal, first loosen the adjustment nut, set the pedal in the most comfortable position for driving, and then reverse the run adjustment nut to keep the run in the range of 20-30mm.

Adjusting nut

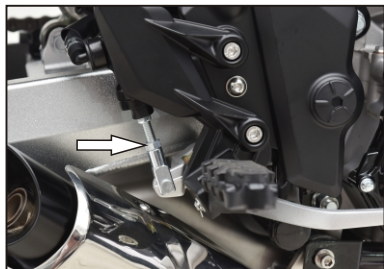

Front / rear brake light switch

The front brake light switch is located under the brake lever. To hold the front brake lever lightly the brake light switch will come on. The rear brake light switch is located beside the rear brake oil hose. It would be lighter when the brake pedal is depressed.

Front



Rear



Tires

You must check the tires before riding every time. Check the tire for cuts, cracks, exposed fabric, nails or other foreign objects embedded in the side or tread of the tire. At the same time, check whether the tread depth in the center reaches the specified limit and whether there is any abnormal bulge or expansion on the sidewall of the tire. During regular maintenance, be sure to check the tire pressure and tread depth. In order to ensure the maximum safety and long service life, in addition to regular maintenance, but also regular inspection.

NOTICE :

Your motorcycle use the tire type are:

Front tire: 110/70-17

Rear tire: 150/60-17

It would bring some problems when using substandard tires . we sincerely recommend that you use the standard tires. The vehicle tire inflation pressure in terms of functionality and security is very important. check tire thread wear condition and tire pressure frequently.

■ Tire pressure

Before each ride, check the tire pressure and adjust it if necessary. Insufficient tire pressure will make it difficult to turn. It will not only accelerate tire wear, but also seriously affect driving stability. If the air pressure is too high, the wheel will slip or even lose control due to the reduction of the contact area between the tire and the ground. It is necessary to keep the tire pressure within the recommended range, and adjust the tire pressure at room temperature.

| Basic parameter \ Name | | Front tire | Rear tire |
|------------------------|-------------|------------|-----------|
| Tire pressure (Kpa) | Just driver | 225 | 225 |
| | Two people | 225 | 225 |

NOTICE :

Tire pressure is affected by ambient temperature and altitude. Therefore, If the temperature or altitude changes during driving, check and adjust the tire pressure.

WARNING :

When the pressure of the tire is felt to drop, check whether the tire is stuck with nails or sharp objects, small holes, and the side of the wheel rim is damaged. Tubeless tires deflate gradually when they have small holes.

■ Tire condition

If you drive a motorcycle with excessively worn tires, the driving stability will be reduced, and you may lose control. Tire wear also affects the shape of the tire and changes the operational performance of the tire. Check the condition and pressure of tires before riding every day. If there are many obvious damage on the tire or the tire is worn to the limit position, the tyre must be replaced.

Wear marks (△T.W.I)

Front:



Rear:



▲ WARNING :

The front and rear tires should be of the same manufacture and design, otherwise different operating characteristics may lead to accidents.

▲ NOTICE :

- The triangle marks indicate the position of the wear strip. If the wear strip touches the ground, the tire has worn to the limit. The tires must be changed.
- After changing the tire, please ride at an appropriate speed first, because the surface of the tire must be run in to give full play to the best characteristics.

Removing wheel

If you need to remove the wheel to replace, repair the tire or replace the brake system components, follow the steps below.

▲ NOTICE :

When you remove and install the wheel, be careful not to damage the wheel speed sensor and ring gear.

- Front wheel
- ■ Remove the front wheel

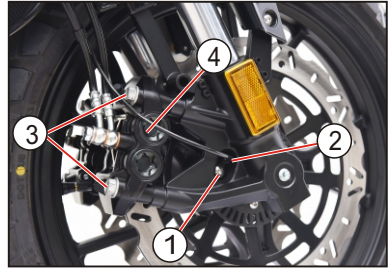

- (1) Use a support tool, such as a front brace or Jack, to jack up the front of the motorcycle until the front tires just leave the ground.
- (2) Remove the wheel speed sensor fixing bolt (1) and remove the wheel speed sensor (2) .
- (3) Remove the front brake caliper fixing bolt (3) and remove the front brake caliper(right) (4) .



- (4) Remove the front brake caliper fixing bolt (5) and remove the front brake caliper(right) (6) .
- (5) Cover the front brake caliper with protective tape or cloth and place it well without twisting the brake hose.

▲ WARNING :

Do not operate the brake handle when removing the front brake caliper. Operating the brake handle will cause the piston of the brake cylinder to eject, and the two brake pads will close, so it is difficult to return. If forced return, it will lead to brake fluid leakage, brake pad damage and other phenomena.

- (6) Loosen axle lock bolt (7) .
- (7) Loosen front axle (8) , rotate and pull the front axle counter clockwise.
- (8) Remove the axle sleeves (9) on the left and right sides of the front wheel.

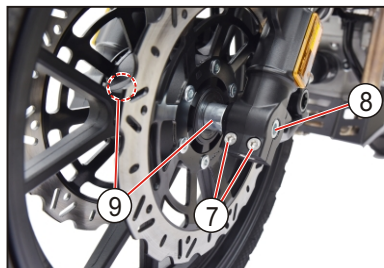

- (9) Move the front wheels forward.

▲ NOTICE :

Avoid getting oil, oil or dirt on brake system components (brake discs, ring gears, or brake pads).

■ Installation:

Install the front wheel in reverse order.

Shaft sleeve position:

Long axle sleeve installation left side (vehicle forward direction)

T-shaped shaft sleeve installation right side (vehicle forward direction)

Torque requirements:

Wheel speed sensor fixing bolt:
12-18 N.m

Front brake caliper retaining bolts :
35-45 N.m

Axle locking bolt : 20-30 N.m

Front axle : 60-70 N.m

▲ WARNING :

After installing the wheel, the incorrect position of the brake pad will affect the braking effect and may cause accidents. Before driving, operate the brake handle repeatedly until the brake pad has a certain pressure on the brake disc when holding the brake handle. You can feel that the handle has returned to the normal grip force. Also check whether the wheels rotate flexibly.

▲ NOTICE :

Before installing the shaft sleeve, please clean the contact surface of the shaft sleeve and apply grease.

■ Rear wheel

■ ■ Remove the rear wheel

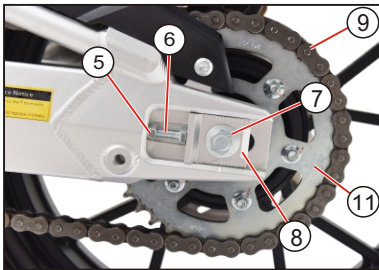
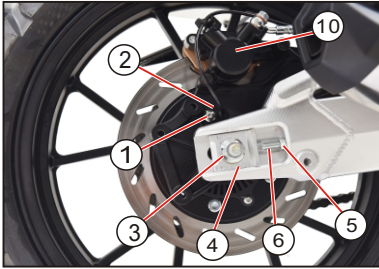

- (1) Use a support tool (e.g. lifting frame) to support the rear of the motorcycle so that the rear tires are raised from the ground.
- (2) Remove the wheel speed sensor fixing bolt (1) and remove the wheel speed sensor (2).
- (3) Loosen the rear axle lock nut (3), left and right lock nuts (5), and rotate the adjusting bolt (6) to move the rear wheel forward to the maximum transmission chain sag.
- (4) Remove the rear axle lock nut (3) and the right chain adjuster aluminum block (4).
- (5) Lift the rear wheel, pull out the rear axle (7), and remove the left chain adjuster aluminum block (8).

- (6) Push the rear wheel forward to remove drive chain (9) from the sprocket.
- (7) Move the rear wheels slightly backward.
- (8) Remove the axle sleeves on both sides, the brake caliper mounting plate (10) and the rear wheel chain seat (11).
- (9) Move the rear wheels out to the rear.

⚠ WARNING :

Do not operate the rear brake pedal when removing the rear wheels. After operating the brake pedal, the piston of the brake cylinder will be ejected, and the two brake pads will be closed, so it is difficult to return. If forced return, it will lead to brake fluid leakage, brake pad damage and other phenomena.

⚠ NOTICE :

Avoid getting oil, oil or dirt on brake system components (brake discs, ring gears, or brake pads).

■■ Installation :

Install the rear wheels as the reverse of the removal procedure.

Shaft sleeve position:

Long axle sleeve installation left side (vehicle forward direction)

Short axle sleeve installation right side (vehicle forward direction)

Adjust the tightness of the transmission chain

» Refer to adjusting the drive chain section

Torque requirements:

Wheel speed sensor fixing bolt : 12-18 N.m

Lock nut: 20-30 N.m

Axle lock nut: 60-70 N.m

▲ NOTICE :

Before installing the shaft sleeve, please clean the contact surface of the shaft sleeve and apply grease.

Precautions for brake caliper installation:

Make sure that the groove on the brake caliper mounting plate is accurately placed on the protrusion of the rear fork rocker arm.

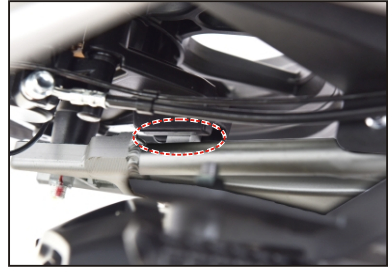

▲ WARNING :

After the wheel is installed, the incorrect position of the brake disc will affect the braking effect and may cause an accident. Before driving, repeatedly operate the rear brake pedal until the brake disc has certain pressure when the rear brake pedal is stepped down, and the tension to return to normal can be felt. Also check whether the wheels rotate flexibly.

Headlamp、Rearlamp、Turning light

The Front lamp, Rear lamp and turning lamp assembled in this car are all LED lamps, which are more durable than ordinary bulbs. However, due to its structural relationship, the damage needs to be replaced as a whole. In case of abnormal situation, it is recommended that you do not repair it by yourself. Please submit it to the local distribution order for completion.

▲ NOTICE :

Prior to operation of any electrical component, you must turn it off to avoid short circuit. When replacing a bulb, you must comply with manufacturer's instruction to avoid injury and damage.

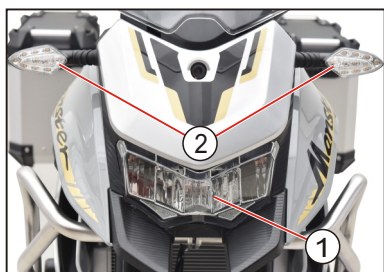

- ① Front light
- ② Front turning lights

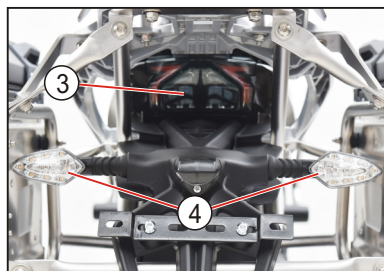

- ③ Rear lamp
- ④ Rear turning lights

EFI system

■ ECU

The ECU is located under the seat cushion and can be seen when the seat cushion is removed. This part is the core component of the EFI system. Its function is to obtain information from various sensors, determine the current state of the engine, send out fuel injection and ignition signals, avoid collision, rain immersion and storage in a strong electromagnetic environment when driving. The damage of ECU will make the vehicle unable to travel far.

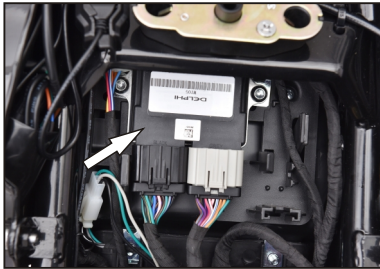

Matters needing attention :

- (1) When assembling ECU and wiring harness connector, it is necessary to ensure that the power supply of the system is disconnected, and the ECU should not be unplugged when the ignition switch is open.
- (2) Avoid contacting exposed parts of ECU pin or ECU wire harness with any part of the body under live condition.

- (3) ECU belongs to the electronic components, is generally not easy to failure, as a failure, the need for special equipment can be detected, but also in general can only replace the module. Users in the use of the process can not be arbitrarily removed unloading, so as not to damage ECU. Maintenance only need to check whether the wire out or worn, wire harness plug connection is in place can prevent damage to ECU due to severe vibration under, in order to prevent the ECU of the outside cover parts rupture, percussion vibration, disassembly should gently. When the first motorcycle to pay attention to the protection of ECU, must not use tap water to wash, so as to avoid ECU caused by a short circuit or a short circuit or poor contact and other phenomena caused by the vehicle can not be normal.

■ Fuel pump

The fuel pump is installed at the bottom of the fuel tank. When working, the fuel is sucked out from the fuel tank and transported to the high-pressure oil pipe after pressurization. When cleaning, installing or replacing the fuel pump, the bolts need to be diagonally fastened. When installing the high-pressure oil pipe, the oil pipe at the outlet should be avoided to twist and bend.

Matters needing attention :

- (1) Make sure there is enough fuel in the tank. Do not allow the fuel pump to run dry without oil or with insufficient fuel. Otherwise, it will cause internal damage of the fuel pump.

(2) When replacing the fuel pump, attention should be paid to preventing foreign dust. When removing the fuel pump, special tools should be used. After removing, fuel should not be allowed to flow everywhere, and should be included in the container. In doing this work, do not fall on the fuel pump, otherwise it will cause internal damage to the fuel pump, should be away from fireworks, and do not approach any source of fire or heat.

■ Throttle body assembly

The throttle body assembly includes a throttle body, a throttle position sensor, an intake temperature and pressure sensor, and an idle speed stepper motor, which are directly operated by the driver, which is called the throttle. The opening of the throttle body determines the amount of air entering the engine, which is measured by the throttle position sensor. Damage to the throttle position sensor will cause the vehicle to fail to operate normally. If the throttle valve controller does not return smoothly, it will cause a serious safety accident and must be repaired immediately.

Matters needing attention:

- (1) It is necessary to install the connector of the throttle bod assembly to avoid damage to the termina.
- (2) Avoid any liquid entering the throttle body to ensure its normal operation.
- (3) It is forbidden that bypass is blocked by dust or small particles, because it will affect idle stability.
- (4) Do not adjust idle screw, because it will affect idle flow.

(5) It is forbidden to remove the throttle position sensor because it will affect the idle voltage of the sensor

(6) It is forbidden to dismantle stepper motor because it will affect idle flow.

■ Injector

The injector is mounted on the intake pipe. Its function is to inject fuel into the engine intake port in time and quantity according to the instructions from ECU. Injector damage can lead to thenormal operation of vehicles.

Matters needing attention:

- (1) It is forbidden to immerse the end of the injector in lubricant, otherwise it will cause blockage of the injection hole.
- (2) It is forbidden to operate empty without oil pressure to prevent damage to internal mechanical components.
- (3) It is forbidden to knock on the injector when the fault occurs in order to avoid damaging the injector.
- (4) When installing the injector, special attention should be paid to the sealing ring not to be cut by the mounting seat.

■ Oxygen sensor

The oxygen sensor is installed on the front end of the exhaust pipe, which is to detect the concentration of oxygen in the exhaust gas and ECU adjusts the fuel injection quantity according to the information in a timely manner to keep the air fuel ratio under the condition of the best. Oxygen sensor failure will lead to high fuel consumption or lack of power, please timely replacement.

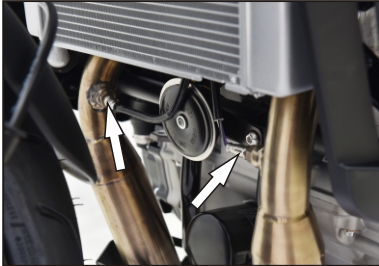

Matters needing attention :

- (1) Oxygen sensor installation needs to be carefully handled, not allowed to fall on the ground, because the oxygen sensor has ceramic inside fragile.
- (2) Wire harness of oxygen sensor should be as far away from exhaust pipe as possible to avoid frictional point and not be stretched mechanically.
- (3) It is forbidden to erase the special high temperature oil type in the screw thread. It is difficult to remove the possible oxygen sensor and muffler which are bonded together.
- (4) Cleaning or lubricating fluids are not allowed to be used at the plug connection of the oxygen sensor. The oxygen sensor may be contaminated if used.

■ Notices for EFI System

- (1) Do not arbitrarily remove any parts of the EFI system or its connectors from its installation position, so as to avoid accidental damage or foreign objects such as water and oil entering the connectors, which will affect the normal operation of the EFI system.
- (2) When replacing or assembling and disassembling any part of the electrical system, you must first turn the key on the electrical door lock to the OFF (closed) position, disconnect the battery wiring before replacing or assembling or disassembling to prevent short circuits or Poor contact causes system damage
- (3) The fuel supply pressure of the EFI system is relatively high, and all fuel lines are made of high-pressure resistant fuel pipes. Even if the engine is not running, high fuel pressure is maintained in the oil circuit. Therefore, be careful not to easily disassemble the fuel pipe during the maintenance process. When the fuel system needs to be repaired, the fuel system should be depressurized before the fuel pipe is removed. The removal and replacement of the fuel pipe should be carried out by professional maintenance personnel in a well-ventilated place.
- (4) When removing the electric fuel pump from the fuel tank, do not energize the fuel pump to avoid electric sparks and fire.

-
- (5) If it is started after refueling for the first time, the fuel line has been removed or the fuel pump has been replaced, there may be air bubbles in the fuel line. Please wait for one minute or repeat the power key switch operation several times until you hear the self-checking pump oil sound gradually diminishing, and you can start normally.
 - (6) After changing the oil pump or draining the oil in the oil pump, you may need to start several more times when restarting. If you still do not see the car after several starts, please check whether the oil pump or the fuel injector is working. If the fuel pump is working properly, please check whether the fuel injector is spraying fuel.
 - (7) Since the adjustment of the idle speed is completely completed by the electronic injection system, no manual adjustment is required. The throttle limit screw of the throttle body has been adjusted when the manufacturer leaves the factory, and the user is not allowed to change its initial position at will.
 - (8) It is strictly forbidden to pull the lead wires of each sensor forcefully to prevent the terminals and wiring from being cracked or broken. When installing, make sure that the sensors are installed in place, otherwise the vehicle will not operate normally.
 - (9) The connectors of the EFI parts of the whole vehicle must be installed in place and the connections are good. The wiring of all connectors is not allowed to be too tight, and a proper margin must be left.
 - (10) It is strictly prohibited to use the method of piercing the skin of the wire to detect the electrical signal input and output of the component.
 - (11) EFI system failures are often related to the circuit. Generally, check the circuit failure first. The most prone fault of the circuit system is poor contact, which is sometimes not when the fault occurs and cannot be locked. Please check the parts that may have poor contact, such as battery wiring, fuse, ignition coil connector and various connectors.
 - (12) Regularly check whether the connections at both ends of the throttle body assembly are tight. If there is any air leakage, if the connection is found to be loose, it must be fastened in time, otherwise the system will become unstable and the vehicle will not be able to drive normally.
 - (13) Regularly check whether the sensor is obviously damaged or damaged. If so, replace with new parts (not repairable); whether the connecting wires are loose or disconnected, whether the wires are frayed or short-circuited or broken, and whether the plugs of the wires are plugged in. If it is in place, whether there is corrosion and oxidation, etc., abnormalities must be eliminated; and when conditions permit, the terminal voltage and resistance values of each sensor can be measured to see if they are within the specified range.

■ Electronic injection system fault code

| The serial number | Fault code | Instructions |
|-------------------|------------|---|
| 1 | P0032 | Cylinder 1 oxygen sensor heater control circuit high |
| 2 | P0031 | Cylinder 1 oxygen sensor heater control circuit low |
| 3 | P0038 | Cylinder 2 oxygen sensor heater control circuit high |
| 4 | P0037 | Cylinder 2 oxygen sensor heater control circuit low |
| 5 | P0132 | Cylinder 1 oxygen sensor circuit high voltage |
| 6 | P0131 | Cylinder 1 oxygen sensor circuit low voltage |
| 7 | P0138 | Cylinder 2 oxygen sensor circuit high voltage |
| 8 | P0137 | Cylinder 2 oxygen sensor circuit low voltage |
| 9 | P0108 | Manifold absolute pressure(sensor)/ atmospheric pressure(sensor)circuit high |
| 10 | P0107 | Manifold absolute pressure(sensor)/ atmospheric pressure(sensor)circuit low |
| 11 | P0118 | Engine coolant temperature (ECT) sensor 1 circuit high |
| 12 | P0117 | Engine coolant temperature (ECT) sensor 1 circuit low |
| 13 | P0113 | Intake air temperature (IAT) sensor circuit high |
| 14 | P0112 | Intake air temperature (IAT) sensor circuit low |
| 15 | P0123 | Throttle / accelerator pedal position sensor / switch a circuit high |
| 16 | P0122 | Throttle / accelerator pedal position sensor / switch a circuit low |
| 17 | P0231 | Fuel pump control circuit high |
| 18 | P0230 | Fuel pump control circuit low |
| 19 | P0262 | Injector A circuit high |

| The serial number | Fault code | Instructions |
|-------------------|------------|--|
| 20 | P0261 | Injector A circuit low |
| 21 | P0265 | Injector B circuit high |
| 22 | P0264 | Injector B circuit low |
| 23 | P0336 | Crankshaft position sensor a circuit range / performance |
| 24 | P0337 | Crankshaft position sensor a circuit low |
| 25 | P2301 | Ignition coil A main control circuit high |
| 26 | P2300 | Ignition coil A main control circuit low |
| 27 | P2304 | Ignition coil B main control circuit high |
| 28 | P2303 | Ignition coil B main control circuit low |
| 29 | P0505 | Idle air control system fault |
| 30 | P0459 | The control circuit of the canister solenoid valve is high |
| 31 | P0458 | The control circuit of canister solenoid valve is low |
| 32 | P0601 | Internal control module memory check error |

NINE、TROUBLESHOOTING

Although we have carried out a comprehensive inspection before motorcycles loading, the possible faults exist in the operation process. The problem of fuel oil, compress or ignition system may result in the power loss and cannot be started.



Troubleshooting table as following provide the quick and easy operating procedures, you can inspect on these important system yourself. However, when motorcycle needs repair, please send the motorcycle to the dealer, their professional technical personnel have the necessary tools and professional knowledge, they can repair the motorcycle better.

NOTICE :

Before troubleshooting, it's better to consult with the dealer. If your motorcycle is still in the guarantee period. Before you are readying to repair, you must be consult your clearer. For it may affect the warrancy content when you disturb the vehicle during the guarantee period.

If the engine refuses to start, perform the following inspections to determine the cause.

- Check the fuel and oil supply in the fuel tank.
- (1) Make sure there is enough fuel in the fuel tank.
- (2) Oil pump is normal work.
- (3) Cut off the oil line from the injector , check the oil inlet to the filter, the filter to the fuel injector between whether there is a gas flow out.

- Check the ignition system for intermittent spark.
 - (1) If sure fuel supply is no problem, ignition system should be checked next.
 - (2) Remove the spark plug and reattach it to the high- tension cable.
 - (3) Fix the spark plug on the body, turn the ignition switch to “  ”position, and after the flameout switch is in “  ”position, press the start button. If the ignition system works normally, blue sparks will be generated between the two poles of the spark plug. If no spark appears, contact the maintenance unit for maintenance.
- Check the engine idle speed.

WARNING :

- Don't make the fuen flow everywhere , any fuel should be collected in a container. No fuel approaches engine and exhaust pipe at high temperature. This check should be performed as far from fire as possible. Meanwhile no fuel approaches fire or heat.
- Don' t fix spark plug close to cylinder head when performing the check, because vaporising fuel in the cylinder may ignited by spark and to cause a fire. To minimize possibility of electric shock, metal part of spark plug casing should atech to bared metal part of motorcycle. To avoid electric shock, a person suffering heart disease or wearing cardiac frequency modulator is forbidden from doing this work.

Troubleshooting example

| Malfunction | | Cause | Remedy |
|--|------------------------------|---|---|
| Engine refuse start | | <ol style="list-style-type: none"> 1.Engine stop switch didn't open 2.No fuel in the fuel tank. 3.Side bracket not raised correctly. 4.Filter clogging 5.Fuel hose was clogged. 6.Spark plug failure. | <ol style="list-style-type: none"> 1.Open the engine stop switch. 2.Fill the fuel oil. 3.Lift the side bracket to the upper limit position. 4.Cleaning filter 5.Replace or clean fuel oil pipe 6.Replace spark plug. |
| Engine hard start or stall easily | Poor sparking or no sparking | <ol style="list-style-type: none"> 1.Dirty spark plug. 2.Defective magneto. 3.Turn off ignition coil. 4.High tension cable leakage. 5.Matter of ignition coil. | <ol style="list-style-type: none"> 1.Clean spark plug and dry it. 2.Maintain magneto or replace. 3.Inspect the circuitry and connect. 4.Replace high tension cable. 5.Replace ignition coil. |
| Ignite the engine but still can not start. | Engine | <ol style="list-style-type: none"> 1.Intake pipe leakage. 2.Wrong ignition timing. 3.The battery is low or no power. 4.Wire port is unconnected. 5.Throttle position sensor fault | <ol style="list-style-type: none"> 1.Check the leakage and change the gasket fastening the bolt 2.Readjust the ignition timing. 3.Battery charging. 4.Check the wiring harness port and connect. 5.View the fault code, check the throttle body position sensor is loose |

| Malfunction | | Cause | Remedy |
|--|---|---|---|
| Ignite the engine but still can not start. | Remove the spark plug , and check the electrode | 1.If the spark plug is wet. | 1.Using dry cloth to wipe, and calibrate the spark plug gap , or replace the spark plugs. |
| | | 2.If the spark plug is dry. | 2.Please ask the dealer to check your motorcycle. |
| Engine run badly. | Poor engine low idling speed. | 1.Wrong valve clearance. 2.Wrong ignition timing 3.In-take tube loose or gasket leak. 4.Weak sparking plug or no sparking. 5.The oil path is in a semi blocking starte. | 1.Adjust valve clearance and check screw of rocker whether damaged or not. change if it be. 2.Readjust the ignition timing 3.Change the in-take tube gasket and fasten screw. 4.Handle it refer to “weak sparking plug or no sparking”. 5.Dredging oil path |
| | Poor performance of engine high-speed. | 1.Wrong ignition timing. 2.Wrong valve clearance. 3.Fuel used up. 4.Oil tube blocking. 5.Wrong valve timing. 6.Valve spring failure. | 1.Readjust the ignition timing. 2.Readjust the valve clearance . 3.Fuel charging. 4.Change the oil tube. 5.Readjust the valve timing. 6.Change the spring. |

| Malfunction | | Cause | Remedy |
|-------------------|--------------------------|--|--|
| Engine noise | Valve noise | 1.Valve clearance is big. 2.Valve wear. | 1.Readjust the valve clearance. 2.Repair or change the valve clearance. |
| | | 1.Piston, valve wear. 2.Cylinder carbon deposit. 3.Piston pin and hole wear. 4.Clutch spring failure. 5.Chain wear. | 1.Change piston, valve (professional staff). 2.Clear the carbon deposit. 3.Replace the piston and piston pin (professional staff). 4. Replace 5. Replace |
| Normal spark plug | Bad cylinder compression | 1.Loose starting arm assembly can not drive the engine. 2.Valve clearance is too small 3.Valve block. 4.Cylinder or piston ring wear. 5.Damaged cylinder head gasket | 1.Retighten the starting arm; change if damaged. 2.Adjust the clearance to 0.04-0.06mm. (cold state) 3.Clean the carbon deposit. (professional staff) 4.Change gasket (professional staff) 5.Replate the senling gasket (professional staff) |

TEN、CLEANING AND STORAGE

Before cleaning and storing the motorcycle, park it on a stable horizontal surface and make sure it is firmly parked. Prepare cleaning tools, such as buckets, soft towels, soft brushes, neutral cleaning agents (designed for motorcycles), etc. Do not increase water pressure or use high-pressure water gun to wash the motorcycle. Do not spray water in sensitive areas, such as EFI system, electrical components, fuel system, exhaust pipe and other components.

When the motorcycle is kept or not used for more than 60 days, the motorcycle should be cleaned first and the storage measures should be taken to avoid damage.

Cleaning

Wait for the engine, muffler, brake and other high temperature components to cool before cleaning.

- (1) Cover the exhaust port of muffler with plastic bag to avoid water.
- (2) Wash the motorcycle thoroughly with low pressure hose of remove loose dirt.
- (3) Mix neutral detergent with water in the barrel. Clean the motorcycle with sponge or soft towel, and use soft brush or bottle washing brush for the position that is not easy to clean. If necessary, use a mild detergent to remove accumulated grease, but do not apply such substances to oil seals, gaskets, drive chains and axles.

- (4) After cleaning, carefully wash the motorcycle with clean water to remove any residue to avoid damage to motorcycle parts.
- (5) After washing, dry the motorcycle with a soft towel or water absorbent towel. When drying, check whether there is any gap and scratch on the motorcycle.
- (6) Start the engine and run at idle speed for a few minutes. Engine heat can help dry wet areas.
- (7) Lubricate the drive chain to prevent rust.
- (8) Lubricate all moving parts and bearing parts.
- (9) To prevent rust, it is recommended to spray a layer of rust inhibitor on all metal surfaces, including chromium plated and nickel plated surfaces.
- (10) Wax the paint surface to prevent corrosion. Rubber parts and plastic parts should be maintained with proper maintenance products.
- (11) Wax the paint surface to prevent corrosion.
- (12) Let the motorcycle dry completely before storage or covering.

NOTICE :

- Do not use a high pressure water gun to flush the vehicle.
- Do not use hard brushes, steel balls or other abrasive cleaning materials to clean aluminum components.
- Do not apply wax to rubber or non lacquer plastic parts.

Storage

Please store the motorcycle in a dry and cool place. If you park the motorcycle outdoors, you should consider using a motorcycle full body cover to block dust.

If you don't ride for a long time, follow these guidelines:

- (1) Clean the entire vehicle thoroughly.
- (2) Run the engine for about five minutes to warm up the oil, then turn off the engine and drain the oil from the engine.
- (3) Add new engine oil.
- (4) Empty the fuel tank (pump or pipe) and drain the remaining oil from the fuel line.

WARNING :

- Gasoline is very easy to burn and will explode under certain conditions. Therefore, please turn off the ignition key before operation. No smoking. Ensure that the operation area is well ventilated and free from any heat and fire sources.
- Engine oil and gasoline are toxic substances. Please handle the used engine oil and gasoline correctly. Keep them out of the reach of children and pay attention to the warning. Otherwise, there is a risk of damage to human health.

- (5) Check the tires and adjust the air pressure. Set up the motorcycle with a support frame or place the front and rear wheels on the main board, so that the two wheels do not touch the ground, and avoid the tire rubber from getting damp.

- (6) Lubricate the drive chain, all control cables, axles, side supports and associated movable fulcrums.
- (7) Wrap the exhaust port of muffler with plastic bag to avoid moisture.
- (8) If kept in a humid or salty place, please apply a thin layer of oil on all metal surfaces to prevent rust. And pay attention not to make motorcycle rubber parts and cushion coated with oil, so as to avoid aging.
- (9) Remove the battery and store it in a place without direct sunlight, humidity and temperature not lower than zero. The battery should be charged once a month during storage. Keep the battery fully charged, especially in cold weather.
- (10) Put on the dust cover to prevent the accumulation of dust and dirt.

NOTICE :

- Please store the motorcycle in a dry and ventilated place. If you often wash your motorcycle in the garage and park it in it, the garage will get very wet. High humidity will increase corrosion. If the air is not circulating, even in the high temperature environment , the wet motorcycle will rust.
- Please make the necessary repairs before storing the motorcycle.

ELEVEN、 TECHNICAL SPECIFICATION

| Carload parameter | |
|--------------------------|---------------------------|
| Overall length | 2020mm |
| Overall width | 780mm |
| Overall height | 1330mm |
| Wheelbase | 1390mm |
| Minimum ground clearance | 150mm |
| Unloading weight | 194kg |
| Max loading capacity | 180kg |
| Max. speed | 138km/h |
| Max. accelerated noise | ≤77dB (A) |
| Climbing ability | ≥20° |
| Starting performance | ≤15s |
| Wheel and brake | |
| Front shock-absorber | Hydraulically telescoping |
| Rear shock-absorber | Spring oil resistance |
| Turn angle | left/right≤48° |
| Front tire type | 110/70-17 54H |
| Rear tire type | 150/60-17 66H |
| Front tire pressure | 280kPa |
| Rear tire pressure | 280kPa |
| Tire rim (front/rear) | Light alloy/Light alloy |
| Front rim type | MT3.0×17 |
| Rear rim type | MT4.0×17 |
| Front brake | Disk brake |
| Rear brake | Disk brake |
| Brake fluid | DOT 4 |

| Engine | |
|----------------------------|-----------------------------|
| Model | Liquid cooling, four stroke |
| Cylinder | Two |
| Bore×stroke | 68.0mm×55.2mm |
| Displacement | 400.9ml |
| Comprssion ratio | 11.6 : 1 |
| Spark plug | JH9RC |
| Standard power | 31.5kw/9500 (r/min) |
| Max torque | 34N·m/8000 (r/min) |
| Ldling speed | 1400±140 (r/min) |
| Ignition method | ECU electron ignition |
| Lubricant method | Pressure splash lubrication |
| Lubricant | SAE10W-40/SJ |
| ECU model | MT05 |
| Transmission system | |
| Clutch | wet type multi-plate |
| Transmission gear ratio | six-gear international |
| Primary reduction ration | 3.087 |
| Final reduction ration | 2.923 |
| One gear | 2.333 |
| Two gear | 1.529 |
| Three gear | 1.182 |
| Four gear | 1.043 |
| Five gear | 0.909 |
| Six gear | 0.807 |

| Electric system | | |
|---------------------------------|---|--------------------------------------|
| Start method | | Electrical start |
| Front light | Driving beam | 12V 30W |
| | Passing beam | 12V 16W |
| | Front position light | 12V 2.3W |
| | Daytime running lamp | 12V 4W |
| Tail light/barke lamp | | 12V 1.5W/3.2W |
| Rear registration plate lamp | | 12V 5W |
| Turn signal lamp(signal) | | 12V 2W |
| Horn | | 12V 3A |
| Battery | | 12V 10Ah |
| Fuse | Vehicle circuit | 30A |
| | EFI system | 15A |
| | ABS hydraulic control unit motor | 25A |
| | ABS hydraulic control unit solenoid valve | 15A |
| | Activate the ABS | 5A |
| | Vehicle lighting fixtures | 10A |
| Fuel system and capacity | | |
| Fuel | | Only use unleaded gasoline qualified |
| Capacity of fuel | | 15. 5L |
| Fuel pump | The rated voltage | 12V |
| | Working pressure | 350kPa |
| | Flow | ≥30L/H |
| | Electric current | ≤1.8 A |
| Engine oil | Replace oil only | 2500ml |
| | Replace oil and oil filter | 2700ml |
| | Total oil capacity | 3000ml |
| Coolant | | 1300ml |

CK ALIEN 400

**All pictures and information are only for reference,
please set the reality motorcycle and specifications as real one without notice.**