



Maintenance Manual

YG50Q-8



Chongqing YINGANG technology group co., LTD

Foreword

This maintenance manual is only for the use of YINGANG repair shop. This manual is not available for all knowledge about motorcycles, only for maintenance and maintenance of YG50Q-8. The aim is to understand maintenance principles, maintenance procedures and maintenance skills. Failure to understand the knowledge will result in improper or dangerous situations in assembly and maintenance.

This information is for maintenance and maintenance of YG50Q-8 reference. If the product has any modification or change, the distributor will be informed in advance and the content of the change will be reprinted.















Note:

Specifications and designs are subject to minor changes without prior notice.

Symbol description:

 **Warning:**

Some procedures must be complied with to avoid injury to myself, others or locomotives, which can lead to death. For some programs, it's easier to understand the second one

1 	2 	3 
4 	5 	6 
7 	8 	9 
10 	11 	12 
13 	14 	

- 1、 Type of special tools
- 2、 torque wrench
- 3、 Add a liquid
- 4、 Wear limit or limit
- 5、 Engine speed
- 6、 Resistance, voltage, current
- 7、 engine oil
- 8、 gear oil
- 9、 molybdenum sulfide
- 10、 bearing grease
- 11、 lithium lubricating grease

12、 Molybdenum lubricant 13、 thread sealant 14、 new parts

Contents

Chapter 1 overview	1
1.1 Overview	1
1.2 Lubrication system	13
1.3 Inspection and adjustmen	24
Chapter 2 Engine	40
2.1 Fuel system	40
2.2 Removal and installation of engine	46
2.3 Cylinder head, cylinder and piston	51
2.4 Clutch and Right crankcase cover	68
2.5 Magneto and starting system	79
2.6 Crankcase, crankshaft and Shift mechanism	88
Chapter 3 Vehicle body	105
3.1 Frame and exhaust system	105
3.2 Front wheel, front overhang and steering stem	110
3.3 Rear wheel and rear overhang	122
Chapter 4 Electrical system	128
4.1 General remarks of electrical system	128
4.2 Power supply system	129
4.3 Starting system	132
4.4 Illumination signal system	135
4.5 Electrical starting control system	141
4.6 Engine management system	145
4.7 Electrical System Diagram	157

1、 Overview

Engine Number Position

Bar Tool

About Motorcycle Maintenance

Maintenance Period Table

Technical Data of Main Performance

Symbol Descriptions

Standard Torque Values

Engine Number Position

Photo of Complete Vehicle:



Frame Number Position:

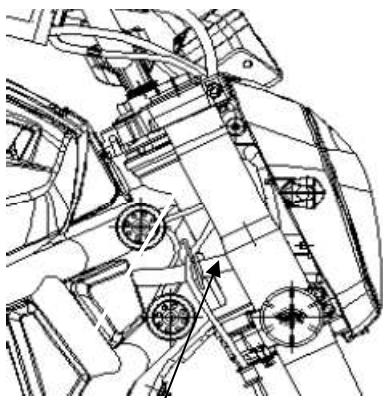

Frame Number

Engine Number Position:

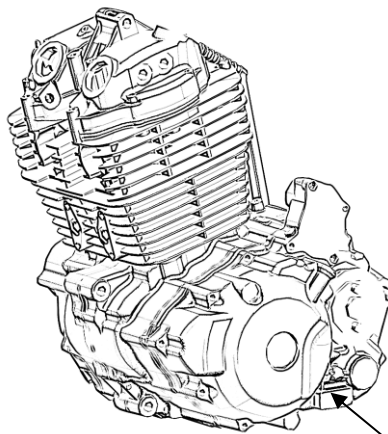

Engine Number

Maintenance Precautions

1. Whenever reassembling after being disassembled, replace new washers, sealing members, etc.

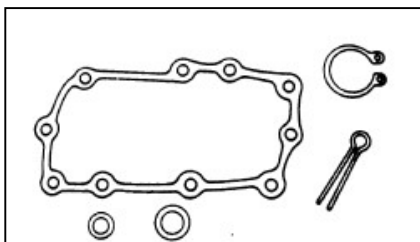

2. While fastening bolts or nuts, proceed in diagonal crossing sequence to gradually screw down to the required torque for 2 to 3 tries.

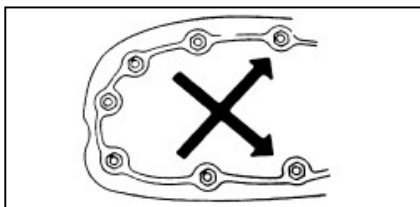

3. After being disassembled, the parts and components should be cleaned before being inspected and measured



To clean the spare parts, use only the cleaning fluid that is incombustible or has high ignition point.

Before reassembling, apply the specified lubricating oil to the sliding surface of the parts and components.

After reassembling, check whether all the spare parts are mounted properly by means of turning, moving and operating them.

4. To disassemble and assemble a motorcycle, special service tools (SST) and general-purpose tools must be used in accordance with relevant regulations.

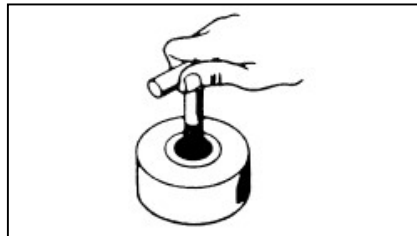

5. The specified or equivalent lubricating grease (oil) must be applied to or refilled into the specified locations.

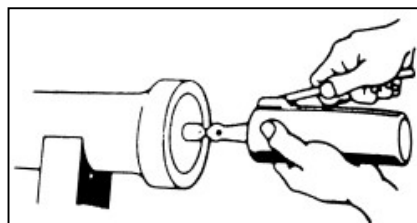

6. When 2 or more persons are carrying out the operation, they shall work with each other and pay attention to safety.

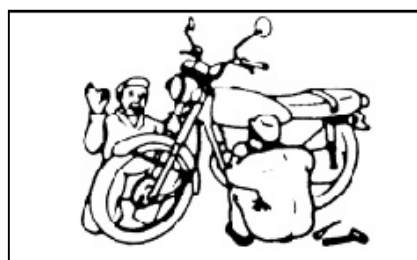

7. Before operating, always remove the negative (-) end of the battery first and take care to prevent the wrench or the like from touching the frame. After operating, reconfirm all the connections, fixings and junctions. If the battery is already removed, connect the positive (+) end first.

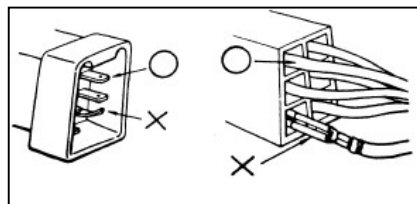
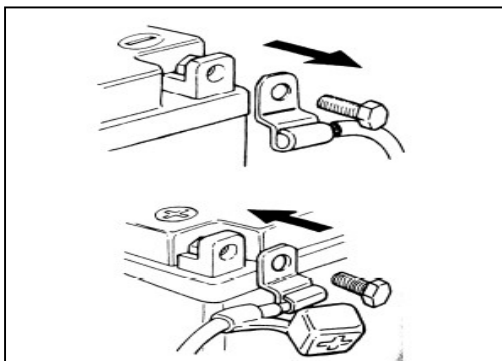

The connector shall be fully inserted in place.

For a connector with lock, confirm whether the lock is completely fixed.

Make sure the harness is not falling off

Make sure the plastic jacket of the connector is securely covering the connector without scaling off.

- In case the fuse is blown, check for the causes and, after being repaired, replace corresponding fuse as per the specified capacity.

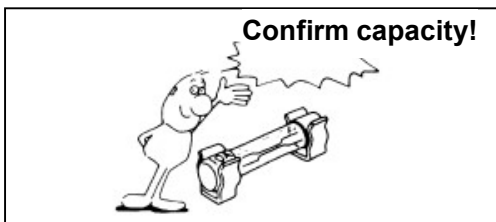

- The caps must be securely put on the terminals after the operation is complete

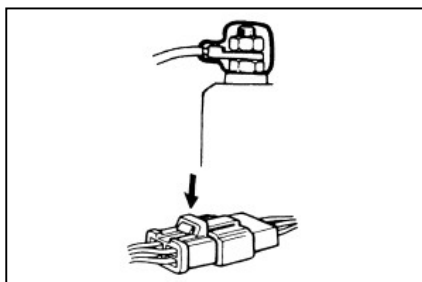
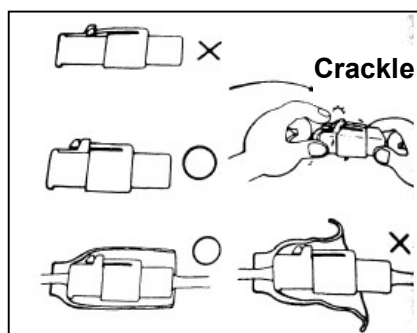

- Before connecting a connector, make sure the sleeve is not broken and the opening of the intermediate terminal is not too large

The joint shall be fully inserted in place.

Make sure the plastic jacket is housing the terminal completely. The opening of the plastic jacket shall not face up.

- While disassembling a connector joints with lock, release the lock before proceeding with operation.

While disassembling a connector joints, hold the connector body without pulling the wire harness.

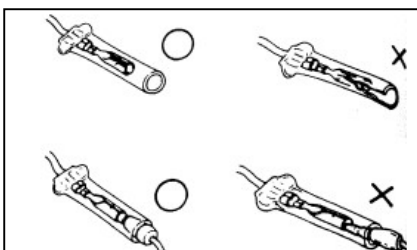

Before connecting the connector, the terminals shall be free from breaking or bending. Make sure the terminals are not too long or are falling off.

- The harness fixing strap shall firmly button the specified position on the frame.

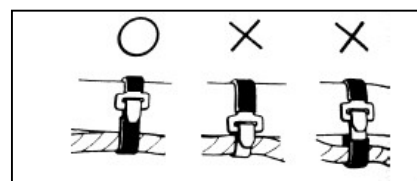

13. The clamp shall reliably bite the wire harness

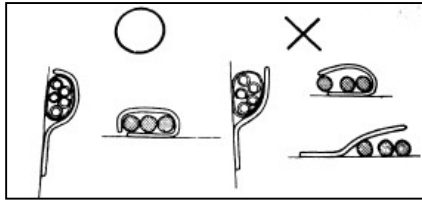

In case of a welded clamp, it shall not bite the wire harness towards the weld mark

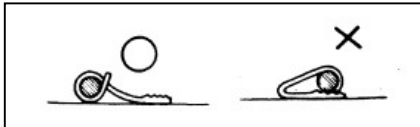

The wire harness shall be clamped at the position without contacting a rotating part or a removing element.

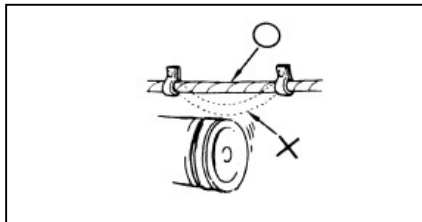

The wire harness shall be clamped at the position without contacting a part that generates high temperature.



The wire harness shall be clamped at the position without contacting the edge or sharp corners of the vehicle body.

The wire harness shall be incapable of passing through the position contacting a bolt, a screw head or any front part.

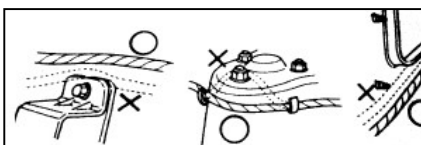

The wire harness shall not be slackened or be forcibly pulled.

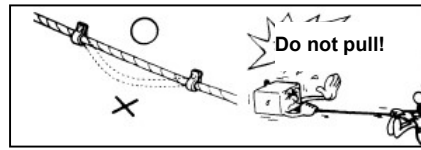

If the wire harness has to contact the edge or sharp corner parts, the contacting part shall be protected with hose or adhesive tape.

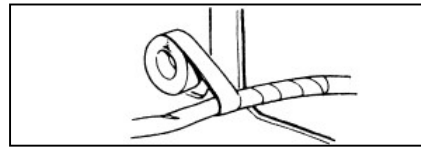

In case of a wire harness with garland, it shall be reliably harnessed.

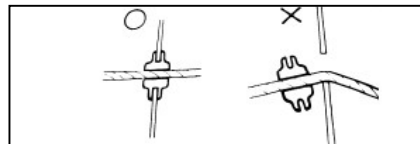

Do not damage the garnish of the wire harness.

Once the wire harness is damaged, repair it by coiling with plastic adhesive tape.

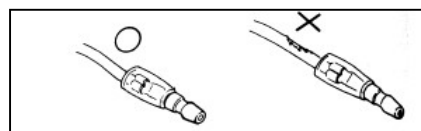

While mounting parts and components, do not press the wire harness.

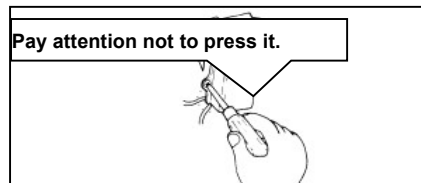

Do not mount wire harness with it twisted.

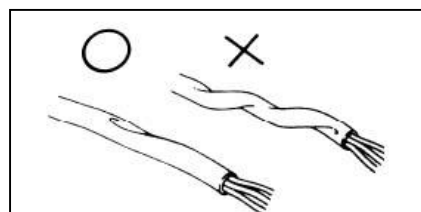

14. When wiring, note when turning it leftwards or rightwards to the limit position, the wire harness shall not be tightened up or slackened, and make sure there is no significant bending, pressing, intervening of marginal parts.

cause of bad operation and damage.

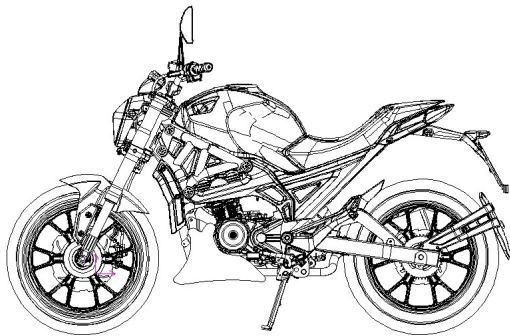
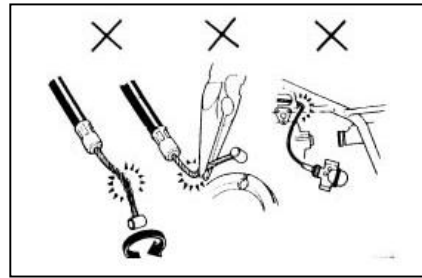

15. While using the test table, operate according to the maintenance manual after understanding the explanations in the instruction manual.
16. Do not drop or throw the parts and components.

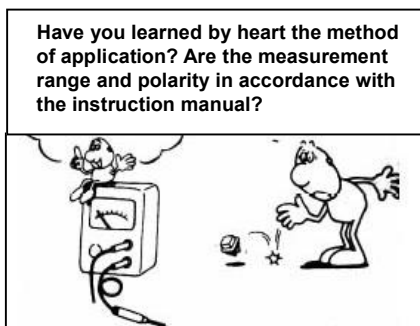

17. In case of rust on the terminals, carry out connection operation after disposing it with abrasive paper, etc.



18. Do not forcibly twist or forcefully bend the cable.
Because a deformed or damaged cable is the

Technical Data of Main Performance

	Item	Data
Dimension & Weight	Length	1990mm
	Width	840mm
	Height	1070mm
	Wheelbase	1340mm
	Min. ground clearance	180mm
	Curb weight	132kg
Vehicle body	Frame type	diamond frame
	Rake angle	25.5°
	Front suspension device	spring & hydraulic composite damping
	Rear suspension device	spring & hydraulic composite damping
	Front Tire size	110/70-17
	Rear Tire size	130/70-17
	Front wheel pressure	Normally loaded: 280 kPa,
	Rear wheel pressure	Normally loaded: 280 kPa,
	Front brake	Single disc type Model Φ 265
	Rear brake	Single disc type Model Φ 220
	Fuel tank volume	12L
	Fuel grade	92#
Engine	Mode	Single-cylinder force air –cooling 5-stroke engine
	Cylinder bore × Stroke	40mm × 39.6mm
	Cylinder displacement	50cc
	Compression ratio	10:1
	Max. power	3.2kw/10000rpm
	Max. torque	3.7N.m/8500rpm
	Valve clearance (cold)	IN: 0.13-0.20 EX: 0.20-0.30
	Valve driving gear	Chain drive
	Air filter	Paprt cartridge
	Cooling method	Air cooling
	Lubrication method	Please apply Shell 10W/40-SF engine oil in summer and 10W/30-SF in
	Engine oil grade	winte
	Engine oil charge volume	1.6L
	Engine oil filter element	Foam filter
	Electric motor starting	Electric start
	Idle speed	1400±100r/min
Net weight of engine	24±1kg	

Driving system	Clutch	Wet clutch, coil clutch, paper friction wafer
	Clutch operating system	Manual mechanical
	Variable speed gear	5-speed constant mesh
	Primary reduction ratio	4.438
	Transmission gear ratio	I 2.692 II 1.824 III 1.4 IV 1.130 V 0.960
	Final reduction ratio	4.000
	Gear shifting mode	Left foot operated to and back type Sequence: I—N—II—III—IV—V
	Electrical system	Electric generator
Accumulator capacity		12V7A.h
Power supply system		DC power supply, and the electric generator is only used to recharge the accumulator
Fusible cutout		15A/10A
Spark plug		CPR8EA
Spark plug gap		0.6-0.7mm
Ignition coil type		Open magnetic circuit
Fuel supply mode		Electronically injection, ECU control
Ignition mode		EMS
Ignition advance angle		EMS
Ignition timing		EMS
Front lamp		12V/35W/35W
Turn lamp		Front: 12V10W Rear: 12V10W
Stop / Rear-position lamp		12V21W/5W

Standard Torque Values

ENGINE

Item	Quantity	Thread diameter (mm)	Torque value (N.m)	Thread locker
Cylinder head cover connecting bolt	13	8	8~12	
Cylinder bolt	4	10	40~50	
Valve adjusting screw nut	2	6	8~12	
Timing driven sprocket bolt	4	10	8~12	
Rocker-arm shaft cover	2	7	7~11	
Magneto flywheel fastening nut	2	14	24~28	
Clutch fastening nut	1	12	38~45	LOCTITE 243
Primary driving gear fastening nut	1	18	114~126	LOCTITE 243
Oil drain plug	1	18	143~157	LOCTITE 243
Crankshaft, main-shaft bearing baffle screw	1	12	28~32	
Stud	5	6	8~12	LOCTITE 648
Stud	1	6	8~12	
Exhaust valve stud bolt	4	10	40~50	
Stator connecting bolt	2	8	10~14	LOCTITE 243
Stator leads pressure plate bolt	3	6	8~12	LOCTITE 648
Spark Plug	2	6	8~12	LOCTITE 648
Pensioner plate fastening bolt	1	12	18~25	
	1	6	7~10	





Vehicle body



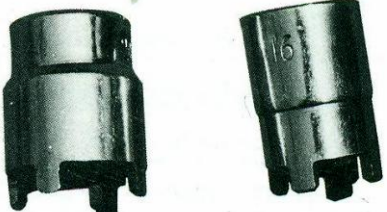

Item	Quantity	Thread diameter (mm)	Torque value (N.m)	Thread locker
Front wheel spindle	1	14	50~60	
Front vibration damper plate	1	10	30~40	
Rear wheel spindle nut	1	16	60~90	
Rear fork shaft nut	1	14	50~60	
Engine hanging bolt	3	10	30~40	
Steering handle set bolt	4	8	20~30	
Front fork vertical pipe cap nut	4	8	20~30	
Lower connection plate set bolt	1	22	60~90	
Upper connection plate set bolt	2	10	30~40	
Rear sprocket nut	2	6	8~12	
Brake disc fastening nut	6	8	20~30	LOCTITE 243
Speed signal panel screw	8	8	20~30	LOCTITE 243
Front brake caliper screw	4	8	20~30	LOCTITE 243
	2	8	20~30	LOCTITE 243

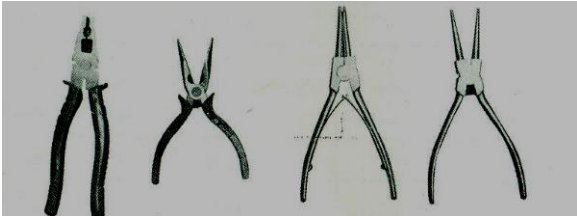
In addition to the torque values of the important parts as listed above, the torque values for other standard fasteners are as follow:

Name and dimensions	Torque value (N.m)
5mm bolt & nut	4.5 ~6
6mm bolt & nut	8 ~12
8mm bolt & nut	18 ~25
10mm bolt & nut	30 ~40
12mm bolt & nut	50 ~60
5mm Screw	3.5 ~5
6mm Screw	7 ~11
6mm spool bolt & nut	10 ~14
8mm spool bolt & nut	20 ~30
10mm spool bolt & nut	30 ~40

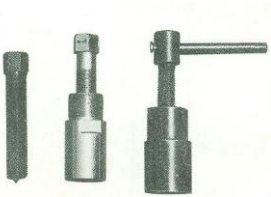
Bar Tool

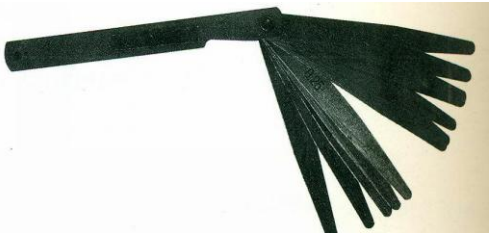
	
<p>Motorized gun: special power tool for mantling/dismantling bolt and nut</p>	<p>Pawl socket: for mantling/dismantling oil filtering element nut and clutch nut</p>
	
<p>A and B bolt socket: for mantling/dismantling A and B bolt and exhaust muffler bolt Adaptor: electric special tool for cross,hexagon gun tip Valve adjusting socket: for valve clearance adjustment</p>	<p>Socket: for mantling/dismantling nuts and bolts</p>
	
<p>Cutting plier, Nipper plier, expansion plier: for mantling/dismantling flexible retainer</p>	<p>T-socket wrench</p>

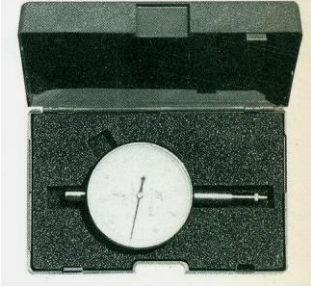
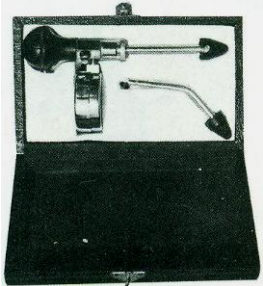
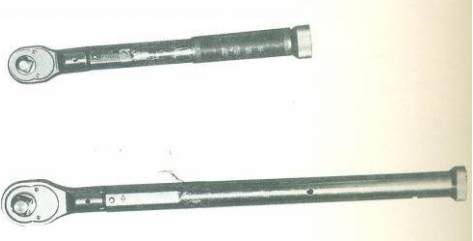
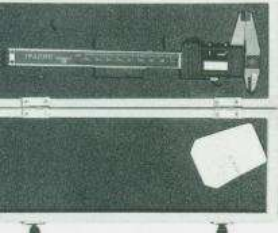
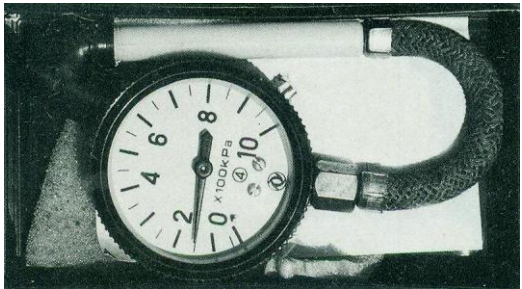
	
<p>Magnetic generator rotor puller: for dismantling magnetic generator rotor</p>	<p>Rubber hanner, Iron hammer, Copper hammer</p>
	
<p>Feeler gauge: to measure the clearance of piston, cylinder, valve, etc.</p>	<p>Micrometer: to measure the dimensions of piston, piston pin, etc.</p>
	
<p>Dial gauge: to measure the wheel bouncing, cylinder inner diameter, etc.</p>	<p>Cylinder barometer: to measure the cylinder pressure</p>
	
<p>Wrench: measure tightness of ad bolt</p>	<p>Vernia caliper: measure size of rear wheel hub internal diameter</p>
	
<p>Tire barometer: to measure the tire pressure</p>	

Maintenance Period Table

Maintenance times Maintenance Items	Period	Odometer km (Remark 2)				
		1000 k m	4,000 km	8,000 km	12,000 km	Remarks
* Fuel system passage			I	I	I	
* Throttle operating system		I	I	I	I	
* Throttle valve body		I	I	I	I	
Air filter element	Remark 1		C	C	Replace every 12,000km driving	
Spark Plug			I	I	Replace every 12000km driving	
Engine lubricant oil		For a motorcycle, change every 1000km, and then change it every 2000km driving				
Oil filter		R	Replace every 12,000km driving			
* Tensioner	Remark 3	I	I	I	I	
both intake and exhaust	Remark 3	I	Check every 4,000km driving			
Clutch		I	I	I	I	
* Driving chain		Proceed with I and L for every 500km driving				
** Front and rear brake system		I	I	I	I	
** Brake Pad		I	I	I	I	
** Brake fluid		Change every 2 years				
* Front and rear brake lamp switch		I	I	I	I	
* Accumulator	Monthly	I	I	I	I	
* Suspension system		I	I	I	I	
* Nut and bolt fastening		I	I	I	I	
** Wheel & tire		I	I	I	I	
** Steering column bearing		I	I	I	I	
** Steering backstay cable	Inspect every 5000km driving and replace every 10000km driving					

Maintenance shall be carried out to the motorcycle in a specified period. The meanings of various symbols in the list are as follows: I: Carry out inspection, cleaning, adjustment, lubrication or replacement.

C: Cleaning. **R:** Replacement. **A:** Adjustment. **L:** Lubrication.

* This item is subject to maintenance by persons from YINGANG TECHNOLOGY Service Station. If the user has special service tools, maintenance accessories or maintenance ability, it can repair it by itself.















** To ensure safety, this item is only subject to maintenance by persons from YINGANG TECHNOLOGY Service Station.

Remarks:

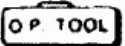
- ① While driving in a dusty area, it shall be cleaned more often.
- ② When the odometer reads more than the given maximum value, its maintenance period shall still repeat as per the mile interval as stipulated in the table.
- ③ To ensure safety, the adjustment of timing chain and valve clearance shall only be carried out by persons from YINGANG TECHNOLOGY Service Station.

Symbol Descriptions

Meanings of various symbols in this manual:

1		 Explanation Measures to be prompted during operating, inspecting and maintaining.
2		 NOTICE: Special instructions or disposal measures given to prevent motorcycle from being damaged.
3		 WARNING: Special instructions or measures given to avoid serious damages or personal injuries.
	Each time reassembled after being removed and disassembled, it must be replaced with a new one.	
	Use special service tools (SST)	
	Use general-purpose tools.	
	Tightening torque of 50 N.m.	
	Use suggested engine oil.	
	Use the mixtures of engine oil and molybdenum disulfide	
	Use thread locker.	
	Use sealant.	
	Use lithium base grease.	

2、Lubrication system

Maintenance notice	Inspection of lubricating oil
Troubleshooting	Replacement of lubricating oil
Lubricating Position of Complete Vehicle	Cleaning of Lubricating Oil Strainer
Lubrication of Control Lines	Cleaning and Replacement of Lubricating Oil Filter
Engine Lubrication System Diagram	Oil Pump

Maintenance notice

This section introduces the inspection and replacement method of engine lubricating oil as well as the cleaning method of lubricating oil strainer and lubricating oil filter. It also introduces various lubricating positions of the complete vehicle of this model.

As an important factor that influences the engine's performance and life span, the lubricating oil must be selected as per regulations; ordinary engine oil, gear oil, vegetable oil, etc. are not allowed to be used instead of it. This engine was filled with gasoline engine oil of 10W/40EG grade when leaving factory for sale. If you want to use other lubricating oil, its quality scale must reach Grade SG, and its viscosity shall be selected according to the accompanying diagram depending upon region and air temperature changes. While replacing lubricating oil, fully discharge the original lubricating oil in the crankcase and clean it up with washing kerosene, and then refill fresh lubricating oil as per regulations.

The lubricating oil inside the engine must be fully discharged before inspection and cleaning.

Technical specifications: Lubricating oil charge volume: 1L

Oil pump flow rate: 8L/min (when engine speed is at 4000 rpm).

Tightening torque of oil drain plug:28-32N.m

Selecting viscosity as per temperature conditions

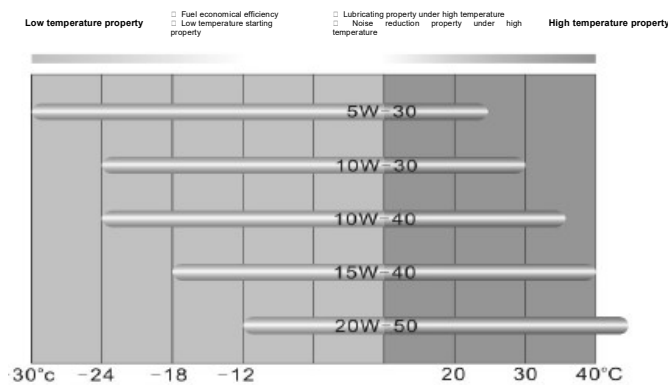

WARNING:

Repeatedly contacting the engine lubricating oil for a long period may cause skin cancer.

Although such possibility is small when you deal with used engines oil every day, Care must be taken to fully cleanse your hands with soap and water after dealing with the used engine oil. Children are strictly prohibited from getting near to it.

Troubleshooting

● Lubricating oil contaminated

1. Fail to replace lubricating oil according to the maintenance period table;
2. The pouring orifice thread is damaged thus causing poor seal;
3. The piston ring is worn.

● Lubricating oil pressure low

1. The oil level is too low;
2. Oil through, orifice port or oil strainer is clogged;
3. Oil pumps failure.

● Lubricating oil consumes too fast

1. There is leakage with the engine;
2. The piston ring is worn.
3. The inlet/exhaust valve guide is worn;
4. The oil shield is worn or damaged.

Lubricating Position of Complete Vehicle

Upper/lower retainers of vertical pipe



Among the positions shown in the above diagram, besides applying dedicated lubricating oil for chain  to the driving chain, apply lithium base grease to all other positions.

All lubricating oils not specified for use in this manual shall be ordinary common lubricating oil.

All sliding surfaces and cables not shown in this diagram shall be coated with lubricating oil or lubricating grease.

Lubrication of Control Lines

Regular lubrication shall be carried out to the clutch control line, throttle control line and steering cable. To do this, remove the upper joining parts of all control lines, sufficiently lubricate and maintain their hoisting cables and all points of support with lithium base grease.

Engine Lubrication System Diagram

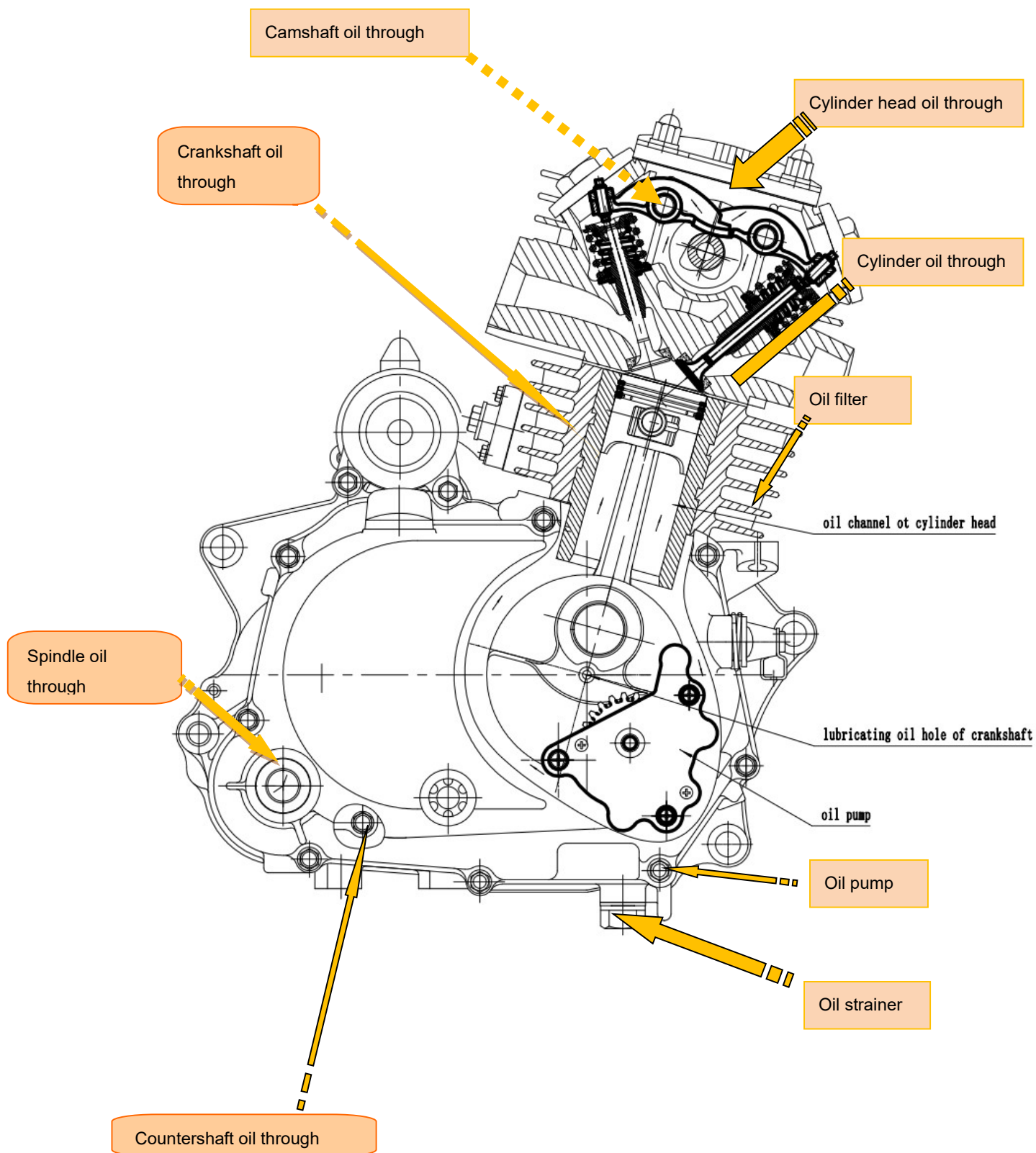

Left crankcase body oil through

Cylinder block, cylinder head, camshaft bearing seat and a camshaft oil through

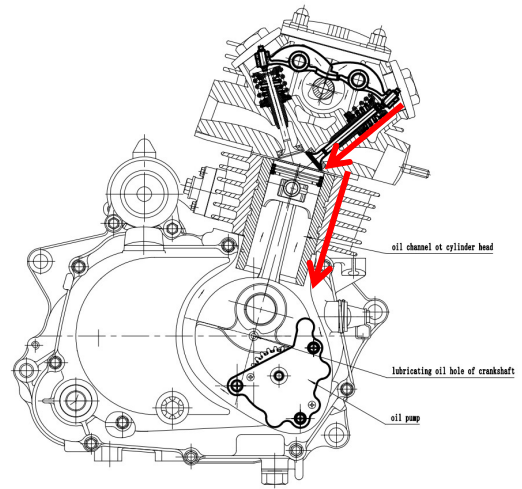

Replacement of lubricating oil

While replacing lubricating oil, it shall be carried out before the engine has cooled down. This will ensure quick and complete discharge of the engine oil inside the crankcase.

When replacing, unscrew the oil drain plug and discharge the waste engine oil, and then clean the oil drain plug, engine oil strainer, engine oil filter, etc. Finally, insert the oil drain plug. Unscrew the oil filter plug and slowly refill 1.8L new engine oil of the specified trademark into the crankcase, then insert the oil filter plug.

Lubricating oil draining



Waste engine oil flow into the oil collector

⚠ CAUTION

Application of engine oil of poor quality will have an impact on the functional performance and life span of the motorcycle engine.

Cleaning of Lubricating Oil Strainer

It shall be carried out while replacing lubricating oil.

While cleaning, you should unscrew the oil drain plug to drain the waste engine oil, and flush the strainer with cleaning agent; place the motorcycle side down to facilitate cleaning as required. Then insert the oil drain plug, and proceed with the remaining steps according to the method of "Replacement of Lubricating Oil".

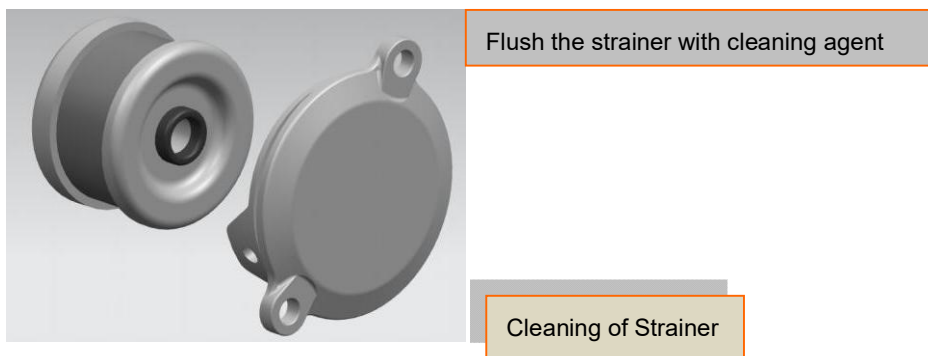

Cleaning and Replacement of Lubricating Oil Filter

Remove the engine oil filter cover to detach the engine oil filter element, clean the filter cover and filter element with cleaning agent, and then mount the clean engine oil element. Replace with a new one as required.

Check for damage of the engine oil filter cover and its O-shaped sealing ring; replace with a new one as required.

Mount the engine oil filter cover and screw up the bolt to the specified torque.

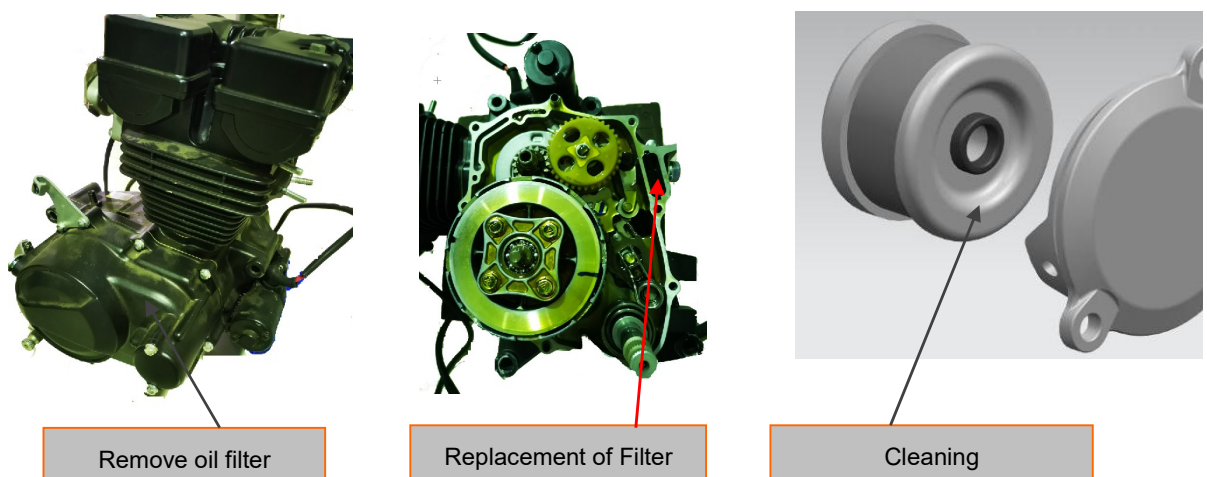

⚠ Notice

Before the crankcase is refilled with fresh engine oil, the engine oil filter must be cleaned.

Oil Pump

In case of failure, the oil pump needs to be removed for repair or replacement.

This section includes the following contents:

Steps and illustration for oil pump removal;

Steps and illustration for oil pump installation;

Disassembly and assembly of oil pump, etc.

Steps for oil pump removal:

1. Remove the oil drain plug to drain the engine oil

inside the crankcase.

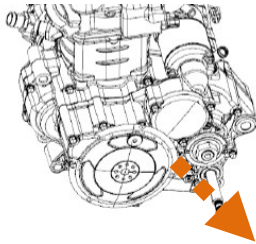

2. Loosen the right crankcase cover connecting bolts to detach the right crankcase cover components.

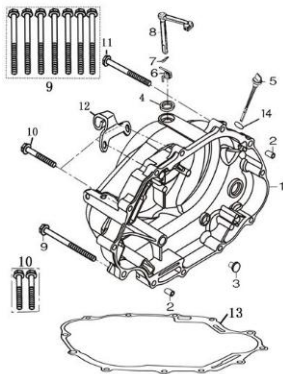

3. Use the clutch push rod extractor **S TOOL** to remove the clutch push rod assembly; use the fixing tool **S TOOL** to prevent the clutch and the primary driving gear from rotating; loosen the nut to remove the clutch component,

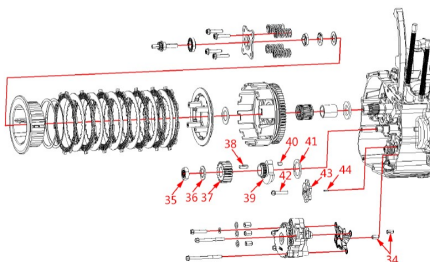

4. Remove the oil pump.

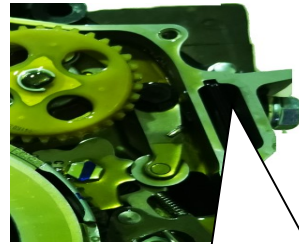

Remove the oil pump

Steps for oil pump installation:

The installation procedures are the removal procedures in reverse order. Pay attention to the following points during the installation:

- 1、 The spare parts shall be clean and intact;
- 2、 Install clutch assembly, and the retaining nut M18 shall be coated with thread retaining adhesive LOCTITE243; tightening torque: 108N.m -123N.m;
- 3、 Install clutch push rod assembly;
- 4、 After the right crankcase cover is mounted in place, the angle and position of the clutch operating lever may possibly change; readjustment shall be carried out to accommodate the adjustment of clutch control line;
- 5、 The seal washer at the bolt under the oil pump, shall be replaced with new ones.;
- 6、 Remember to refill engine oil after all these are completed. .

⚠ CAUTION

The clutch retaining nut must be screwed up to the specified tightening torque, must be applied to prevent the nut from getting loose.

Disassembly and assembly of oil pump

Disassemble and assemble oil pump according to the following diagram.

While assembling, the rotor shall be coated with engine oil.

While assembling, check the clearances between the inner and outer rotors of the oil pump; replace it if it exceeds the wearing limit.

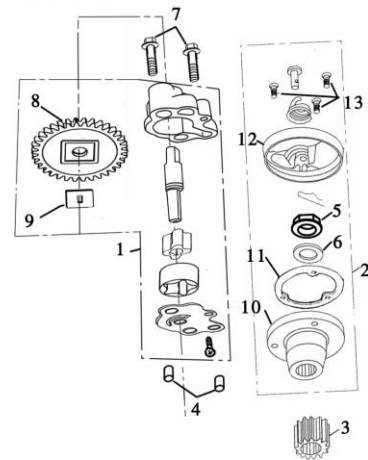

No.	Procedures	Quantity	NOTICE
	Removing order		Installation is in the reverse order of removal
1	Oil pump location pin	2	
2	Oil pump sealing paper gasket	1	Replace it with a new one while assembling
3	Oil pump assembly	1	Coat it with engine oil; replace it when exceeding the wearing limit
4	Flange bolts M6*30	1	
5	Flange bolts M6*60	1	
6	Flange bolts M6*75	1	
7	Oil pump rubber ring	3	

3、 Inspection and adjustment

Maintenance notice	Brake system
Spark plug	Running system
Lubricating oil	Clutch control line
Oil output tank	Driving chain
Timing phase	Battery Checking
Cylinder pressure	Replacement of Fuse
Timing chain tension	Brake lamp adjustment
Valve clearance	Headlamp dimming
Air filter	Steering stem bearing
Idle speed	Suspension system
Throttle control	Bolts, nuts and fasteners

Maintenance notice

The parts that are washed should proceed thru relevant examination work. The purpose is to confirm that the part whether it needs repair or replace. The examination method is divided into three methods include direct examination, testing examination and detecting examination

Direct examination method

This method does not need instrument and other tools, it checks and determines the technologic state of part just according to the sense organs of human being. The way is simple and easy to use, it is used wide in motorcycle maintenance.

Testing examination method

This way is a way that test the size of part and change of geometric form with gauge and instrument, and make contrast to the allowed limit with the data to confirm the technologic state of part. The accuracy of this way is high, but before test should check the precision of gauge and instrument carefully and choose the testing position reasonably.

Detecting examination method

This way can test the invisible flaws of part. In motorcycle maintenance, generally adopt the best easy way--dipping oil to beat by hammer, that means putting the parts into coal oil or diesel oil to soak several minutes then take out and wipe the surface, spread talcum powder on the surface of parts uniformly, beat its nonworking sue face lightly by small hammer. owing to beating will cause versatility of part, if part has crack, then the oil sludge that dipped into crack originally will splash due to beating and versatility, then the talcum powder on surface will be dyed yellow, so one

yellow line will be revealed at the crack point.

Explanation:

Unless expressly stated or indicated in the maintenance period table, check and adjust all parts of the YG125-30A motorcycle according to the contents hereof before using it.

Technical specifications

- Throttle bar free stroke: 1-3mm
- Recommended spark plug: CPR8EA
- Spark plug gap: 0.7-0.9mm
- Valve clearance (cold)
 - IN) 0.13-0.20mm
 - EX) 0.20-0.30mm
- Idle speed: 1400±100 (rpm)
- Cylinder pressure: ≥ 1.3 MPa(1500rpm)
- Driving chain tension: 10~20mm
- Rear brake pedal free stroke 20~30mm
- Front brake operating handle free stroke 10~20mm
- Clutch operating handle free stroke 10~20mm

Spark Plug

Remove the spark plug cap. Remove the spark plug with a socket wrench. Visually check whether there is any damage with the spark plug insulator and ablation with the electrodes. If yes, replace them.

Check the spark plug electrode gap with a plug gauge.

Spark plug electrode gap 0.7 -0.9mm. Carefully adjust the electrode gap. Then clear away the accumulated carbon and contaminants with a spark plug cleaner or string wire.

Check that the spark plug sealing gasket is in good condition.

To mount the spark plug, manually screw up the spark plug first, and then tighten it with a socket wrench. Put on the spark plug cap.

Gap a: 0.7-0.9mm

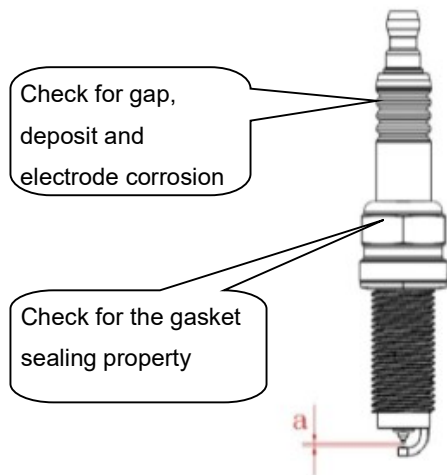

Lubricating oil

⚠️ Park the motorcycle on a flat surface, let the engine stop for 2-3 minutes, and check to see whether the oil level is in between the upper and lower line the oil gauge. if the engine oil level is under the lower scale line, refill the recommended lubricating oil until the oil level reaches the upper-middle limit.

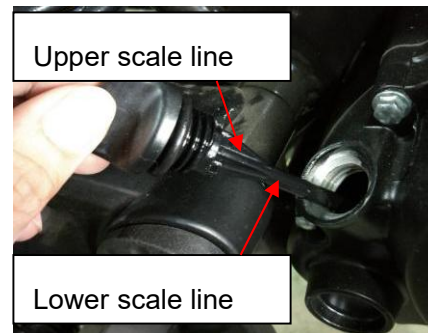

⚠️ Notice

The insufficiency or poor quality of the engine oil will lead to the premature wear-out of the engine

Timing phase

It shall be carried out when the vehicle is new or there is any question about the timing phase.

Remove the cylinder head cover

Turn the crankshaft pulley Counterclockwise to align the scale line "I" with the indication mark "▼" on the front-left cover.

When the piston is at the upper dead point, the scale line on the camshaft is at the same level with the.

Notice

At this point, the piston must be at the upper dead point of the compression stroke other than that of the exhaust stroke.

Adjustment of Ignition Time

That the ignition lead angle is not correct will cause a series of problem that engine is difficult to start, power decrease, oil consumption increase, engine overheats, burning is not complete, emission exceed standard, use life reduce and so on. So should adjust the ignition lead angle at first

Need not adjust the ignition timing if engine without contact ignition. If the ignition system is abnormal, should check electronic ignition, high-voltage coil, charging on the generator and trigger coil etc.

After properly timing, pull off the tensioner locking key and coat the mixture of engine oil and molybdenum disulfide on the tensioner to make it tensioned; mount the sprocket retaining plate and retaining bolt.

While aligning

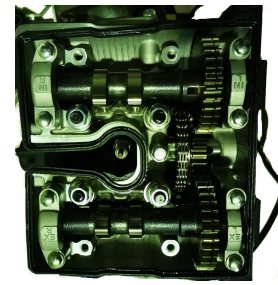

The boss is in the center of the hole



Cylinder pressure

When the engine fails to start or is difficult to start, or when questioning the cylinder pressure is abnormal after other possible faults have been excluded, check the cylinder pressure.

Cylinder pressure: $\geq 1.3\text{MPa}/1500\text{r/min}$.

While testing, remove the spark plug and mount a pressure gauge at the position where the spark plug is mounted; fully open the throttle bar and electronically start the engine, and then check all connecting points of the pressure gauge for gas leak. Zero the pressure gauge and restart the engine until the pressure gauge reading stops rising. The maximum reading of the pressure gauge can usually be reached after 1 or 2 startups. Such maximum reading shall be the cylinder pressure. Upon completion of testing, mount the spark plug to its original position.

The main reasons for insufficient cylinder pressure include:

- **Incorrect valve clearance adjusted**
- **Valve leakage**
- **Cylinder head sealing gasket ablated**
- **Piston ring or cylinder worn**
- **Piston ring worn**

The main reasons for excessive pressure include:

Presence of accumulated carbon inside the combustion chamber or on the piston top

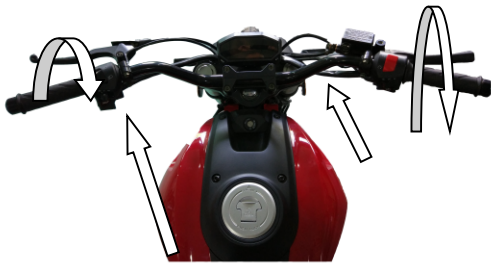

Press engine's start button

Turn the key clockwise

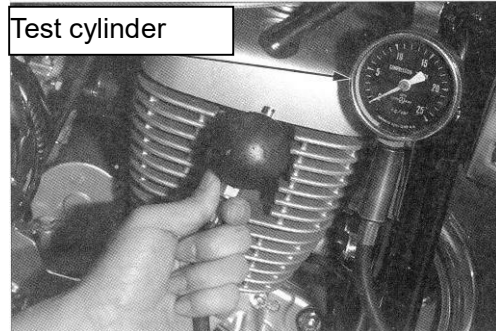

Timing chain tension

Start the engine to run at idle speed.

Carefully listen to the sound given off by the running engine: if the timing chain gives off ringing sound "Dah-Dah", it indicates insufficient tension of the chain tensioner, replace it with a new one.

To replace the chain tensioner:

Unscrew the 2-M6×16 socket cap screw to remove the

sealing washer and detach the old chain tensioner. Take care not let the sealing washer and so on fall into the crankcase. Insert the tensioner 4 locking key  into the tail end of the new chain tensioner, turn and retract the front end of the tensioner and lock it, then replace with a new sealing washer, mount the new chain tensioner and fasten.

Pull off the tensioner locking key to tension the timing chain.

Replace with a new sealing washer and screw up the bolts on the tail end of the chain tensioner.

Valve clearance

⚠ Notice:

While adjusting the valve clearance, the engine shall be cold.

(Temperature <math>< 35^{\circ}\text{C}</math>)

Noise will stem from too big valve clearance. However if there is too small gap or even no gap at all, closing of the valve will be hindered, which will cause many problems such as engine stall, power loss, etc. Therefore, the valve clearance must be checked periodically.

The valve clearance should be inspected and adjusted on a cold engine by the following procedures:

Remove the caps of the central hole and the ignition timing observation hole on the left crankcase cover.

Remove the caps of the two air valves on the cylinder head.

Upper eyehole cover

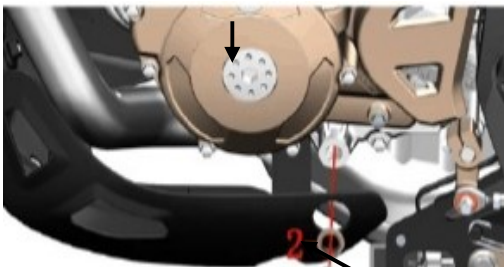

Eyehole cover

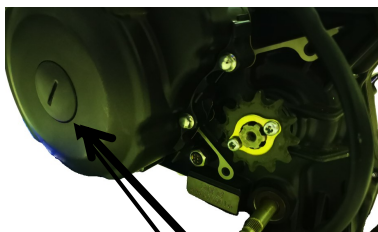

Confirm the upper dead

Turn the nut of the flywheel clockwise until the engraved "T" mark on the flywheel aligns with the engraved line on the top of the crankcase cover, and both intake and exhaust rock arms do not move but stop at their loosest position, which shows that the piston is in its top dead center position of the compressing stroke. If the "T" mark is near its right position but rock arms will move apparently when flywheel rotate a small angle, the flywheel is not in the compressing stroke but exhaust/intake stroke. In this case, continuously turn the flywheel clockwise for 360 degrees to the top dead center position of the compressing stroke, where the valve clearance can be adjusted. Afterwards, check the valve clearance by inserting a clearance gage into the gap between adjusting screw and the end of the valve.

The specified valve clearance is : 0.06-0.08mm for intake valve and 0.06-0.08mm for exhaust valve respectively.

If clearance adjustment is needed, loosen the locking nut on the rock arm, turn the adjusting nut till a slight resistance is felt on the inserted right clearance gage.

At the end of the adjustment, tighten the "Locking out" to prevent loosening and another check to make sure that the valve clearance is OK before all those dismantled caps are refitted on.

While adjusting, unscrew the retaining nut and then turn the adjusting screw until you feel that the clearance gauge is slightly pulled. Then secure the adjusting screw using the valve adjusting tool , and then screw the retaining screw. And finally, check the valve clearance.

Air filter

Cleaning and replacement of air filter

- Remove the left side covers Handle it carefully to avoid scraping.
- Remove 6 screws, remove Air filter cover



 **Description**

- 1 Remove the filter element and check whether it is in normal condition. This is a paper filter element, of which the surface can be cleaned with compressed air; if the filter element is too dirty, broken or damaged, replace it;**
- 2 While driving in a more dusty area, the time period for cleaning and replacing air filter element shall be shorter.**
- 3 Keeping the cleanness of the air filter may improve the engine's operating efficiency and prolong its life span.**



Filter element

Air filter cover

Idle speed

 **Notice**

Check and adjust the idle speed after all other items of the engine have been adjusted to the specified ranges.

For this model, the idle speed is controlled by an ECU. Since the intake flow at idle speed has been properly adjusted upon delivery, do not adjust the idle speed adjusting screw as desired. In case the idle speed is unsteady, zero or too high, find out the possible causes with the troubleshooting method for the EMS system and eliminate the trouble.

Under the monitoring of the maintaining and diagnostic instrument, check whether the ignition advance angle is between 0° -15° . If the ignition advance angle is more than 15° , it indicates the throttle valve's intake flow at idle speed is insufficient, and at this point, the idle speed is unstable or null; if the ignition advance angle is less than 0° , it indicates the intake flow at idle speed is too big, and at this point, the idle speed is often as high as more than 1800 r/min. Only under the above two cases, unscrew the retaining nut and adjust the idle speed adjusting screw to let the intake flow reach the specified flow.

Idle speed **1500 r/min ± 150 r/min.**

After adjusting toe-in, remember to screw up the retaining nut.





Throttle control

First, check whether the throttle control line is deformed, twisted or damaged.

Then, measure the throttle bar free stroke. Turn the bar to lean it against one side of the free stroke, and draw a straight line between the bar and the balance weight with a mark pen, and then turn the bar to lean it against the other side of the free stroke; measure the distance the straight line staggers, i.e. the throttle bar free stroke.

Free stroke 2-6mm.

If the free stroke is insufficient or too big, make adjustment.

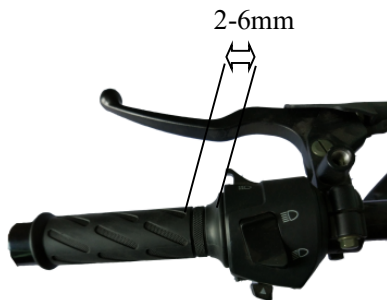

Adjusting methods:

Fine adjustment: Pull open the rubber lagging, unscrew the retaining nut A, and turn the adjusting solenoid to adjust to a satisfied free stroke. And then screw up the retaining nut A and mount the protective rubber lagging.

Coarse adjustment:

If the fine adjustment is not satisfying, separate the

throttle control line with throttle valve body and unscrew the retaining nut B to make adjust the free stroke in a larger range. Screw up the retaining but B after the adjustment.

Check whether the throttle can turn smoothly from full open to full close at any position. If there is clogging, adjust or replace it.

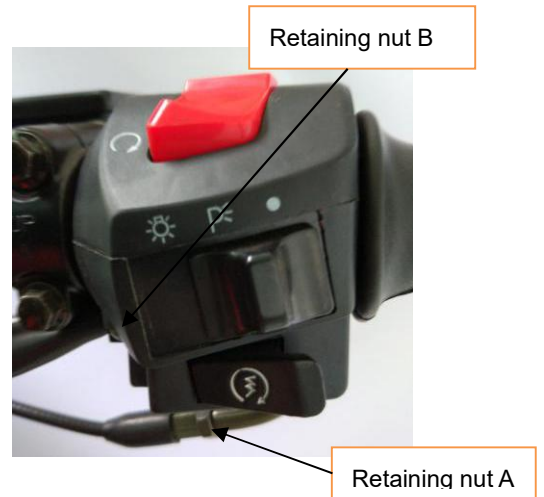

Brake system

Check the front brake handle free stroke.

The brake handle free stroke 10-20mm.

10-20mm

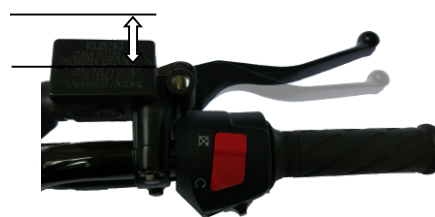

Brake fluid level inspection:

Check the brake fluid level in the front brake cylinder: if the level is too low but not emptied, directly refill brake fluid (DOT 4 brake fluid).

If the brake fluid inside the cylinder is found cloudy, impure or smelt, Drain and refill the brake fluid. Refer to the brake fluid vacuum filling method in the next section.

I If the brake fluid in both the front cylinders is drained,

bleed air from the deflating valve of the brake caliper with a vacuum pump, and then refill brake fluid into the cylinder.

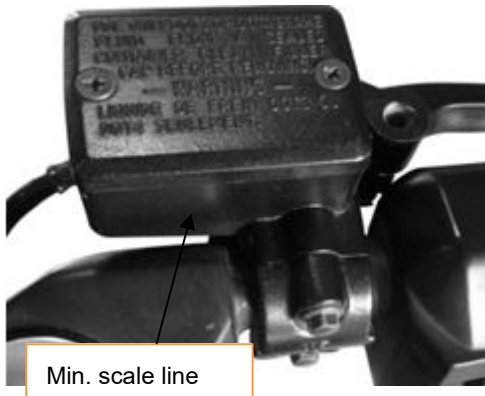

Brake fluid vacuum filling method:

This method is only applicable to refilling brake fluid for new vehicles or when the brake fluid in the cylinder is drained.

1. Bleed air from the deflating valve of the vacuum pump's caliper
2. Open the cover of brake cylinder cover and refill brake fluid.



3. Actuate the brake handle, exhaust the air in the dead corner of the brake caliper.



4.

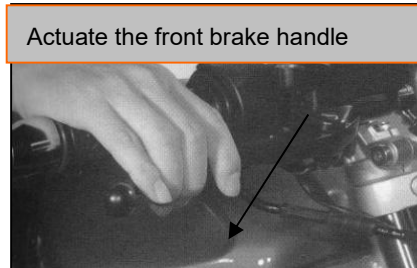

5. When the vacuum pump has fully exhausted the air inside the brake caliper, after the brake fluid is pumped out, firmly nip the handle or completely push down quickly screw the deflating valve bolt, with the torque being 7-9 N.m.
6. Mount the brake cylinder cover with the sealing gasket flattened, and replace with new sealing gasket as required.
7. After refilling, check the oil cup, hydraulic brake hose and all connecting pieces for leakage.

⚠ Notice

- 1 **The brake fluid shall be DOT 4 non-petroleum base brake fluid.**

The brake fluid can't be mixed with other

- 2 **Impurities; otherwise the braking performance shall be reduced due to chemical change.**

🚫 Caution

The brake fluid is strongly corrosive, never splash it onto the surfaces of sprays painted or plastic pieces;

in case it splashes into the eyes or on the skin,
immediately flush with large amounts of fresh water
and see a doctor.

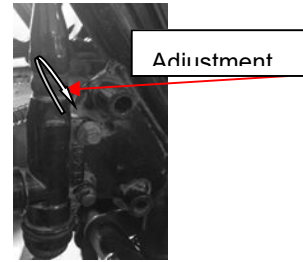

Brake piece checking

Operating brake, if the wears limit line of the brake shoe touch to the side of the brake disc. It shows that the brake shoe has touched the wear limit

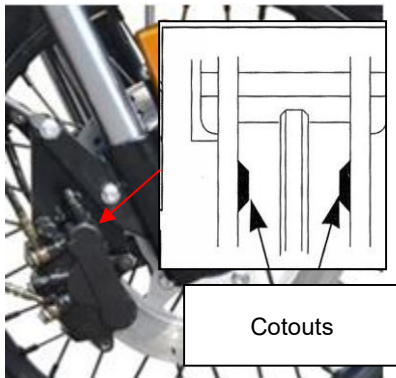

The brake piece checking

(1) Pulling the rear brake, checking the wear and tear of the brake shoe. If the mark "△" on the drum brake cover and also on the brake cam alignment, shows the brake shoe has been touched the wear limit. Please change it.

(2) If it needs to be changed. Please go to the designated special maintenance station. And it is better to use the parts from our company.

⚠ Caution

Please change the brake shoe in time if it has been touched the wear limit. Otherwise it would cause accidents by the lack of strength.

Rear Brake

Pushing the brake pedal by hand, checking the resistance, to confirm the move of the brake pedal whether is good. If not, it could be adjusted by adjusting the rear brake adjustment nut. Twirling the nut to adjust the pedal stroke. Pushing the brake pedal by hand till feeling resistance . Validation the pedal free stroke whether is in the scope of regulations.

Substitution of the brake pads

Press the brake caliper towards the brake disc, and put the brake piston back into its basic position. Remove the clips and pull out the bolt. Clean up the brake caliper and the support with compressed air. Check whether or not the sleeves of guiding bolts in damaged or not, and grease the bolts if necessary.

Brake pedal free stroke: 20-30mm



When installing the brake pads, be sure to check whether or not the sliding metallic sheet is correctly set up on the caliper support and in the spring.

Running system

Tire specifications and tire pressure

Check the tire pressure with a tire pressure gauge to see whether the pressure conforms to the recommended

value.

Tire specifications and recommended tire pressure:

specs	Front tire	Rear tire
	110/90-17	130/80-17
Cold tire air pressure	Front tire	Front tire
	225kPa	225kPa

If the tire pressure can't reach the specified requirements, check the tire for cuts, embedded iron nail or other sharp articles.

⚠ Caution

The tire pressure measured when the tire is cooled down shall be the correct tire pressure.

Spoke

Check the wheel for loosened or broken spokes. Screw the loosened spokes to the specified torque with a spoke nut fastening tool . The spoke nut torque: 2.45-4.9N.m.

If any spoke is broken or cracked, replace it as soon as possible

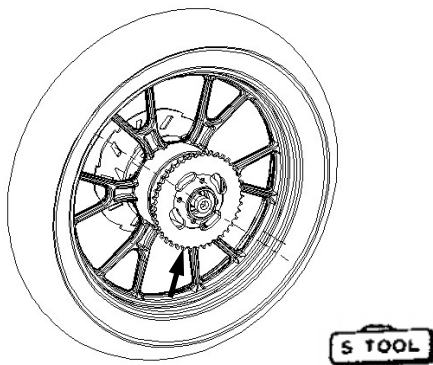

Clutch control line

Clutch is the key part of transmitting power in motorcycle transmission system, should adjust it according to the following overhauling content. The content is the free stroke of clutch control handle(general is 10-20mm), some venial need adjust the adjusting screw of declutch

mechanism.

Check the clutch operating handle free stroke. Clutch operating handle free stroke: 10-20mm.

10-20mm

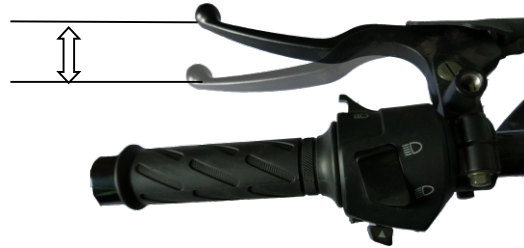

Adjusting methods:

Fine adjustment: Pull open the rubber lagging, unscrew the retaining nut, and turn the adjusting nut to adjust to a satisfied free stroke. And then screw up the retaining nut and mount the protective rubber lagging.

If a satisfactory free stroke can't be achieved by fine adjustment, remove the clutch control line on the handle end to adjust the engine end.

Adjusting methods:

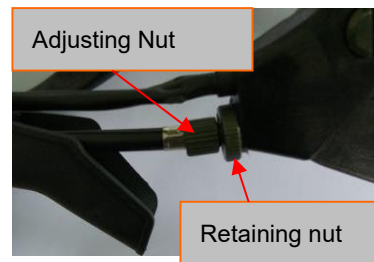

Coarse adjustment:

Remove the clutch control line on the handle end, and then remove the clutch operating arm on the engine end; turn the clutch operating arm by a proper angle and remount it, and then mount the clutch control line, finally adjust it to a satisfied free stroke according to the fine adjustment.

protective rubber lagging

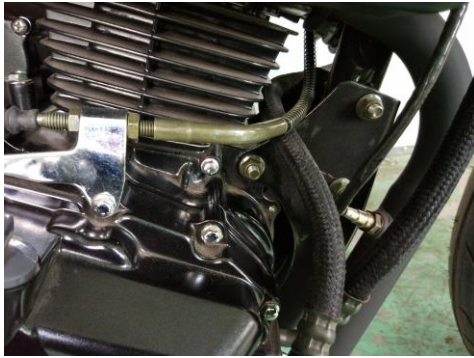

⚠ Notice:

Always ensure the clutch operating handle has the proper free stroke! Being too loose will cause a failure of the clutch detachment, while being too tight will cause poor clutch engagement thus damaging the clutch

Driving chain

Driving chain tension inspection

Park the motorcycle on level ground with main stand, and shift the transmission to the neutral position. Check the driving chain tension. Press the chain with a finger up and down to check the amount of movement of the lower chain.

Driving chain tension: 10-20mm.

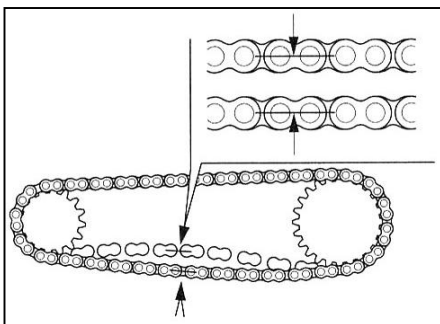

If the chain is too loose or too tight, make adjustment.

Adjusting methods:

Unscrew the rear wheel spindle nut and turn the adjusting bolt on the chain adjuster until the specified tension is achieved, and then fasten the rear wheel spindle nut, and

check the flexibility for free rotation of the rear wheel and the consistency of the front and rear wheels.

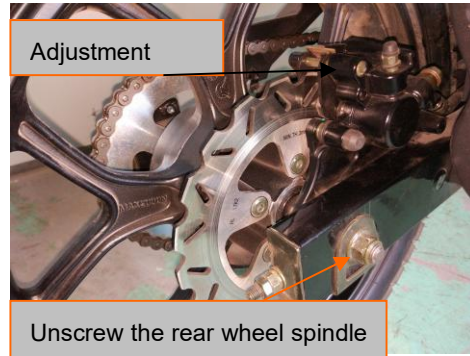

⚠ Warning:

The rear wheel spindle nut must be firmly screwed up to the tightening torque of 60-90N.m.

Inspect the abrasion of major / minor sprocket. In case of serious tooth abrasion, teeth missing or broken teeth, replace it.

Inspect the abrasion of major / minor sprocket. In case of serious tooth abrasion, teeth missing or broken teeth, replace it.

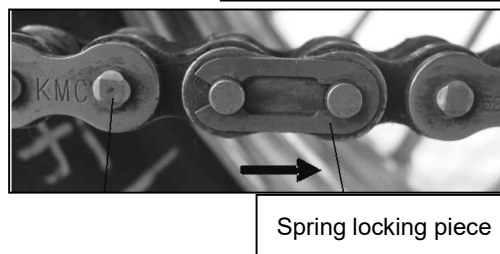

⚠ Notice:

The scale lines of the chain adjuster on both sides must be consistent with each other.

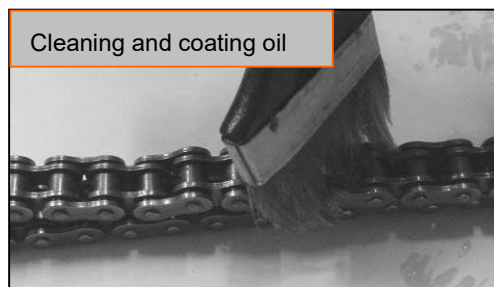

Selected washing oil shall be in corrosive to the oil seal; while assembling the chain, the locking piece coupling

spindle shall be coated with appropriate amount of chain-specific lubricating oil.

⚠ Warning:

While mounting the spring locking pieces, its opening end shall be in the opposite direction with the normal movement of the driving chain.

Battery Checking

Removal of accumulator

Open the left side cover.

Clean away dust and corrosive from the surface of the battery.



Remove the negative, then the positive pole of the accumulator; unscrew and remove the loosen battery strap

Measure the voltage of the negative pole with a voltmeter; if it is less than 12V, recharge it with a charge power supply.

Seriously corroded conductor connectors of the battery shall be replaced.

Installation of accumulator

Installation is in the reverse order of removal. While connecting the poles, connect the positive pole first.

⚠ Warning:

- 1 In this model, both the startup and EMS system are completely powered with accumulator. Therefore, it is quite important to ensure sufficient electric quantity of accumulator, otherwise, startup is impossible.
- 2 Never fill in tap water, because this will shorten the accumulator's life span.
- 3 To dismantle battery ,disconnect the negative(-)electrode before the positive(+)one, and vice versa in installation .Ensure against any contact of the positive(+)electrode with the vehicle body.
- 4 Never have the electrolyte level come over the upper mark line when adding distilled water .Otherwise overflow and corrosion will occur.
- 5 The electrolyte contains sulfuric acid and will cause serious hurt to skin and eyes by contact. In case of contact with it, wash it off for 5 minutes and see a doctor immediately.

Brake lamp adjustment

If the rear breaks lamps abnormally light up and go out, adjust it by turning the adjusting nut. If the rear brake lamp switch is broken, replace it immediately. Pull down the right side cover

Pull out and pull off the patch plug of the rear brake lamp switch, and carefully pull out the rear brake lamp switch wire and remove the rear brake spring. Replace with new rear brake lamp switch and mount it in the reverse order.

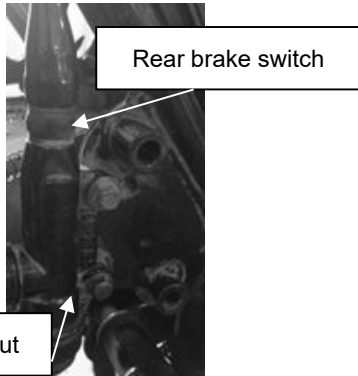

While installing, the wiring of the rear brake lamp shall be in strict accordance with the wiring diagram, and replace the buckle strip

While installing, the rear brake spring shall be reliably hooked with the pin hole on the rear brake lamp switch. After replacement, adjustment shall still be carried out to the rear brake lamp switch.

Replacement of Fuse

Set the ignition switch to "OFF" position. The specified fuse tube of 15A/10A should be used for main fuse replacement, and a 10A fuse tube for FAI injection nozzle.

Open the left side cover, remove the fuse holder on the side of the battery and replace the fuse tube.

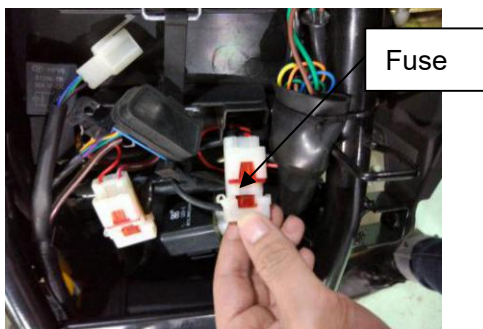

If the new fuse tube is broken again as soon as it is fitted on, it means that somewhere of the electric parts is shorted unexpectedly.

⚠ Caution

Do not use any fuse over 15A/10A

Be sure not to wash the battery when washing the vehicle.

Headlamp dimming

Before driving, check the brightness, direction, etc. of the headlamp.

The adjustment can be made to the headlamp in the left / right and vertical directions.

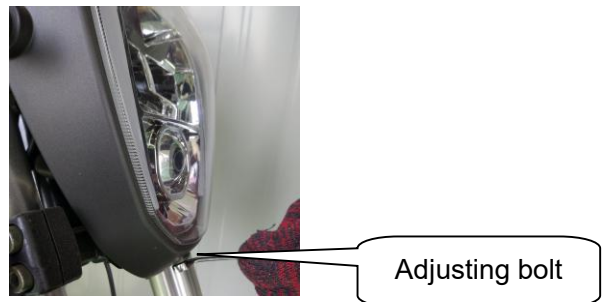

- Loose the screw to disassemble the headlight.
- Rotating , directly unplugging
- Rotating and disassemble the bulb.
- Install the new bulb in reverse order

Headlight bulb 12V55W

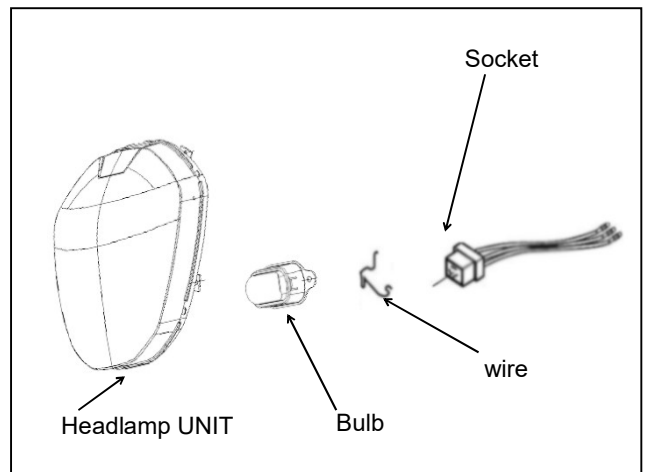

Position lamp bulb

- Unplugging the sidelight seat
- Unplugging the sidelight bulb

Taillight、Taillight bulb

- Loosen the screws, remove the taillight lampshade
- Lightly rotate taillight seat, take out the seat and bulb.
- Lightly press bulb, rotate in counter-clockwise.
- Install new bulb in opposite order as below.

Taillight bulb: 12V/9W/3W

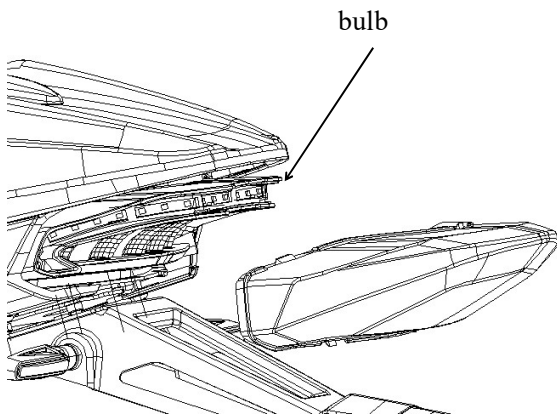

Front and rear lamp bulb

- Loosen the screws, remove the lamp lampshade
- Lightly press bulb, rotate in counter-clockwise.
- Install new bulb in opposite order as below.

Front and rear lamp bulb 12V10W

Steering stem bearing



Lift the motorcycle with a jack or other support with the

front wheel being apart from the ground surface, and check whether the steering handle can rotate freely; if the steering handle cannot rotate in balance, or has axial looseness or jamming, adjust the front fork stem adjusting nu

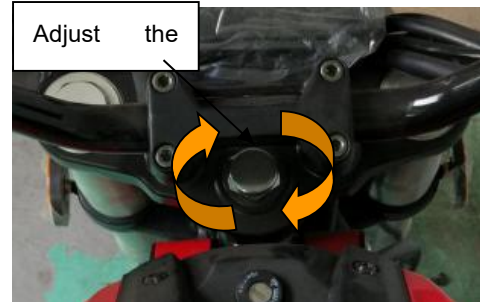

Suspension system

Front suspension

Make the front brake in braking state and press the front fork bracket for several times, and check the front suspension for normal operation.

If abnormal noise or "Crack" sound is heard, check all the fasteners and screw them up to the specified torques.



Front suspension inspection

Rear suspension

Forcibly press the rear end of the seat cushion with the rear suspension, and check the rear fork spindle sleeve for abrasion or damage. If it is damaged, replace it. Check whether the whole suspension assembly is mounted securely, and whether it is damaged or deformed



Bolts, nuts and fasteners

All the bolts, nuts and fasteners shall be screwed up as per the maintenance period table. And check all the cotter pins, safety gripping gears, locks, etc.

4、 Fuel system

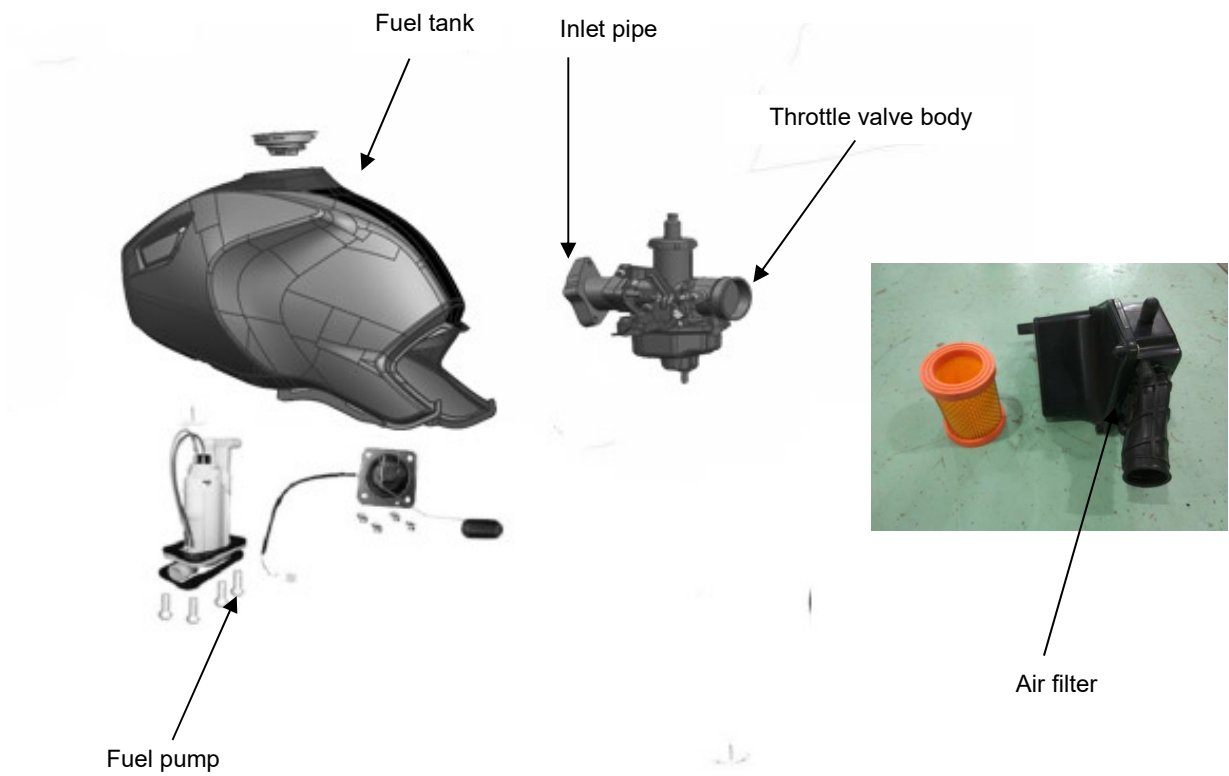

Fuel system

Maintenance notice	Disassembly and assembly of fuel tank
Troubleshooting	Removal and installation of air filter
Removal and installation of fuel tank	Removal and installation of carburetor

Maintenance notice

This section introduces the knowledge related to the fuel system.

ⓘ CAUTION

- **Pay special attention to fire prevention while dealing with gasoline!**

Take care of the mounting position of such sealing members as the O-ring while removing various parts of the fuel system.

While reassembling, always use new sealing members such as an O-ring.

Technical specifications

Throat opening diameter	Φ16mm equivalent
Idle speed	1500r/min ± 150 r/min
Throttle handle free stroke	1~3mm

Troubleshooting

- Engine ignition is ok, but it does not start
 - 1 No fuel or insufficient fuel in the fuel tank
 - 2 Too much fuel enters the cylinder;
 - 3 Air filter is clogged;
 - 4 Spark plug fails;
 - 5 Fuel tube does not flow well;
 - 6 Fuel quality problem (containing moisture);
 - 7 Fuel is stored too long;
 - 8 Fuel pump failure;
 - 9 Injector failure (clogged)

Removal and installation of fuel tank

Disassemble step

1. Remove the seat



2. Unscrew one connecting bolts



3. Loosen the tube clamp and pull off the fuel tube
4. Pull off the fuel pump control wire patch plug.



5. Remove the fuel tank.



To avoid fuel line contamination, clog the joint with fireproof fabric after pulling off the fuel tube.



Installation steps

The installation procedures are the removal procedures in reverse order.

While installing, note that the wiring of the fuel pump control wire shall be in strict accordance with the wiring diagram. Avoid fuel line contamination.

Removal and installation of air filter

Refer to the section “Inspection and Adjustment—Air Filter”,

It is unnecessary to remove the air cleaner assy from the frame when performing maintenance on filter element; take out the filter element for cleaning or replacement.

1. Remove covering, right
2. Remove Air cleaner cover, right
3. Take out the filter element for cleaning or replacement.



Remove and installation of throttle body

Disassemble step:

1. Removal of rear wheel



2. Removal of seat



3. Removal of fuel tank



4. Loosen inlet pipe clip;
5. Remove throttle body (including the fuel injector).



Installation steps:

The installation procedures are the removal procedures in reverse order. While installing, the locating slot must be aligned with the locating lobe of throttle body

 **Warning:**

Do not further disassemble the removed throttle body; in case several sensors on it need to be changed, proceed under the instruction of an EMS system technician.

Aintenance of Air Cleaner

Component description	Damage form	Trouble symptom of motorcycle	Repair method
Air cleaner	Too much dust deposit on the filtering element.	The engine is difficult to start. Insufficient engine output; Poor performance of engine during idle run. Excessive fuel consumption. The exhaust muffler pipe fumes strongly (black).	Clean the filtering element. Clean
	The filtering element is fractured or chipped	Engine air suction noise is too loud	Replace the filtering element.

5、Removal and installation of engine

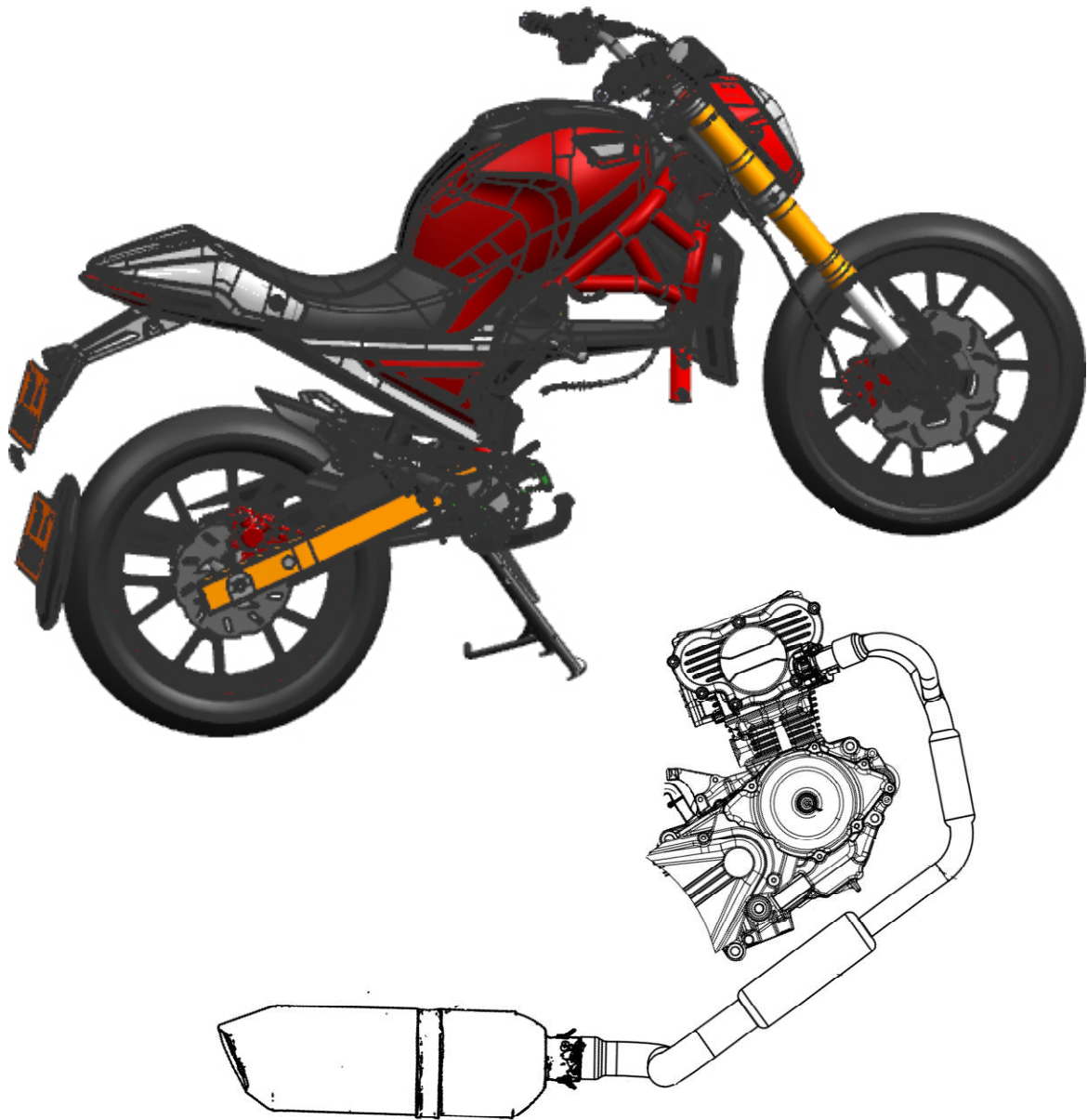

Removal and installation of engine

Maintenance notice

Installation of engine

Removal of engine

Maintenance notice

It is only necessary to remove the engine from the frame when performing maintenance on the engine's crankshaft, balancing shaft, driving parts, etc. It is unnecessary to remove the engine from the frame when performing maintenance on other parts of the engine.

Before removing the engine, park the motorcycle on level ground, and completely drain engine lubricating oil.

To maintain the heat engine parts including cylinder head, cylinder body, piston, etc., it is necessary to remove the coverings, fuel tank, throttle body, air filter assembly, etc.

To remove the engine's right crankcase cover for maintenance, it is necessary to remove the rear brake pedal

To remove the engine's left front cover for maintenance, it is necessary to remove the gear shift pedal, left rear cover, etc.

Installation is in the reverse order of removal.

While reinstalling, all wirings shall be carried out in accordance with the wiring diagram, and replace the removed buckle strip

Specification

Net weight of engine **24 ± 1kg**

Engine oil volume **1.6L**

Key torque values

Engine hanging bolt **M8: 20-30N.m**

M10: 30-40N.m

Rear fork shaft **60-70N.m**

Removal of engine

1. Park the motorcycle on the plane ground, and completely drain the engine lubricating oil.

Screw plug for oil draining

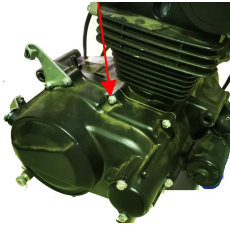

2. Remove side cover, seat and fuel tank



3. Remove muffler



4. Remove engine cycle tube



5. Remove Left /Right cylinder head connecting pipe



6. Detach the earth wire from the negative pole of the battery.



7. Remove clutch cable



8. Remove the starting motor wire.



9. Remove the high voltage wire



10. Remove the magnetic motor, gear display line and hit the line wire



11. Remove the gear shift pedal and left rear cover



12. To remove the rear brake pedal

13. Pull off the engine sensor connector.



14. Remove the inlet pipe connected to the engine bolt



15. Remove the engine hanging plate.

- Front suspension



16. To take out the rear fork shaft and move the rear fork backwards:



- Remove the drive chain
- Remove the rear absorber and rear fork connecting bolt;

- Unscrew the nut and take out the rear fork shaft;

- Take out the rear fork backwards



- Loosen the nut and remove the lower hanging bolt.



- Move the engine slowly from the right.



Installation of engine

The installation of engine is in the reverse order of removal of engine.

During installation, note that the wiring of cable shall be in strict accordance with the wiring diagram.

Remove the 4 engine bracket and the frame connecting bolt

Remove the 2 front suspension bolt

Remove the 2 rear suspension bolt

Remove the drive chain

Move the engine slowly from the right.

6. Cylinder head, cylinder and piston

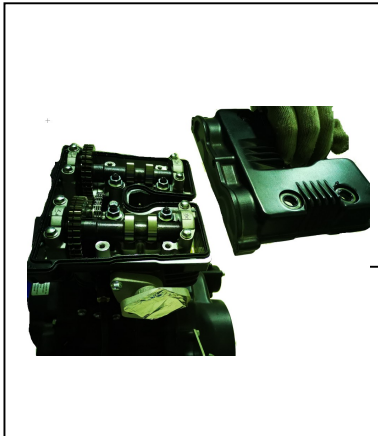

Cylinder head cover

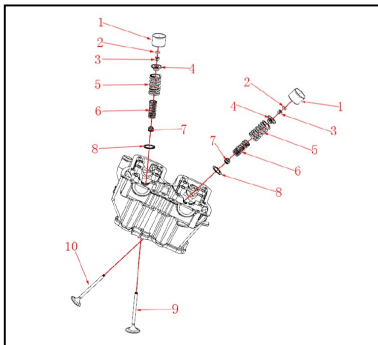

Cylinder head

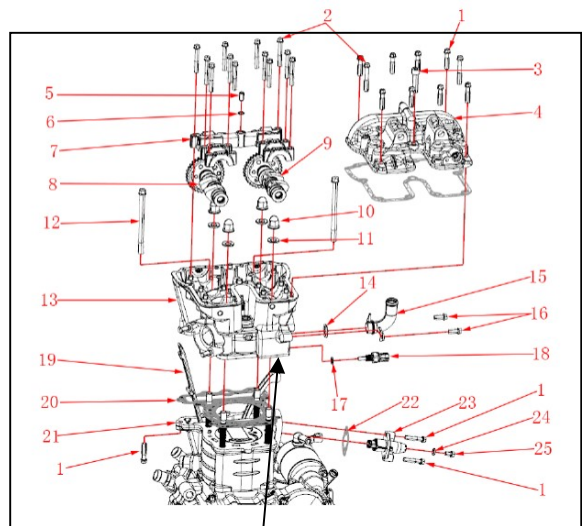

Cylinder

Cylinder head, cylinder and piston

Maintenance notice	Cylinder head
Troubleshooting	Cylinder
Cylinder head cover	Piston
Camshaft	

Maintenance notice

The lubrication of the camshaft and rocker arm is implemented by pumping oil by the oil pump through the oil troughs of the cylinder, cylinder head and cylinder head cover; before assembling, please check whether the oil troughs are unobstructed and clean them up properly.

Before assembling, clean all parts and components with cleaning agent and dry them with compressed air.

While assembling, coat engine oil and molybdenum disulfide lubricant on the protruding surface of the camshaft for preliminary lubrication.

Be careful not to damage the cylinder wall and piston.

Technical specifications & maintenance benchmark

Item		Standard value	Maintenance limit value
Camshaft	Camshaft lift: IN	5.15mm	5.21mm
	Camshaft lift: EX	5.0mm	5.06mm
Cylinder head	Planeness	0.03mm	0.05mm
Valve spring	Internal spring free length	36.5mm	36mm
	External spring free length	36.5mm	36mm
Valve	IN Valve stem external diameter	φ 5mm	φ 4.975mm
	Conduit inner diameter	φ 5 mm	φ 5.012mm
	EX Valve stem external diameter	φ 5mm	φ 4.955mm
	Conduit inner diameter:	φ 5mm	φ 5.012mm
Valve clearance	IN	0.15mm~0.20mm	/
	EX	0.20mm~0.30mm	/
Cylinder	Internal diameter	Φ40.1mm~Φ40.1mm	Φ40.1mm
	Roundness	/	0.003
	Cylindricity	/	0.004

	Top planeness	/	0.05
Piston and piston pin	Piston external diameter	$\Phi 40 \sim \Phi 40.1 \text{ mm}$	$\Phi 40 \text{ mm}$
	Fit clearance with cylinder	0.01mm~0.04mm	0.04mm
	Piston pin external diameter	$\Phi 12.995 \text{ mm} \sim \Phi 13 \text{ mm}$	$\Phi 12.995 \text{ mm}$
	Piston pin hole inside diameter	$\Phi 13.002 \text{ mm} \sim \Phi 13.008 \text{ mm}$	$\Phi 13.008 \text{ mm}$
	Fit clearance	0.002mm~0.013mm	0.013mm
Connecting rod small end	Internal diameter	$\Phi 13.013 \text{ mm} \sim \Phi 13.028 \text{ mm}$	$\Phi 13.028 \text{ mm}$
	Clearance with piston pin	0.013mm~0.033mm	0.033mm
Piston ring	First ring gap clearance	0.015mm~0.05mm	0.05mm
	Second ring gap clearance	0.015mm~0.05mm	0.05mm
	First ring side clearance	0.002mm~0.013mm	0.013mm
	Second ring side clearance	0.002mm~0.013mm	0.013mm
	Oil ring side clearance	0.002mm~0.013mm	0.013mm

Key torque values

Cylinder head cover connecting bolt	8-12 N.m
Cylinder bolt	40-50 N.m
Timing driven sprocket bolt	8-12 N.m
Spark plug	18-25 N.m
Pensioner plate fastening bolt	8-12 N.m

Troubleshooting

- Low cylinder pressure
 1. Valve:
 - Incorrect valve clearance adjusted;
 - Valve ablated or bent;
 - Valve sealing failure;
 - Incorrect valve timing;
 - Valve spring damaged.
 2. Cylinder head:
 - Spark plug sealing failure;
 - Cylinder head gasket leaked or damaged;
 - Cylinder head cracked or blistered.
 3. Cylinder and piston:
 - Piston ring clearance too big or cracked;
 - Piston cracked or damaged;
 - Cylinder / piston ring worn.
- Excessive noise
 1. Incorrect valve adjustment;
 2. Valve jammed or valve spring broken;
 3. Camshaft worn or damaged;
 4. Timing chain too long, worn or damaged;
 5. Timing chain tensioned failure;
 6. Timing driven sprocket worn;
 7. Cylinder / piston worn;
 8. Rocker arm / Rocker-arm shaft worn;
 9. Piston pin bore / piston pin worn.
- Overheat / knocking (cylinder pressure too high)
 1. Too much carbon deposited in combustion chamber.
- Black smoke from exhaust
 1. Valve guide worn;
 2. Oil shield leaked or damaged;
 3. Cylinder / piston / piston ring worn;
 4. Piston ring clearance too big;
 5. Piston ring incorrectly installed;
 6. Piston or cylinder wall scratched or scuffed.

Cylinder head cover

To remove the cylinder head cover:

1. Remove the lower / upper eyehole covers and turn the crankshaft so that the piston is at the upper dead point of the compression stroke.

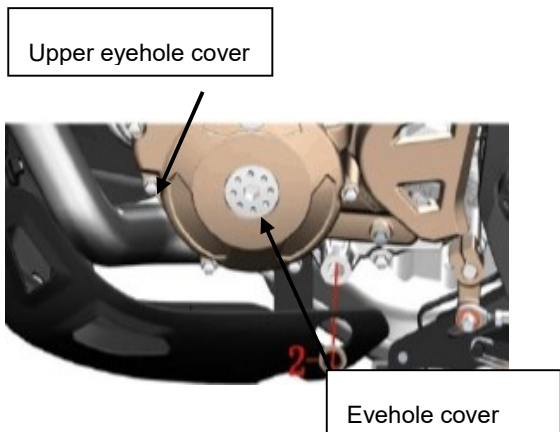

2. Remove the valve cover, connecting bolt, etc.
3. Remove the cylinder head connecting bolt.
4. Remove the cylinder head cover.

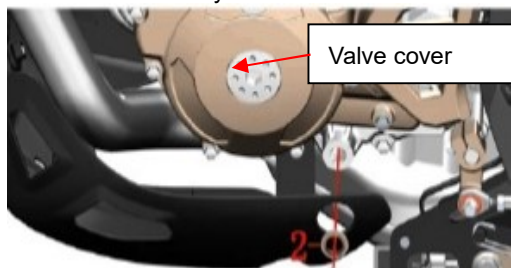

⚠ Caution

Do not drop the location pin into the crankcase.

To mount the cylinder head cover:

1. Turn the crankshaft so that the piston is at the upper dead point of the compression stroke.
2. Remember to confirm the location pin.
3. Mount the cylinder head cover and the sealing gasket.
4. Mount the cylinder head connecting bolt. ; tightening

torque is 12N.m

5. Confirm the valve clearance, and make adjustment with a valve clearance adjusting tool as required.
6. Mount the valve cover, etc

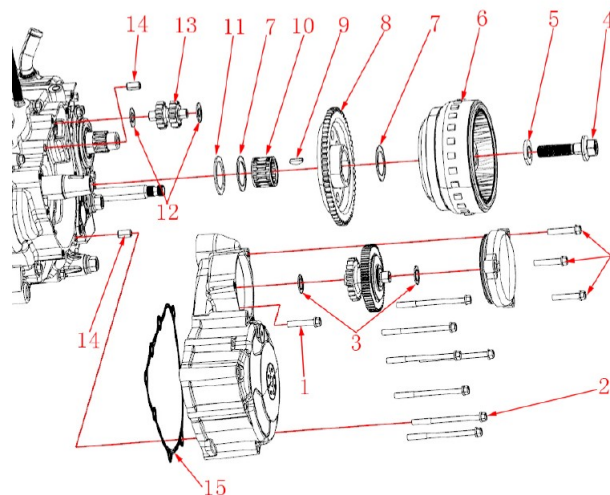

7. Connect the phase sensor and mount the eyehole cover and upper eyehole cover in turn.

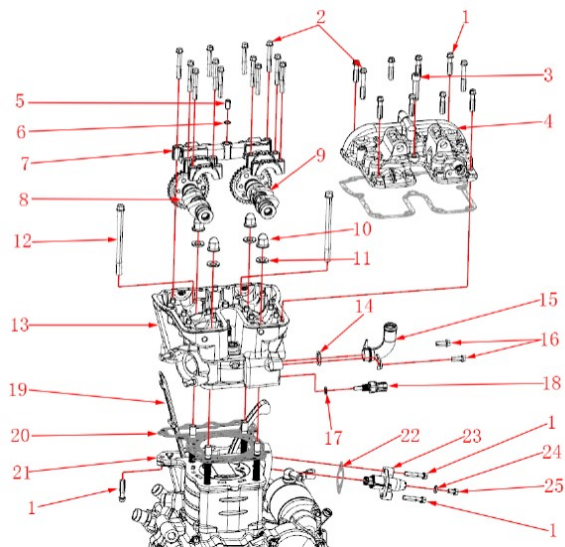

Camshaft

To remove the camshaft:

1. Remove the lower / upper eyehole cover and turn the crankshaft so that the piston is at the upper dead point of the compression stroke.
2. Remove the cylinder head cover (See Removal of cylinder head cover).

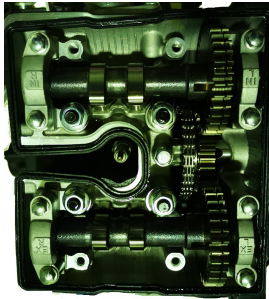

3. Remove the camshaft end cover, loosen the screw and washer at the tail end of the tensioner; turn the screw clockwise with the tensioner locking key so that the tensioner is loosened and locked.

Tensioner

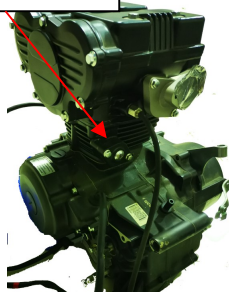

4. Remove the timing driven sprocket bolt

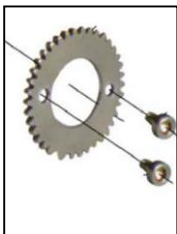

5. Remove the camshaft retaining pins
6. Remove the camshaft bearings

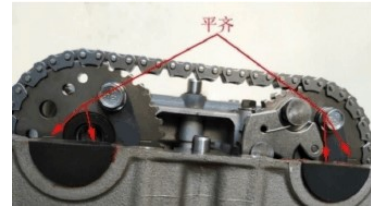

7. Strip the timing chain from the timing driven sprocket, and remove the timing driven sprocket.
8. Remove the camshaft

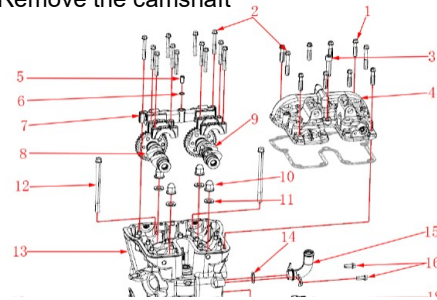

⚠ Caution

Do not drop the timing chain into the crankcase.

To mount the camshaft:

1. Turn the crankshaft so that the piston is at the upper dead point of the compression stroke and the scale line "1" on the rotor is aligned with the triangular indication mark on the left front cover.
2. Clean all parts and components, coat the mixture of engine oil and molybdenum disulfide on the protruding surface of the camshaft, and coat oil engine on the journal part.
3. Mount the camshaft retaining pins, camshaft, camshaft bearings and timing driven sprocket; let the basic circle part of the camshaft facing up while timing.

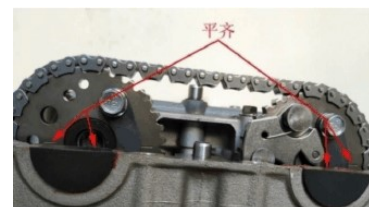

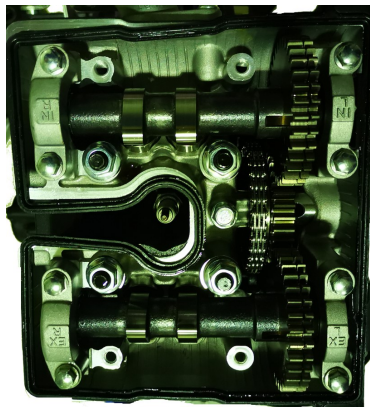

4. After properly timing, pull off the tensioner locking key and coat the mixture of engine oil and molybdenum disulfide on the tensioner to make it tensioned; mount the sprocket retaining plate and retaining bolt
5. Mount the bolt and washer at the tail end of the tensioner.

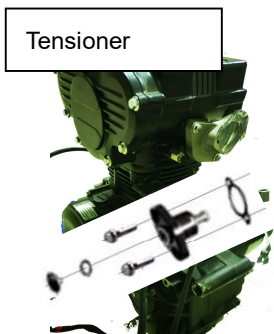

6. Mount the cylinder head cover (See Installation of cylinder head cover), and adjust the valve clearance
7. Connect the phase sensor and mount the eyehole cover and upper eyehole cover in turn.

⚠ Caution

When the tensioner is not tensioned, never turn the crankshaft for fear of interlocking the teeth while timing.

Camshaft inspection

Check the camshaft for abrasion, damage, oil through jamming, etc. and check whether the decompressor flying block can rotate and return smoothly.

Measure the maximum IN / EX lift.

Maintenance limit: IN ≥ 5.5057 mm, EX ≥ 5.515 mm

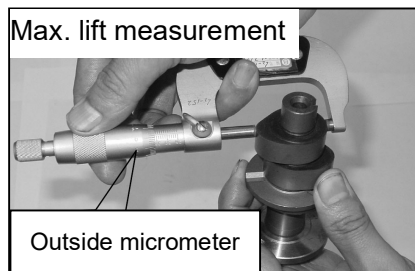

Cylinder head

To remove the cylinder head:

1. Remove the muffler exhaust pipe



2. Remove the engine cycle tube



3. Pull off the spark plug cap,



4. Unclamp the inlet pipe clip and remove the cylinder head hanging bolt.

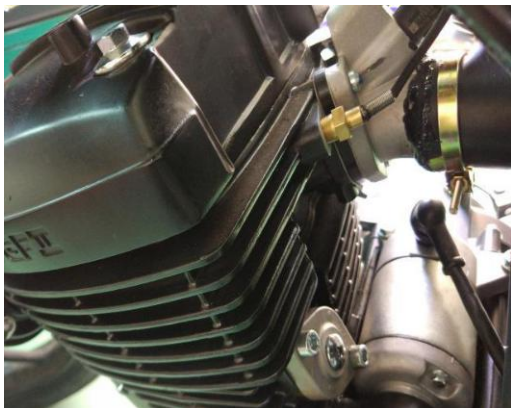

Installation is in the reverse order of removal. Precautions for installation:

1. Confirm the location pin; clean all parts and components, and check whether the cylinder head oil through is unobstructed, clean and free of leak.
2. Replace new cylinder head gasket
3. The tightening torque of cylinder bolt is 45N.m.

 **Warning:**

The cylinder head bolt must be fully screwed up to the tightening torque of 45N.m, and carry out 100% torque inspection.

5. Remove the cylinder bolt and washer.

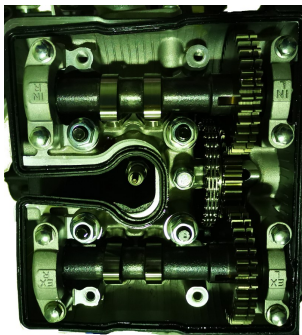

6. Remove the cylinder head and cylinder head gasket.

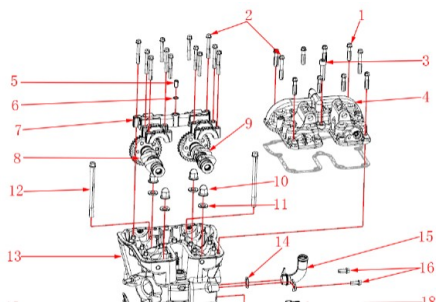

 **Caution**

Do not drop the location pin into the crankcase.

To mount the cylinder head:

Disassembly and assembly of cylinder head

Disassemble and assemble the cylinder head according to the following diagram.

Use the valve remover / replacer  to remove and mount the intake valve and exhaust valve.

The spark plug must be tightened to the specified tightening torque of 15~20N.m for fear of leak.

While mounting the intake / exhaust valve, coat the mixture of engine oil and molybdenum disulfide on valve stem for preliminary lubrication.

While mounting the stud, please use specified thread retaining adhesive.

While mounting the valve spring, let the sparse end face up.

 **Notice:**

Do not damage the oil shield lip while mounting.

The valve lock clamp must be mounted in place; dropout of the valve lock clamp is dangerous.

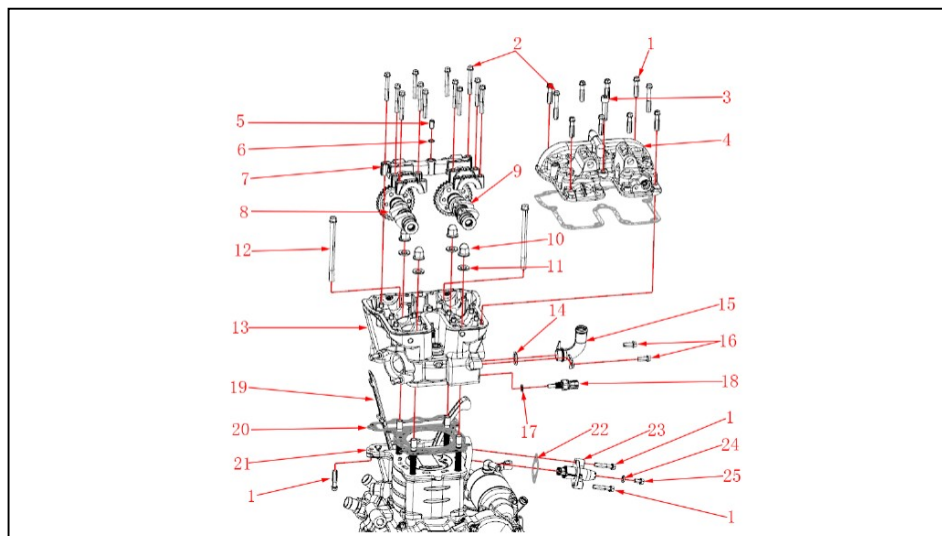

No.	Procedure	Quantit y	Remarks
1	M6×30 Hexagon flange face bolt	11	12±1.5N.m
2	M6×45 Hexagon flange face bolt	14	12±1.5N.m
3	G70.1Inner Hexagon M8×35	1	21±1.5N.m
4	Cylinder head part	1	
5	Φ8×15 Hollow Pin	5	Including 12 camshaft cover seats
6	Exhaust camshaft sub-assembly	1	
7	7.5×1.5 Fluoro Rubber o-ring	1	
8	Exhaust camshaft sub-assembly	4	60±5N.m
9	Intake camshaft subassembly	4	
10	M10×1.25 Cover flange nut	2	18-25N.m.
11	10.2×20×2 flat washer	1	8-12N.m.
12	M8×110 Hexagon flange face bolt	2	
13	Cylinder head part	1	
14	18×2.65 EPDM rubber	2	
15	Outlet manifold	1	
16	M6×16 Hexagon flange face bolt	2	
17	9×2 EPDM rubber	1	
18	Water temperature sensor	1	12±1.5N.m
19	Guide bar	1	
20	Block and head assembly	1	
21	Cylinder Block Assembly	1	
22	Tensioner gasket	1	
23	Tensioner	1	
24	6.3×12×1.6 Copper gasket	1	
25	M6×10 Top Pin Bolt	1	13±1.5N.m

Cylinder head inspection

Check whether the cylinder head is unobstructed, clean and free of leaks; check the cylinder head's spark plug hole and valve seat for cracks; insert the valve into the valve guide bore and move it up and down to check its movement; sway it back and forth and left and right to see whether there is significant sloshing.

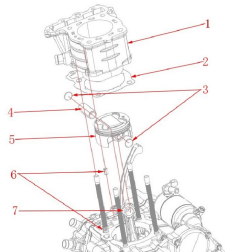

Check the cylinder head for deformation, and use the edge ruler and clearance gauge to inspect the planeness of the cylinder's joining surface.

Maintenance limit: $\leq 0.05\text{mm}$.

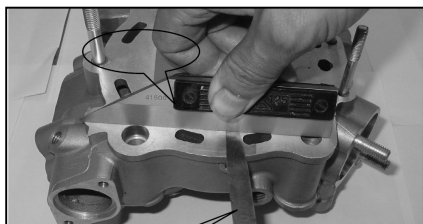

Measure the valve guide aperture.

Maintenance limit: $\leq \phi 4.53\text{mm}$

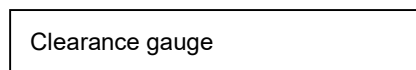

Measure the valve stem diameter.

Maintenance limit: IN $\geq \phi 5.15\text{mm}$,

EX $\geq \phi 5.15\text{mm}$

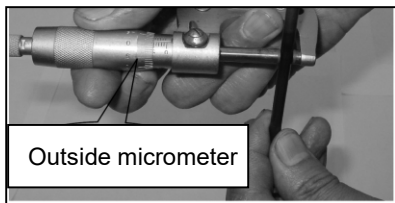

Measure the width of the valve contacting surface.

Maintenance limit: $\leq 1.7\text{mm}$

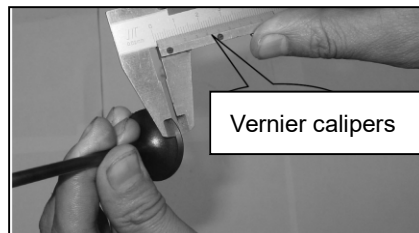

Measure the free length of the valve spring

Maintenance limit: Internal spring $\geq 35.00\text{mm}$

External spring $\geq 42.00\text{mm}$.

Calculate the clearance between the valve stem and valve guide

Maintenance limit: IN $\geq 0.09\text{mm}$,

EX $\geq 0.10\text{mm}$.

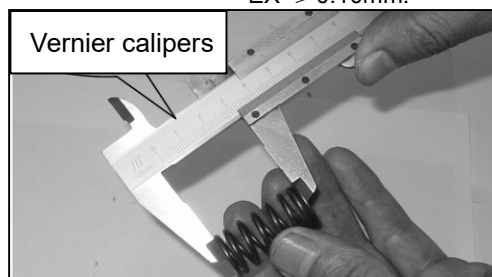

Cylinder

To remove the cylinder:

1. Remove the cylinder head cover (See Removal of cylinder head cover)
2. Remove the camshaft (See Removal of camshaft);
3. Remove the cylinder head (See Removal of cylinder head)
4. Remove the chain slide;
5. Remove cylinder connecting bolt
6. Remove the tensioner
7. Remove the cylinder; remove the cylinder gasket.

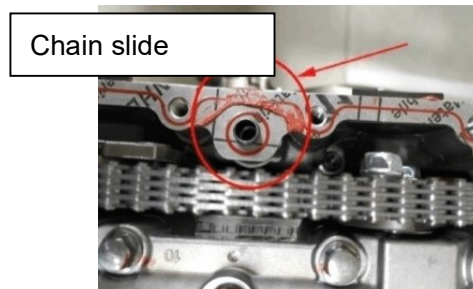

⚠ Notice:

Do not drop the location pin into the crankcase.

Do not bruise the cylinder wall.

To mount the cylinder :

Installation is in the reverse order of removal. Precautions for installation:

1. Confirm the location pin; clean all parts and components, and check whether the cylinder oil through is unobstructed, clean and free of leak
2. Replace a new cylinder gasket, and confirm the notch direction of the piston ring; mount the cylinder after fastening the piston with the piston slide gage seat

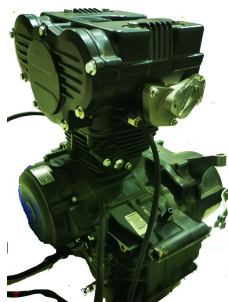

Cylinder inspection

Check the cylinder for abrasion or damage, and check the cylinder wall for scratch.

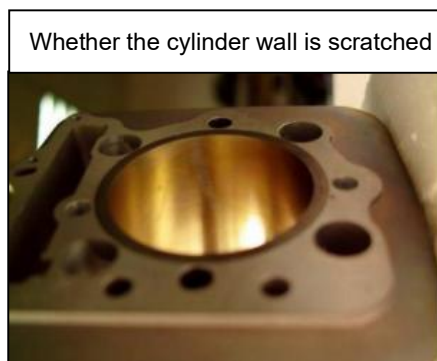

Check the cylinder wall for deformation, and use the edge ruler and clearance gauge to inspect the planeness of the cylinder's joining surface.

Maintenance limit: $\leq 0.05\text{mm}$.

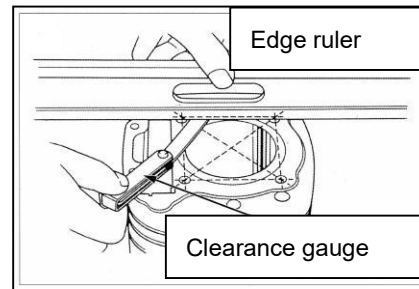

Measure the cylinder internal diameter. The measurement shall be made at three positions: top, middle and bottom, measure in two crossing directions for each position, and finally calculate their mean value.

Maintenance limit: $\leq \phi 85.10\text{mm}$

Work out the Cylinder's grade slope.

Maintenance limit: $\leq 0.05\text{mm}$

Work out the Cylinder's roundness.

Maintenance limit: $\leq 0.05\text{mm}$

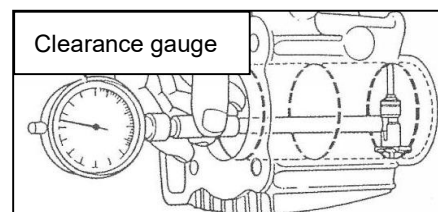

Piston

To remove the piston:

1. Remove the cylinder head cover (See Removal of cylinder head cover)
2. Remove the camshaft (See Removal of camshaft).
3. Remove the cylinder head (See Removal of cylinder head).
4. Remove the cylinder (See Removal of cylinder)
5. Remove the piston pin retainer at one side, and pull out the piston pin.
6. Take out the piston.

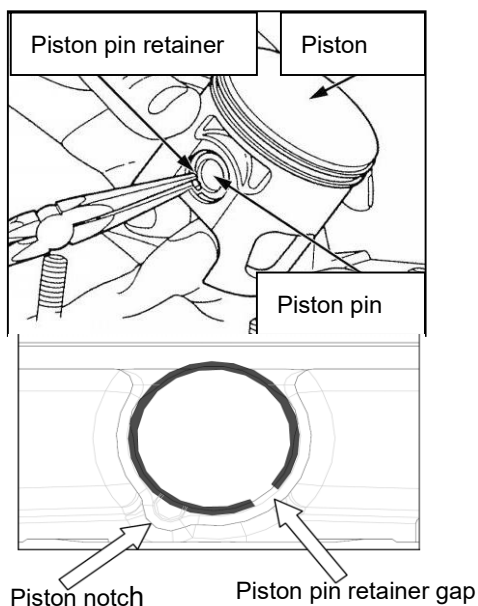

⚠ Notice:

Do not drop the piston pin retainer into the crankcase.

To mount the piston pin:

1. Coat engine oil on the piston pin surface and let the oil go through the piston and the small end bore of the crankshaft link rod.
2. Mount the new piston pin retainer, with the gap staggering the piston gap by more than 15° as shown in the above.
3. Mount the cylinder (See Installation of cylinder).
4. Mount the cylinder head (See Installation of cylinder head);
5. Mount the camshaft (See Installation of camshaft).
6. Mount the cylinder head cover (See Installation of cylinder head cover).
7. cylinder head cover).

⚠ Notice:

Do not damage the piston pin and piston ring.

Do not reverse the mounting position of the first ring (ATG marker) and second ring (A marker).

⚠ Notice:

Assemble the piston with the top side with the marker “O” facing exhaust side.

Do not drop the piston pin retainer into the crankcase.

Disassembly and assembly of piston:

Disassemble and assemble piston according to the following diagram.

While assembling, let the side with marker face the top of piston; if the marker can not be clearly identified, judge according to the shape of the piston ring (as shown in the figure below). Stagger the piston ring gap by more than 120°

While assembling the oil ring, mount the corrugated ring first, then mount the lip rings at both sides, with the corrugated ring joint staggering with both lip rings by 90°, and with the two lip rings staggering with each other by 180°

The piston pin retainer shall be replaced with new one while assembling after disassembling, and stagger the gap and the piston notch by more than 15°.

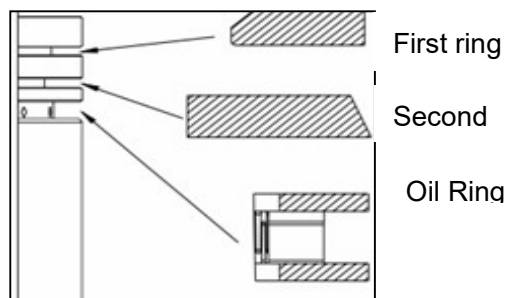

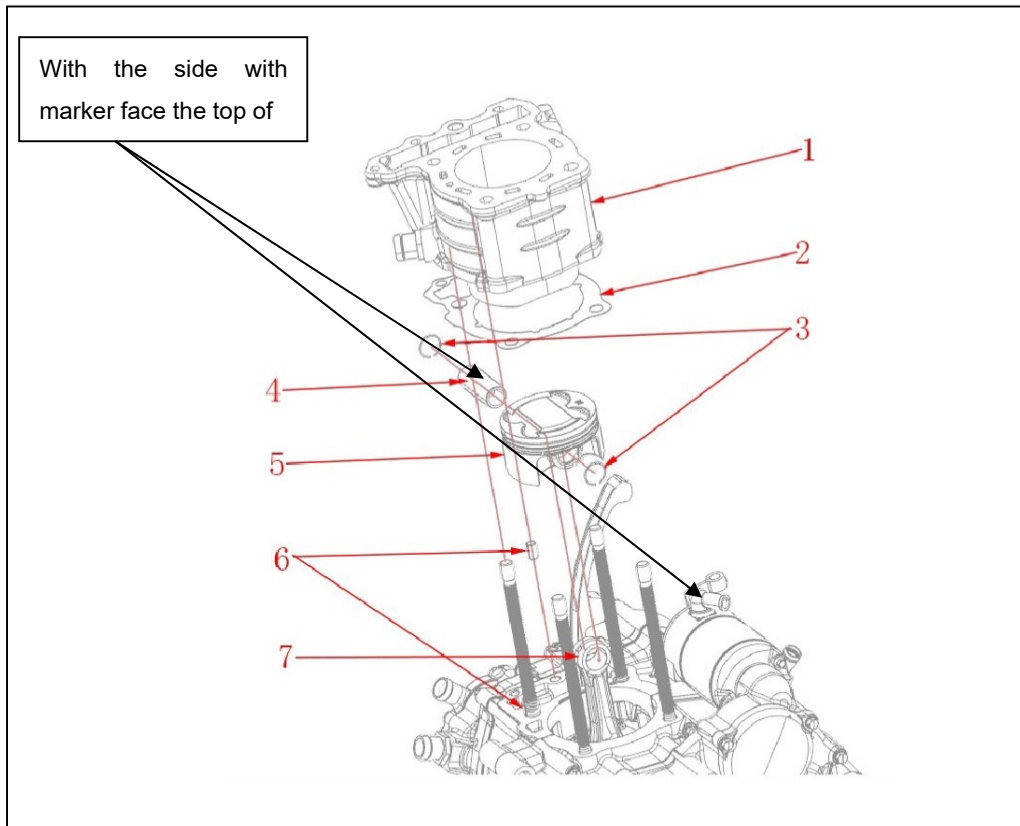

No	Procedure	Quantity	Remarks
	Sequence of disassembling		Assembling is in the reverse order of disassembling.
1	Crank rod assembly	1	
2	Crank and Box gasket	1	The retaining ring must be fully fitted into the groove
3	Piston pin collar	2	
4	Piston pin	1	
5	Piston	2	
6	Φ8×14 hollow locating pins	1	
	Locating Pin 12×20	1	The locating pin is not disassembled
7	Connecting Rod	1	

Piston inspection

Check the piston for abrasion or damage, cracks, etc. and check the skirt section for scratch.

Measure the piston external diameter at the position 10mm above the piston skirt.

Maintenance limit: $\geq \phi 84.87\text{mm}$

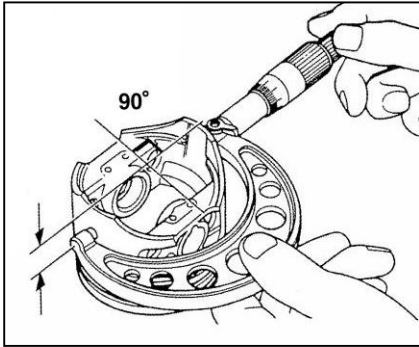

Measure the piston pin external diameter.

Clearance gauge

Maintenance limit: $\geq \phi 19.98\text{mm}$

Work out the clearance between the cylinder and piston.

Maintenance limit: $\leq 0.10\text{mm}$.

Work out the clearance between the piston and piston pin.

Maintenance limit: $\leq 0.07\text{mm}$.

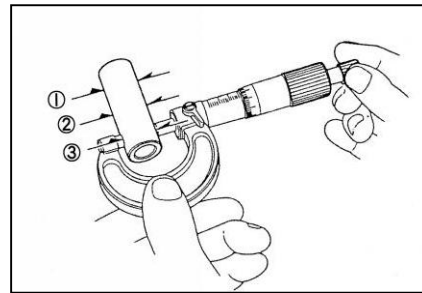

Measure the piston pin hole inside diameter.

Maintenance limit: $\leq \phi 20.05\text{mm}$.

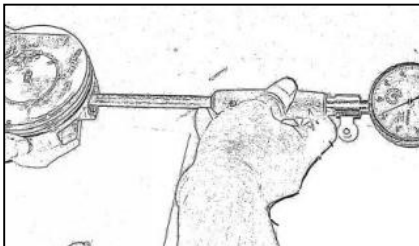

Measure the clearance between the piston ring and the piston groove before removing the piston ring.

Maintenance limit: First ring / Second ring $\leq 0.12\text{mm}$, Oil ring $\leq 0.40\text{mm}$.

Mount the piston rings into the cylinder respectively and measure the gap clearance. Maintenance limit: First ring $\leq 0.65\text{mm}$, Second spring $\leq 0.7\text{mm}$.

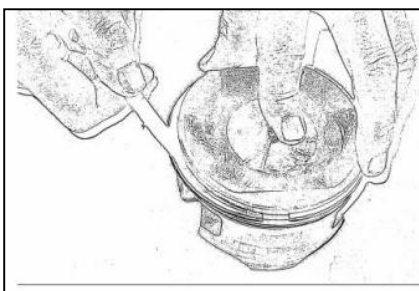

Clutch and Right crankcase cover

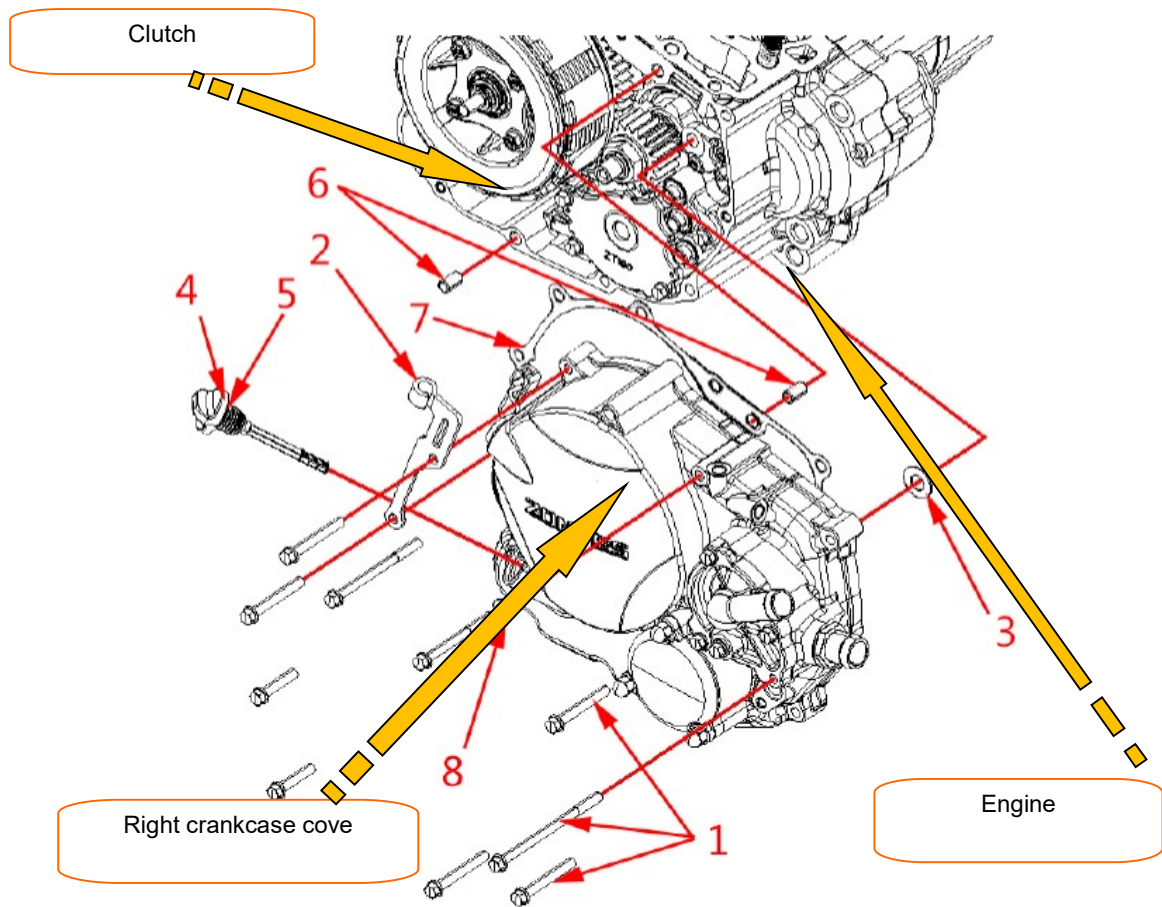

Clutch and Right crankcase cover

Maintenance notice	Clutch
Troubleshooting	Right crankcase cover

Maintenance notice

To carry out the maintenance stated herein, it is unnecessary to detach the engine from the frame. However, the engine lubricating oil must be discharged.

Remove the protecting shield, and loosen the rear brake cylinder body, rear brake lamp switch and spring and rear brake return spring, and then pull out the rear brake pedal.

Before assembling, clean all parts and components with cleaning agent and dry them with compressed air.

To assemble the clutch, loosen the clutch spring and coat engine oil on the clutch disc; in case of replacing new clutch, the clutch disc must be soaked in oil for over 24 hours before being assembled.

Be careful not to damage the crankshaft seal on the right crankcase cover.

Technical specifications & maintenance benchmark

	Item	Standard value	Maintenance limit value
Clutch	Handle free stroke	10~20	/
	Spring free length	39.74	38.7
	Disc thickness	3.0	2.8
	Disc planeness	/	/
	Clutch plate thickness	1.4	/
	Clutch plate planeness	0.10	0.20

Key torque values

Clutch retaining nut	114-126N.m
Primary driving gear fastening nut	143-157N.m
Clutch lift plate fastening nut	8-12N.m

Troubleshooting

- **Clutch**

In case of clutch operation failure, a better correction may usually achieved by adjusting the clutch handle free stroke.

- **Clutch slipping while accelerating**

- 1) Insufficient free stroke;
- 2) Clutch disc abrasion;
- 3) Clutch plate deformed or bent;
- 4) Clutch spring failure.

- **Excessive handle pressure**

- 1) Clutch cable galling, damaged or dirty;
- 2) Clutch push rod damaged or jammed.

- **Hard clutch operation**

There is burr on clutch housing chute.

- **Shift lever can't return**

- 1) Return spring cracked or slipped;
- 2) Transmission shaft plate convenes with crankcase or crankcase cover.

- **Vehicle moves slowly upon firmly grabbing the handle**

- 1) Excessive handle free stroke
- 2) Clutch plate deformed or bent.

- **Hard shifting or impossible to shift**

- 1) Locating plate bent;
- 2) Stopping plate assembly damaged or cracked;
- 3) Shifting yoke cracked or slipped;
- 4) Clutch improperly adjusted.

Right crankcase cover

To remove the cylinder head cover:

1. Remove the oil drain plug to drain the engine oil inside the crankcase.



Waste engine oil flow into the oil

2. Separate the clutch control line with the clutch operating lever



Clutch operating lever

3. Remove the oil filter cover.
4. Remove the right crankcase cover connecting bolt
5. Take out the right crankcase cover component.
6. Take out the right crankcase cover sealing paper gasket

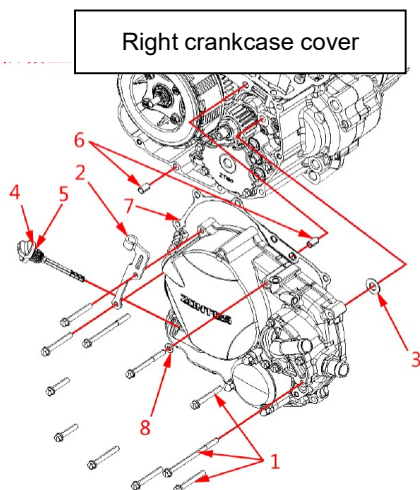

To install the right crankcase cover:

1. Confirm the location pin; clean up the residual sealing paper gaskets on the right crankcase and right crankcase cover.
2. Replace with a new right crankcase cover sealing paper gasket.



Clean up the seal surface

3. Mount the right crankcase cover.
4. Mount the oil filter cover.

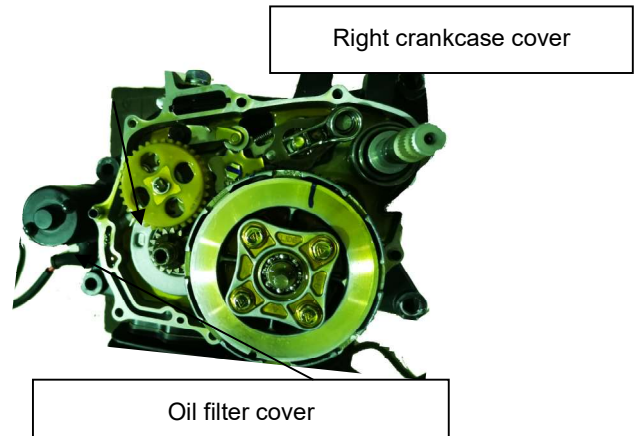

5. Adjust the direction of the clutch operating lever,
Mount the clutch operating lever, rear brake return
spring, cotter pin, rear brake lamp switch, etc.



6. Refill engine oil.



⚠ Notice:

Do not scrape the crankshaft oil seal.

**Assemble only when the rack side of the clutch
push rod faces the crankshaft.**

Disassemble and assemble of right crankcase cover

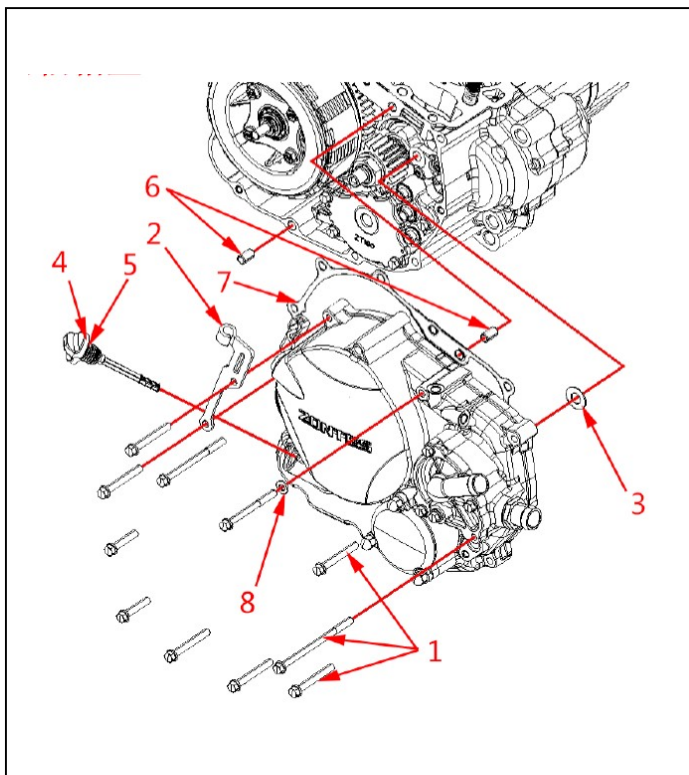

No	Procedure	Quantity	Remarks
	Removing order		Installation is in the reverse order of removal
1	M6×30 Hexagon flange face bolt	2	
	M6×45 Hexagon flange face bolt	6	
	M6×60 Hexagon flange face bolt	1	
	M6×75 Hexagon flange face bolt	1	
	M6×90 Hexagon flange face bolt	1	
2	Clutch stay bracket	1	
3	10.2×21×1 Thrust washer	1	
4	Oil Rule	1	
5	15×3.1 ACRYLATE o-ring	1	
6	Φ8×14 Hollow Locating Pin	1	
7	Right crankcase cover gasket	2	
8	6.3×12×1.6 Copper gasket	1	

Clutch

To remove the clutch:

1. Remove the right crankcase cover (See "Removal of right crankcase cover").

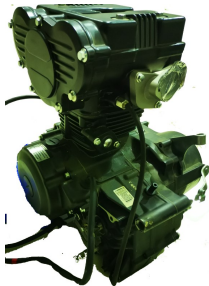

2. Remove the clutch push rod with the clutch push rod extractor **S TOOL**.

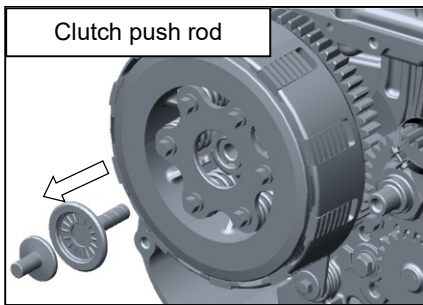

3. Use the fastening tool **S TOOL** to clamp the primary driving and driven gear, and remove the nut M18 and butterfly washer.

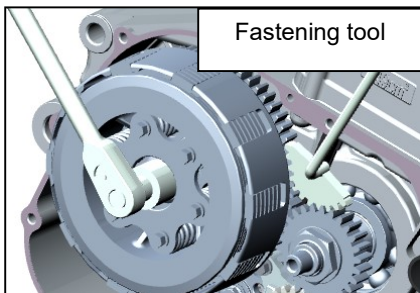

4. Remove the clutch.
5. Remove the clutch washer.

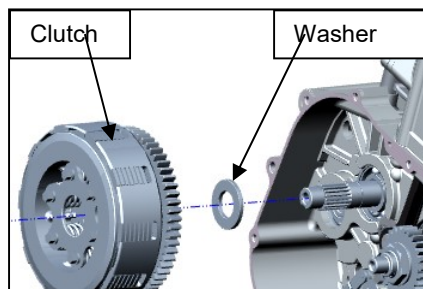

To install the clutch:

1. Mount the clutch washer with the sabotage side facing the main shaft right bearing.
2. Mount the clutch.

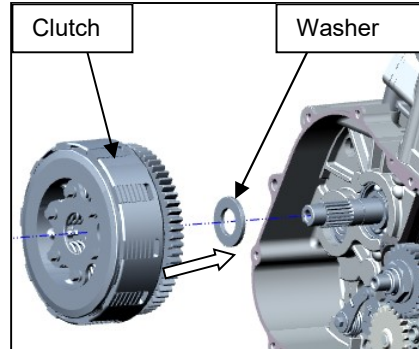

3. Mount the butterfly washer and retaining nut M18. Note to assemble with the protruding side of the butterfly nut washer facing outside.

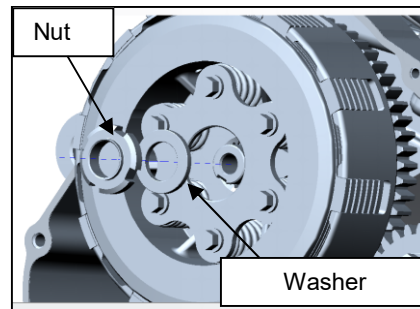

4. Use the fastening tool **S TOOL** to clamp the primary driving and driven gear, and screw up the retaining nut M18 to the tightening torque of 120N.m.

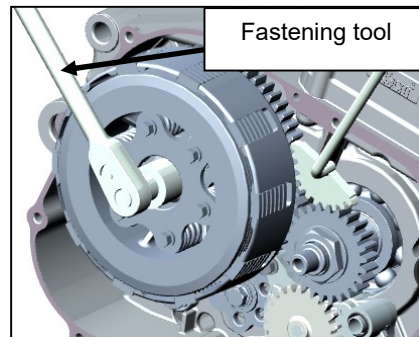

5. Mount the clutch push rod with the clutch push rod

assembler 



6. Assemble the right crankcase cover by turning the clutch push rod until its rack side faces the crankshaft. (See "Installation of right crankcase cover").



Right crankcase cover

 **Warning**

Thread retaining adhesive LOCTITE243 must be coated on the clutch retaining nut M18 while assembling, with the tightening torque being 120N.m.

Removal / Installation of Clutch

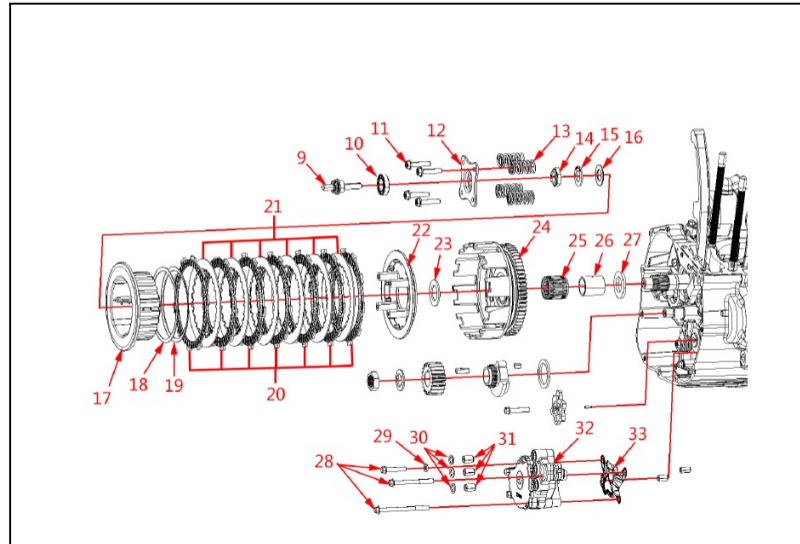

No	Procedure	Quantity	Remarks
	Removing order		Installation is in the reverse order of removal
9	Clutch Release Mandril Sleeve Assembly	1	Tightening torque 12N.m.
10	GB276-61903 Deep groove ball bearing	1	12N.m±1.5N.m
11	M6×30 Hexagon thin nut	4	
12	Clutch lifting plate	1	
13	Clutch Spring	1	108N.m±1.5N.m
14	M16×1 Hexagon thin nut	1	
15	16.2×28×2.4×2 Release Washer	1	
16	16.2×3.2×1 Thrust washer	1	
17	Clutch Plate	1	
18	96.3×101×3 Thrust washer	1	Assemble with the sub stage side facing inwards
19	96.5×107×2.2×1 Release Washer	1	
20	Clutch spring	6	
21	125×2.5 Clutch plate	1	
22	Clutch pressure plate	1	
23	16.2×37×2 Thrust washer	1	
24	Clutch active disc assembly	1	
25	K27×27×29.3 Needle roller bearing	1	
26	Clutch bushing	1	
27	Clutch bushing backing	1	
28	M6×30 Hexagon flange face boltt	1	12N.m±1.5N.m
29	6.3×12×1.6 Copper gasket	1	
30	9.8×2.5 ACRYLATE	3	
31	Φ 10×14 Hollow Locating Pin	3	
32	Oil Pump subassembly	1	
33	Oil Pump cushion	1	

Disassemble and assemble of clutch

Disassemble and assemble the clutch according to the following diagram.

While removing the clutch lift plate, alternatively loosen the 6 connecting bolts to avoid damage of cracking due to uneven force of the clutch spring.

While mounting the clutch lift plate, alternatively loosen the 6 connecting bolts to the specified torque. Assemble with the protruding side of the butterfly washer facing the plain washer

While assembling, the clutch disc must be coated with lubricating oil; in case of replacing new clutch disc, it must be soaked in oil for over 24 hours before being assembled. Do not further disassemble the clutch housing, otherwise damage will occur.

Explanation:

While unscrewing bolt, do it in a crossing way twice or thrice. Do in the same way for screwing up bolt.

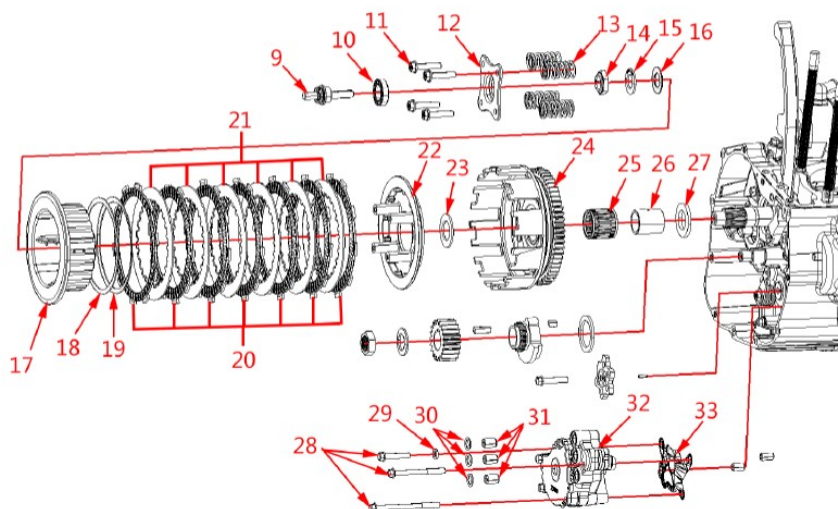

No	Procedure	Quantity	Remarks
	Removing order		Installation is in the reverse order of removal
34	Φ 10×14 Hollow Locating Pin	2	Tightening torque 12N.m.
35	M18×1 Hexagon thin nut	1	
36	18.2×30×2.5×2 Lock Washer	1	
37	Primary drive gear	1	
38	5×5.5×19.2 Ordinary flat key	1	Gum base, soaking oil while assembling
39	Reconfiguring timing drive sprocket	1	
40	5×5.5×26×9 Semicircle key	1	
41	Limit Ring of crankshaft right bearing	1	
42	M6×30 Hexagon flange face bolt	1	12N.m±1.5N.m
43	Shift Star Cam	4	Assemble with the sub stage side facing inwards
44	Cylindrical Pin	1	

Clutch inspection

1. Check whether the housing spline has scars or cuts

due to the collision of clutch disc.

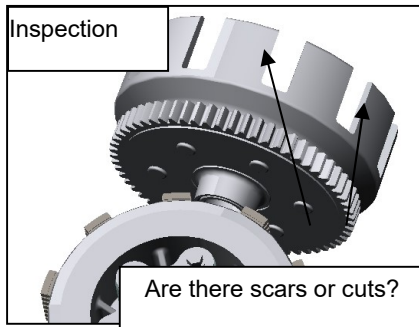

2. Check the clutch disc. If there is a scratch or de pigment or a strong scorching smell, replace it.

Measure the thickness of each clutch disc.

Maintenance limit: $\geq 2.8\text{mm}$.

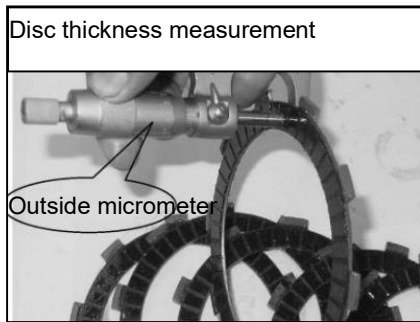

3. Check the clutch plate for distortion, and check the planners with a clearance gauge.

Maintenance limit: $\leq 0.20\text{mm}$.

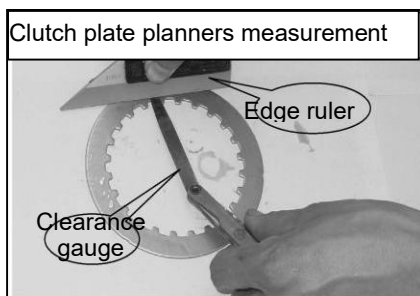

4. Measure the thickness of each clutch plate. The thickness is 1.4mm.

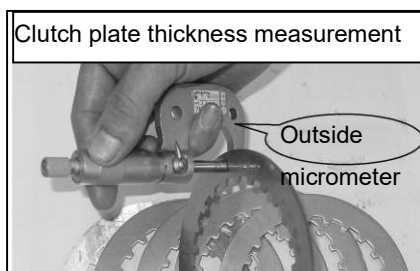

5. Measure the free length of the clutch spring.

Maintenance limit: $\geq 41.3\text{mm}$.

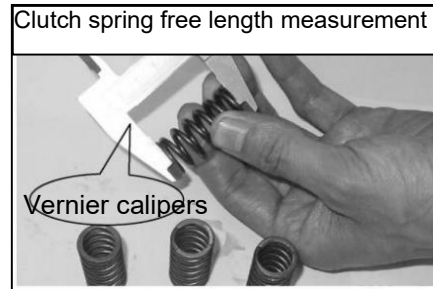

8、Magneto and starting system

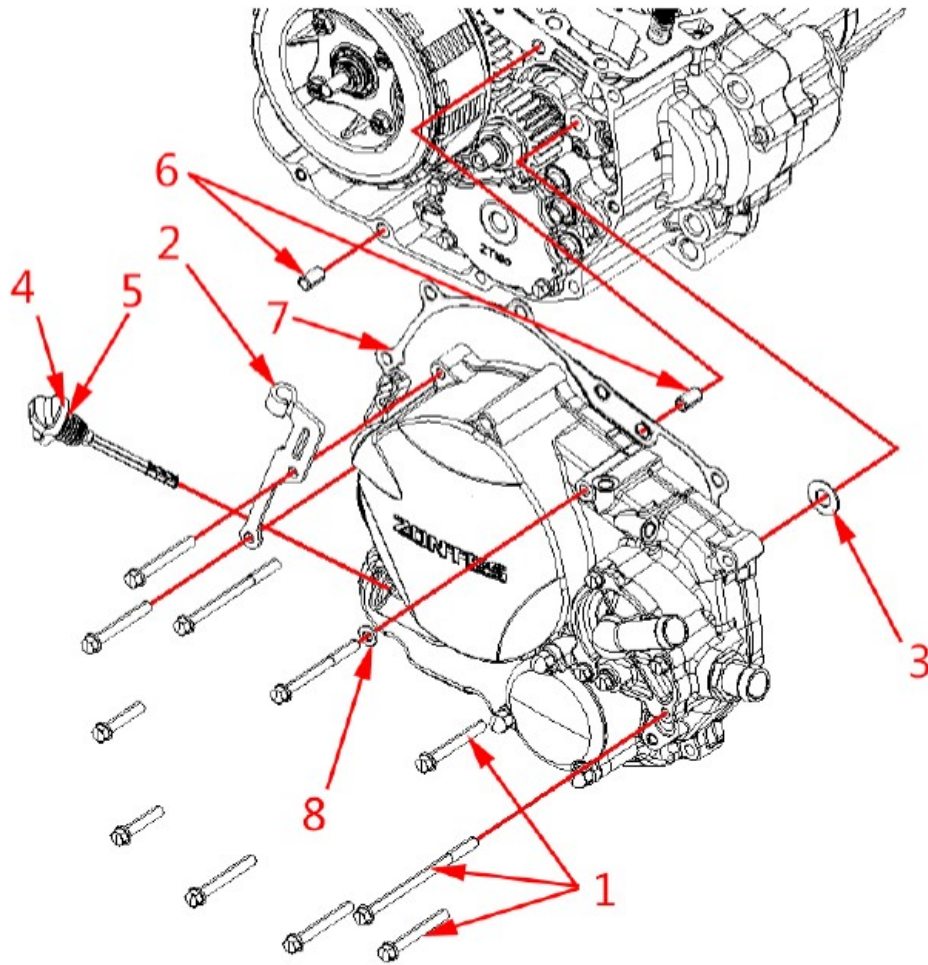

Magneto and starting system

Maintenance notice	Rotor assembly
Left front cover	Starting motor and starting transmission system

Maintenance notice

To carry out the maintenance stated herein, and the engine lubricating oil must be drained.。

Before assembling, clean all parts and components with cleaning agent and dry them with compressed air.

When mount, Mount the parts, coat the mixture of engine oil and molybdenum disulfide onto the left crank journal, as the initial lubrication.。

Do not dent the seal surface, and do not damage the stator coil.

Technical specifications & maintenance benchmark

Item		Standard value	Maintenance limit value
Disk gear	Disk gear external diameter	$\phi 51.67 \sim \phi 51.7$	$\phi 51.57$
One-way device outer body	One-way device outer body internal diameter	$\phi 35 \sim \phi 35.027$	$\phi 35.040$
Disk gear washer	Washer thickness	5.65~5.75	5.6

Key torque values

Rotor fastening nut	36~45N.m
Stator fastening bolt	8-12N.m
Pressure plate fastening bolt	7~10N.m
Starting clutch connecting screw	8~12N.m

Left front cover

To remove the left front cover:

1. Remove the gear shift pedal and left rear cover, and separate the magneto lead connector with the main cable.



2. Unscrew the oil drain plug to drain the engine lubricating oil inside the engine



3. Remove the double-linked gear cover connecting bolts
4. Remove the left front cover.

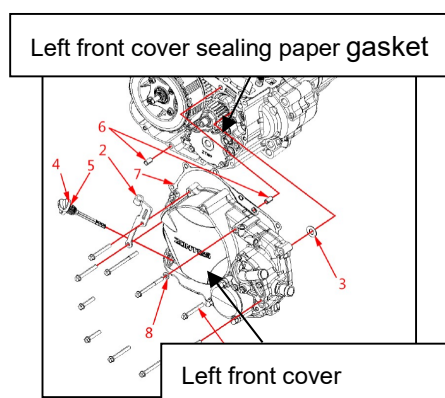

Disassembly and assembly of left front cover

Disassemble and assemble the left front cover according to the following diagram.

Use the thread retaining adhesive LOCTITE 648 while assembling the pressure plate bolt.

Use the thread retaining adhesive LOCTITE 648 while assembling the magneto stator connecting bolt.

○ In case of O-ring aging, prolonging or deforming, replace it.

 **Notice:**

Do not dent the seal surface, and do not damage the stator coil.

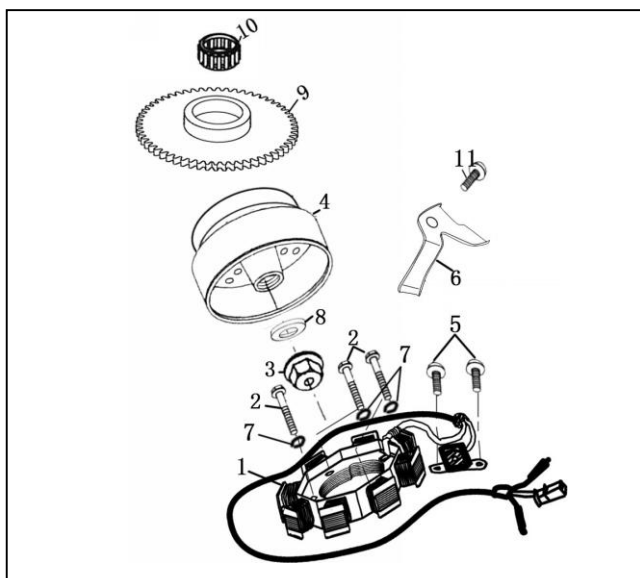

No	Procedure	Quantity	Remarks
	Removing order		Installation is in the reverse order of removal
1	stator module	1	
2	Bolt M5*27	1	Replace it with a new one as required
3	Nut M14*1.25	1	
4	rotor assembly	1	
5	Bolt M6x16	1	
6	Magneto clamp	1	
7	lightened spring washer	1	
8	flat washer	1	
9	disc gear cutter	1	
10	needle bearing	1	
11	Bolt M6*12	1	

Rotor assembly

To remove the clutch:

1. Remove the left front cover (See Removal of left front cover).
2. Remove the starting idle gear, double-linked gear, etc

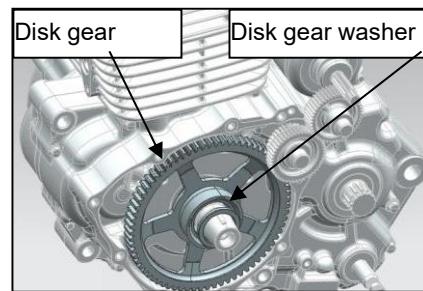
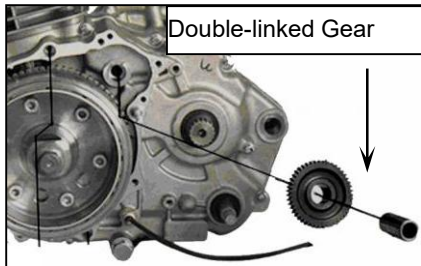

Notice:

Do not let the semicircular key drop into the crankcase.

3. Use the rotor fastening tool  to fasten the rotor, and remove the fastening nut M12 and plain washer.

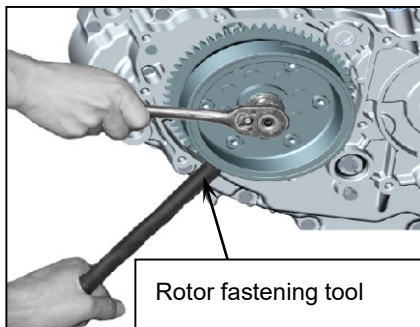

4. Use the rotor extractor  to extract the rotor..

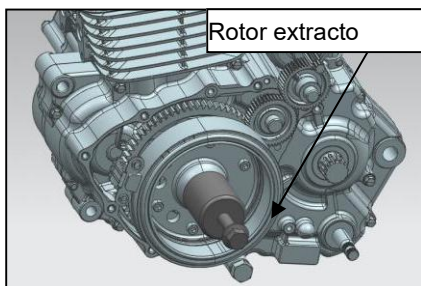

5. Remove the rotor assembly washer, disk gear, needle bearing, disk gear washer

Disassembly and assembly of rotor assembly

Disassemble and assemble the rotor assembly according to the following diagram.

Use thread retaining adhesive LOCTITE 648 on the screw while assembling, with the tightening torque being 10-14N.m

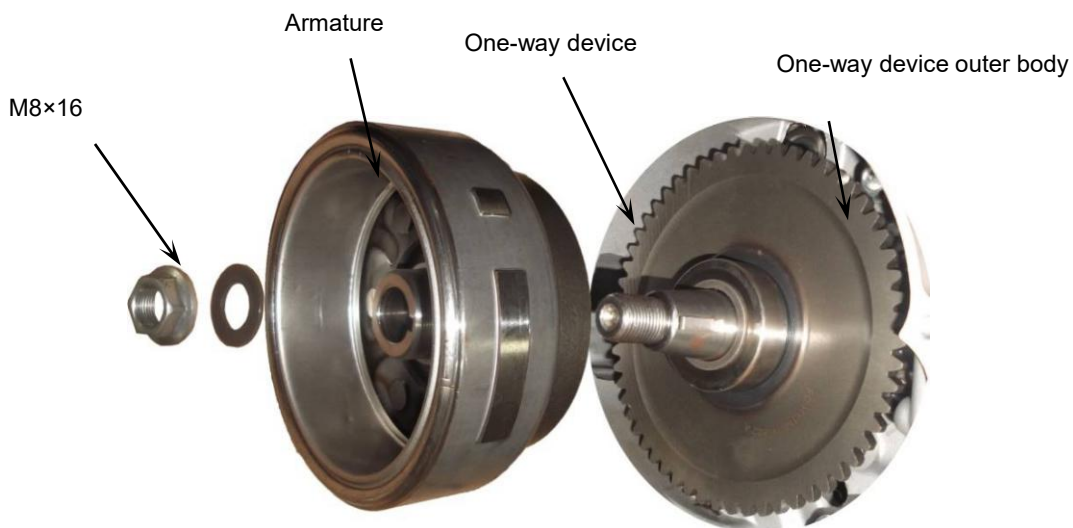

No	Procedure	Quantity	Remarks
	Removing order		Installation is in the reverse order of removal
1	Screw M8×16	6	Use thread retaining adhesive LOCTITE 648 while assembling, with the tightening torque being 25N.m
2	One-way device outer body	1	
3	One-way device	1	Be careful of the assembling direction
4	Armature	1	

Starting motor and starting

Transmission system

1. Remove the live wire and earth wire of the starting motor.
2. Remove the starting motor connecting bolt M6×25.
3. Push the motor towards the right and lift it, and then carefully take it out from the left side.

Take it out from the left

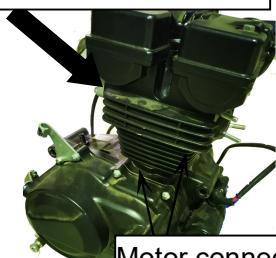

Motor connecting bolt

Installation is in the reverse order of removal

To mount the rotor assembly:

1. Mount the disk gear washer, coat the mixture of engine oil and molybdenum disulfide onto the left crank journal, and mount the disk gear and confirm the semicircular key.

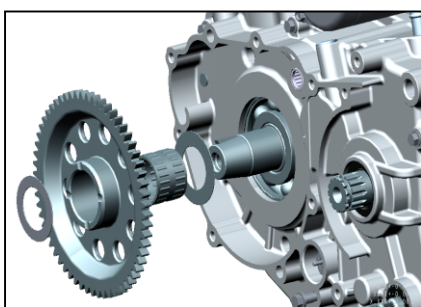

Apply the mixture of engine oil and molybdenum disulfide

2. Mount the rotor assembly

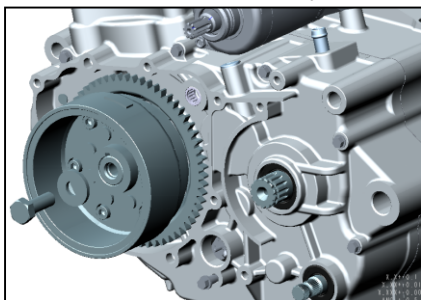

3. Mount the plain washer and apply thread retaining adhesive LOCTITE648 to the fastening nut M12; use the rotor fastening tool  to fasten the rotor, and screw up the nut M12 to the torque of 45N.m

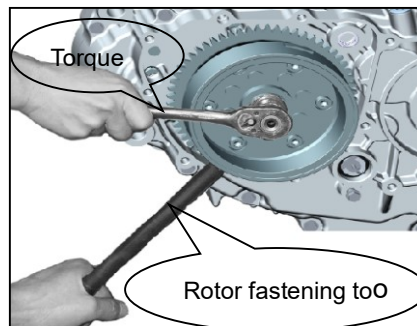

4. To install the double-linked gear:

The Washer and the double-linked gear is assembled into the left crankcase

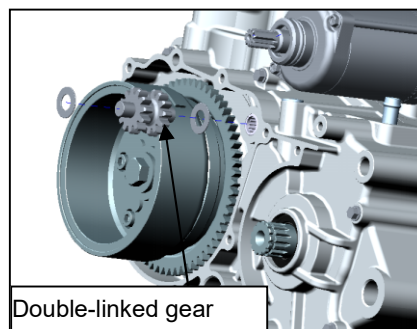

5. To install the left front cover:

(1)Clean the sealing paper gasket remaining on the left crankcase and left front cover, replace with new left front cover sealing paper gasket and confirm the location pin, starting idle gear, double-linked gear, etc. are in correct position.

(2)Mount the left front cover,

(3)Mount the left front cover bolt

(4) Connect the magneto leads.

(5) Mount the left rear cover, gear shift pedal and engine

protection plate.

(6) Put on the oil drain plug and refill engine lubricating oil.

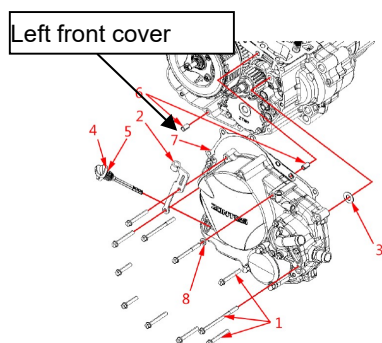

6. To install the double-linked gear cover:

- (1) Clean up the left front cover and parts, mount the starting idle gear, double-linked gear, etc.
- (2) The O-ring into the double gear cover, O In case of O-ring aging, prolonging or deforming, replace it.
- (3) Mount the double-linked gear cover,
- (4) screw up to the torque of 8-12N.m

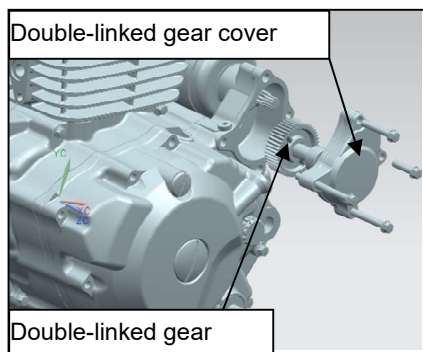

⚠ Notice:

Never let adhere to the left crank conical surface and rotor tapered surface.

The disk gear shall only be capable of rotating clockwise flexibly relative to the rotor.

Use the thread retaining adhesive LOCTITE 648 while assembling the pressure plate bolt.

⚠ Warning

Thread retaining adhesive LOCTITE243 must be applied to the rotor retaining nut M12 while assembling, with the tightening torque being 45N.m.

Check

- 1、 Check the spline gear of output shaft of the starting motor for defect, squeezing, deforming, etc.
- 2、 Check the idle gear and double-linked gear for missing teeth, etc.



- 3、 Check the idle gear shaft and double-linked gear shaft for bending.

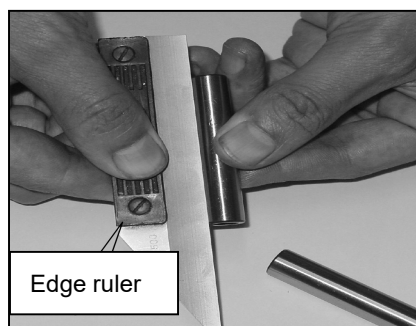

- 4、 Check the rotating flexibility and unidirectivity of the disk gear (relative to clockwise rotor rotation).

- 5、 Check the axial play of the disk gear, generally not less than 0.4mm.

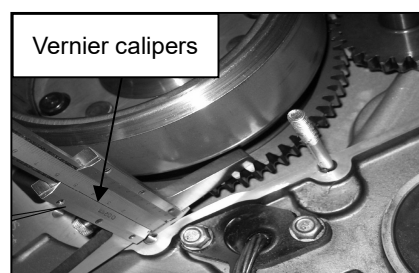

6. Measure the disk gear diameter, the maintenance

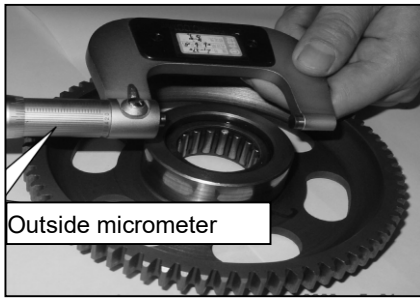

7. Measure the washer thickness, the maintenance limit:

$\geq 0.4\text{mm}$

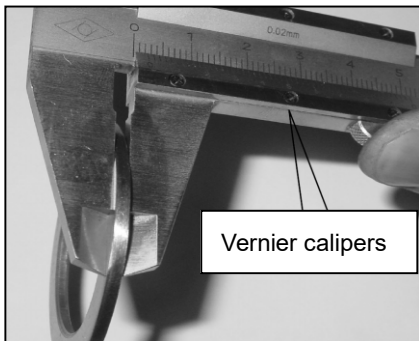

9、Crankcase, crankshaft and Shift mechanism

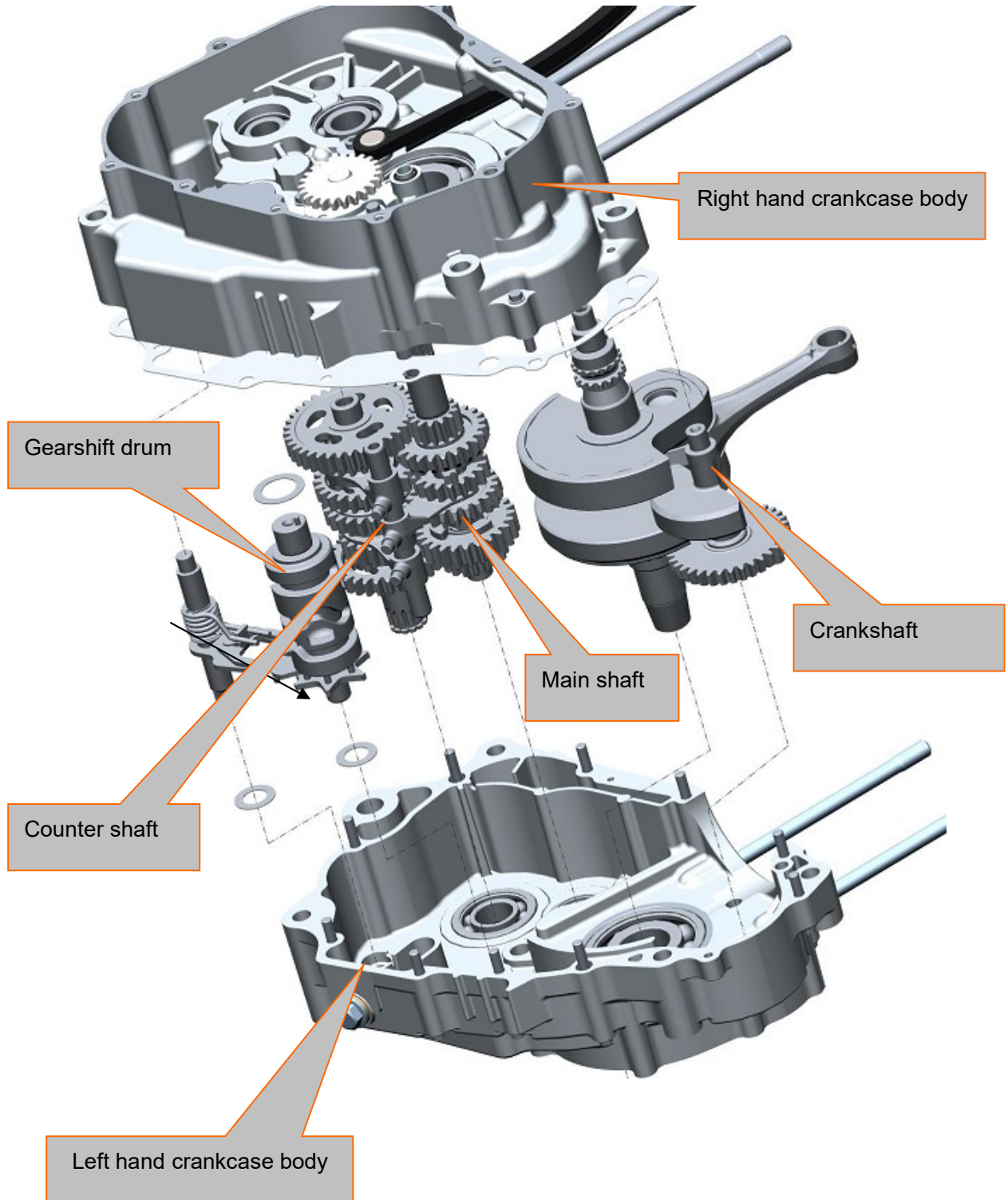

Crankcase, crankshaft and Shift mechanism

Maintenance notice	Crankshaft and balance shaft
Troubleshooting	Variable transmission system
Crankcase	

Maintenance notice

To carry out the maintenance stated herein, the engine must be removed from the frame.

To repair the crankshaft, balance shaft or variable transmission system, the left hand crankcase and the right hand crankcase must be separated, which is known as crankcase dissection. Before crankcase dissecting, the following parts and components of the engine shall be removed:

- 1 Right hand crankcase, clutch, gear shifter
- 2 Cylinder head cover, camshaft, cylinder head, cylinder and piston (See “Cylinder head, cylinder and piston”);
- 3 Left front cover, rotor assembly, electrical starting transmission system (See “Magneto and electrical starting system”);
- 4 Driving drive sprocket, shift switch.

Before assembling, clean all parts and components with cleaning agent and dry them with compressed air.

Technical specifications & maintenance benchmark

Item		Standard value	Maintenance limit value
Shift fork claw thickness	Gear shift fork	6.05~5.40	5.80
	Connecting rod small end bore diameter	$\Phi 20.03 \sim \Phi 20.038$	$\Phi 20.063$
Crankshaft	Disc planeness	0.028~0.042	0.06
	Connecting rod big end radial clearance	0.30~0.60	0.80
	Radial runout	0.03	0.10
	Left crank journal	$\Phi 29.959 \sim \Phi 29.98$	$\Phi 29.87$

Troubleshooting

● Noise from engine

1. Crankshaft bearing worn;
2. Connecting rod big end bearing worn;
3. Driving/driven shaft bearings worn;
4. Balance shaft supplementary tooth spring failure.

● Driving/driven shaft gears engaged badly

1. Shift fork bent or damaged;
2. Shift fork shaft bent;
3. Gearshift drum badly machined or bearing shifted;
4. Driving/driven shaft bearings shifted.

● Gear shift trouble

1. Shift fork bent or damaged;
2. Shift fork shaft bent;
3. Gearshift drum guiding slot worn or damaged;
4. Clutch improperly adjusted.
5. Locking plate bend or fray;
6. Five star plate assy broken
7. Pin broken or slip off

● Gear shaft cannot return back

1. Spring broken or slip off
2. Variable-speed shaft plate interfere crankcase or crankcase cover

Crankcase

To remove the crankcase:

1. Remove the engine from the frame (engine oil fully drained) and put it on the assembly operating table.
2. Remove such parts and components as right hand crankcase cover, clutch, gear shifter, cylinder head cover, camshaft, cylinder head, cylinder, piston, left front cover, rotor assembly, electrical starting transmission system, driving drive sprocket, etc.
(Refer to the related sections).

Remove the mould closing bolt



3. Use a bakelite hammer or a nylon hammer to strike the left hand crankcase gently to separate it with the right hand crankcase.
4. Remove the driving/driven shaft, gearshift drum, shift fork, etc.
5. Remove the cranks-haft and balance shaft.

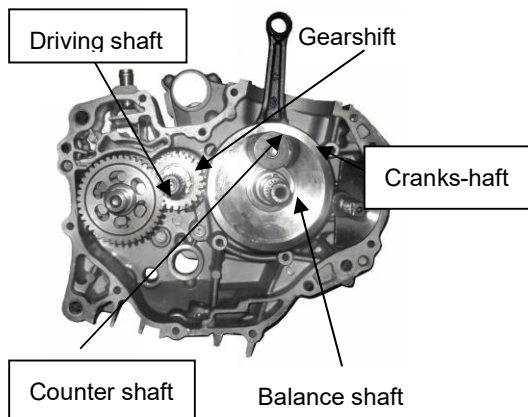

⚠ Notice

Do not pry the left/right hand crankcase body by inserting such tools as screwdrivers into the mould closing face.

To mount the crankcase:

1. Place the right hand crankcase on the assembly operating table, and assemble the internal parts and components of the crankcase, including crankshaft, balance shaft, driving/driven shaft, gearshift drum, shift fork, etc
2. Clean up the left and right crankcase box surface, put the new crankcase paper pad, confirm the positioning pin.



Crankshaft box paper pad

3. Use the counter shaft oil seal guide **S TOOL** to protect the counter shaft oil seal, use the gearshift drum oil seal guide **S TOOL** to protect the gearshift drum oil seal, and mount the left hand crankcase (closing).

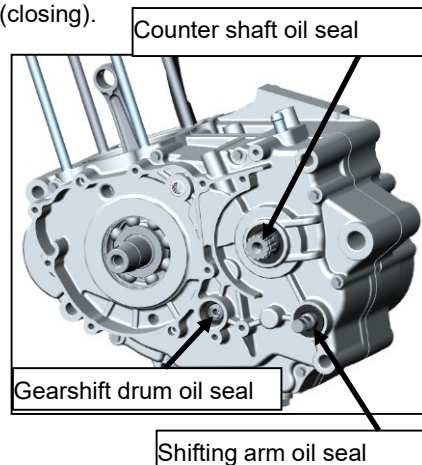

4. Mount the mould closing bolt and tighten it.

5. Mount other parts and components of engine, mainly include right hand crankcase cover, clutch, gear shifter, cylinder head cover, camshaft, cylinder head, cylinder, piston, left front cover, rotor assembly, electrical starting transmission system, driving drive sprocket, etc. (Refer to the related sections).
6. Mount the assembled engine onto the frame, and engine oil to complete the assembly of the complete vehicle.

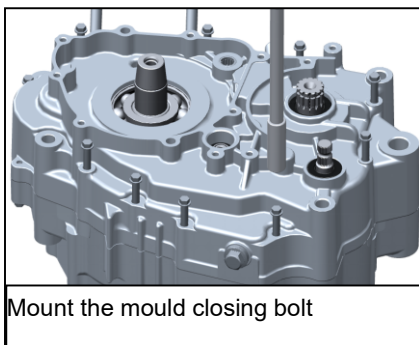

⚠Notice:

To close the crankcase, use your hand(s) to gently press it in place, or use a Bakelite hammer to strike it gently. Never strike it forcibly.

Removal and installation of crankcase

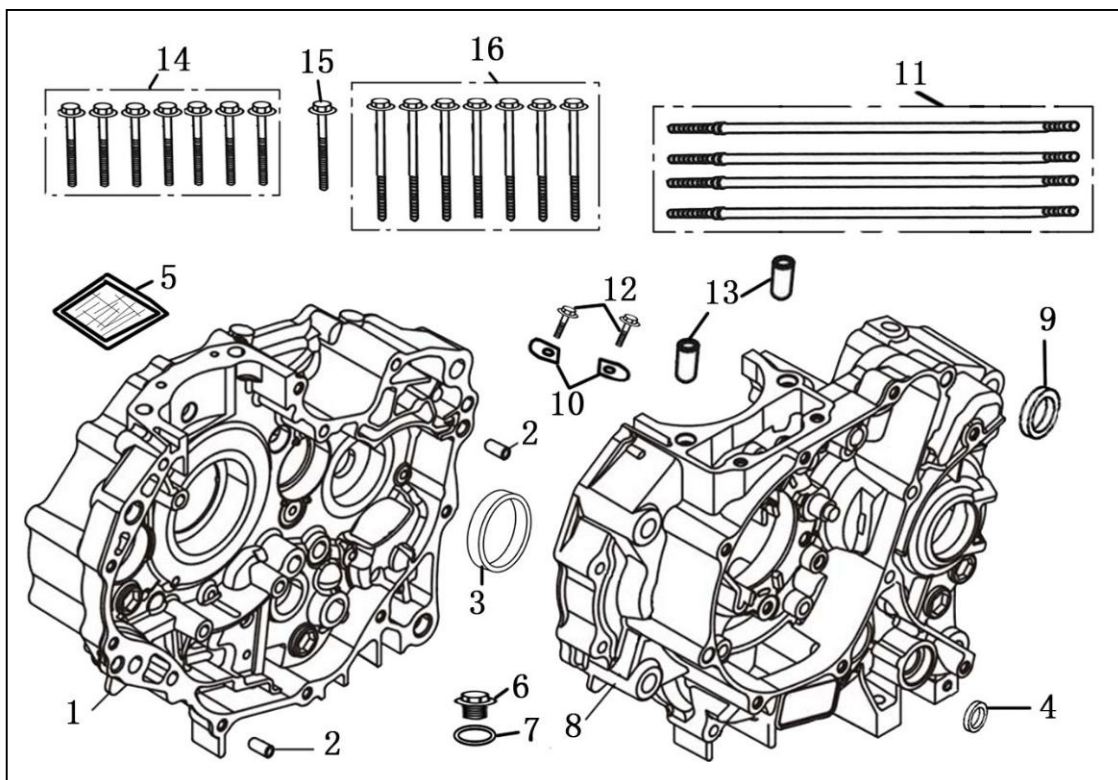

No.	Procedure	Quantity	Remarks
	Removing order		Installation is in the reverse order of removal
1	Right hand crankcase	1	
2	Pin	1	
3	Pad	1	
4	O-ring	1	
5	engine oil filter net	1	
6	Release oil bolt	1	
7	Pad	1	
8	Left hand crankcase	1	
9	O-ring	1	
10	Double head bolt	1	
11	Main gear plate	1	
12	Bolt M6*16	1	
13	Pin 10*14	2	
14	BOLT,FLG M6*40	7	
15	BOLT,FLG M6*45	1	
16	BOLT,FLG M6*70	7	

Disassembly and assembly of left hand crankcase

Disassemble and assemble the left hand crankcase according to the following diagram.

Do not remove breather pipe joint, otherwise damage will be caused. Generally, do not remove the bearing; if it is removed, coat engine oil on surfaces of spare parts while pressing it in; mount it with SST and confirm the press-in depth of the bearing.

Assemble the driving shaft bearing with the with oil seal facing inwards. Disassembling the needle bearing may damage it; in case it is damaged, always change a new one. Replace oil seal with a new one after being removed.

⚠ Notice:

Do not dent the sealing surface, and assemble the driving shaft bearing with the side with oil seal facing inwards.

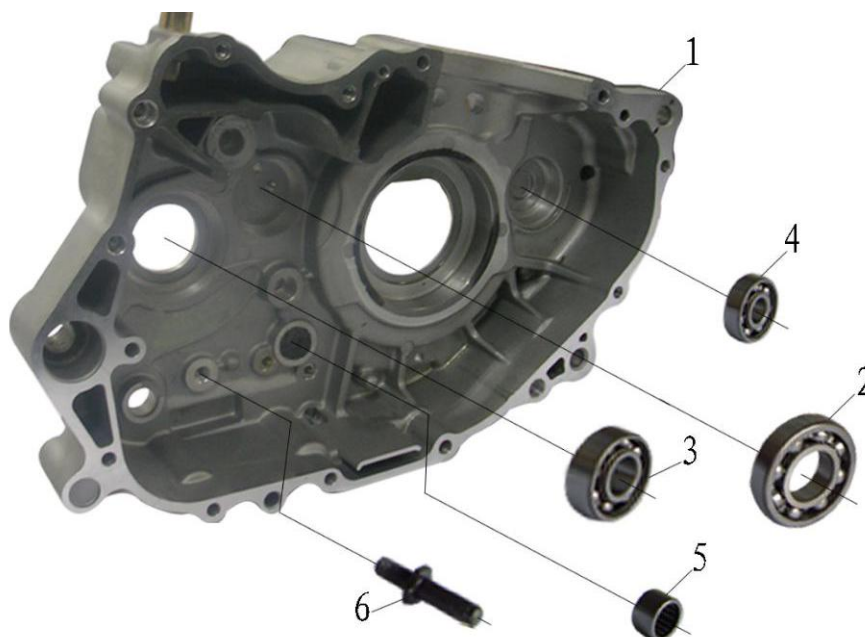

No.	Procedure	Quantity	Remarks
	Removing order		Installation is in the reverse order of removal
1	Left hand crankcase	1	Apply engine oil while assembling
2	Crankshaft bearing 6203	1	Apply engine oil while assembling
3	Driving shaft bearing 6006	1	Let the oil seal side face inward and apply engine oil while assembling
4	Balance shaft bearing 6301/13/C3	1	Apply engine oil while assembling
5	Crankshaft paper gasket -HK121610	1	Replace it with a new one while assembling
6	Arm stopper bolt M8x41	1	Do not remove it

Disassembly and assembly of right hand crankcase

Generally, do not remove the bearing; if it is removed, coat engine oil on surfaces of spare parts while pressing it in; mount it with SST and confirm the press-in depth of the bearing. Assemble the driven shaft bearing with the with oil seal facing inwards.

Disassembling the needle bearing may damage it; in case it is damaged, always change a new one.

Replace washer with new ones after being removed.

Apply the thread retaining adhesive LOCTITE 648 while assembling the stud bolt.

⚠ Notice:

Do not the sealing surface, and assemble the driven shaft bearing with the side with oil seal facing inwards.

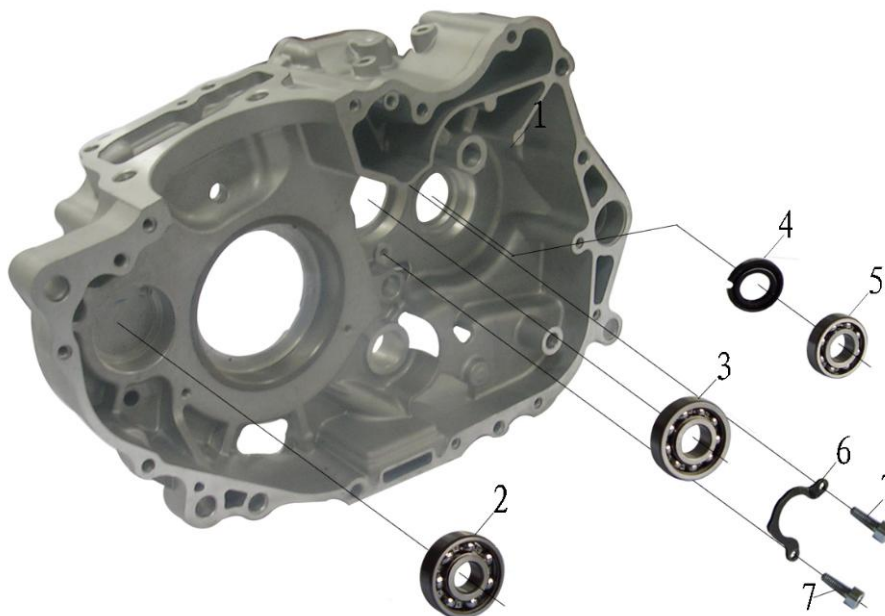

No.	Procedure	Quantity	Remarks
	Removing order		Installation is in the reverse order of removal
1	Right hand crankcase	1	
2	Balance shaft bearing 6302	1	Apply engine oil while assembling
3	Driving shaft bearing 62/22/C3	1	Let the oil seal side face inward and apply engine oil while assembling
4	Gear shift shaft oil seal 18x34x5	1	Apply engine oil while assembling
5	Driven shaft bearing 60/18RLYAB	1	Let the oil seal side face inward and apply engine oil while assembling
6	Driving shaft bearing pressure plate	1	
7	Stud bolt M6×16	2	Use thread retaining adhesive LOCTITE 648 while assembling

Crankshaft and balance shaft

To remove the crankshaft and balance shaft:

1. Remove the (left hand) crankcase (See "Removal of left hand crankcase").
2. Remove the balance shaft.
3. Remove the crankshaft.

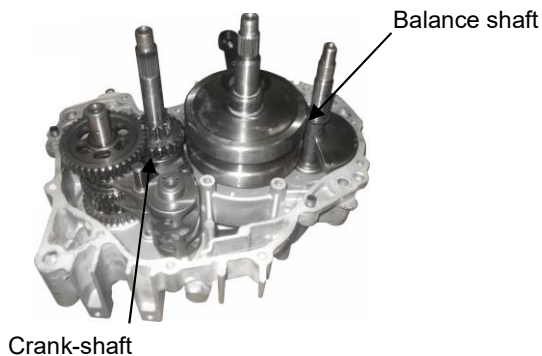

⚠ Notice:

While removing, you may strike the balance shaft and crankshaft gently; however, always avoid damaging them.

To mount the crankshaft and balance shaft:

1. Place the right hand crankcase assembled with variable transmission system (driving/driven shaft, etc.) on the assembly operating table, and use a high power electric drier to heat the right crankcase body crankshaft bearing until the temperature at the inner circle of the bearing reaches 106°C, and then assemble the crankshaft.

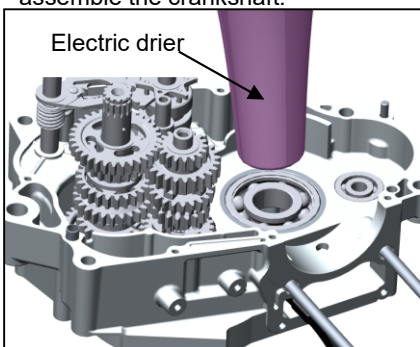

2. Use a high power electric drier to heat the right crankcase body balance shaft bearing until the temperature at the inner circle of the bearing reaches 106°C, and then assemble the balance shaft. Remember to align the markers on the driving and driven gears.
3. Mount the left hand crankcase (See "Installation of crankcase").

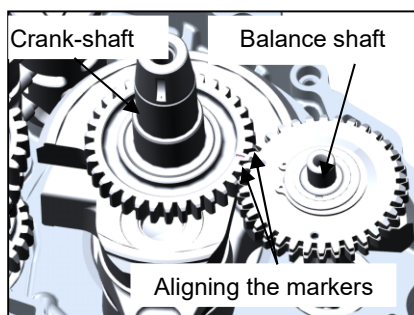

⚠ Notice:

Only assemble when the temperature reaches 106°C, otherwise it can't be assembled. Never savagely strike it!

The markers on the driving and driven gears must be aligned.

Removal and installation of crankshaft and balance shaft

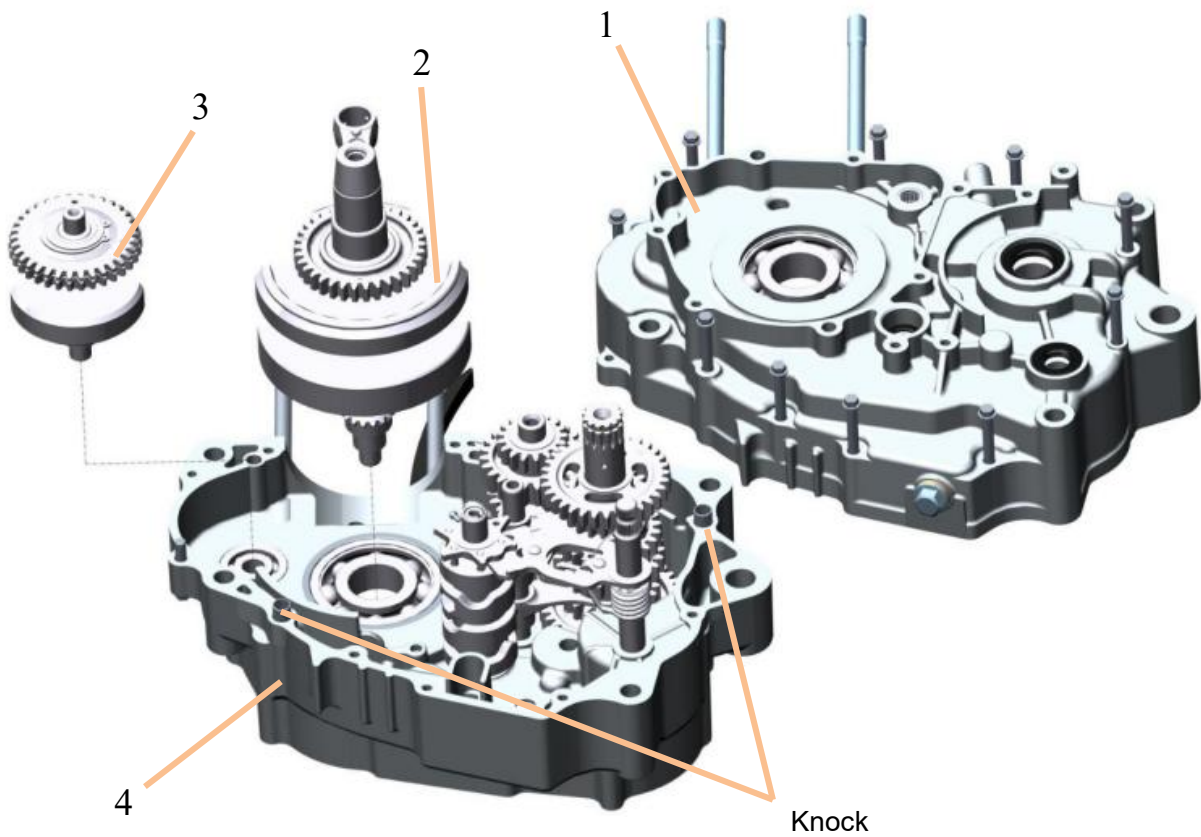

No.	Procedure	Quantity	Remarks
	Removing order		Installation is in the reverse order of removal
1	Left hand crankcase	1	
2	Crankshaft	1	
3	Balance shaft	1	
4	Right hand crankcase	1	

Disassembly and assembly of crankshaft and balance shaft

Do not further disassemble the crank shaft, otherwise the spar parts may be damaged.

Disassemble and assemble the balance shaft according to the following diagram.

⚠Notice:

Always align the markers while assembling the balance shaft.

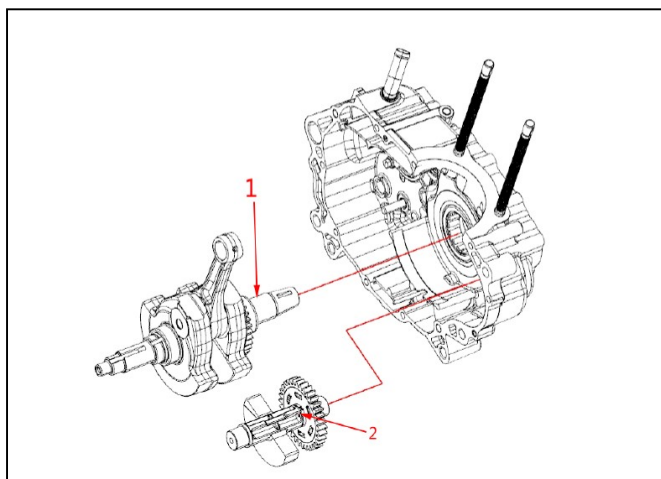

No.	Procedure	Quantity	Remarks
	Sequence of disassembling		Assembling is in the reverse order of disassembling.
1	Crankshaft connecting rod components	1	Apply engine oil while assembling
2	Balance shaft parts	1	Apply engine oil while assembling

Crankshaft and balance shaft inspection

1. Check whether the crankshaft journals are abnormally worn, whether the connecting rod can rotate flexibly and whether there is significant noise while rotating.

Measure the connecting rod small end bore diameter.

Maintenance limit: $\leq \Phi 20.063\text{mm}$.

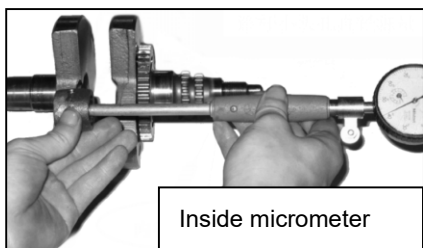

2. Measure the crankshaft radial run out.

Maintenance limit: $\leq 0.10\text{mm}$.

Radial runout

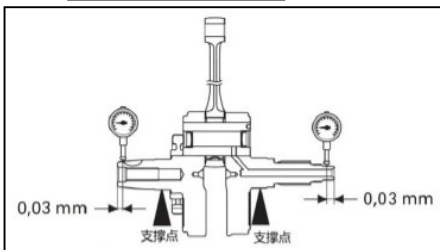

3. Measure the connecting rod big end radial clearance.

Maintenance limit: $\leq 0.06\text{mm}$.

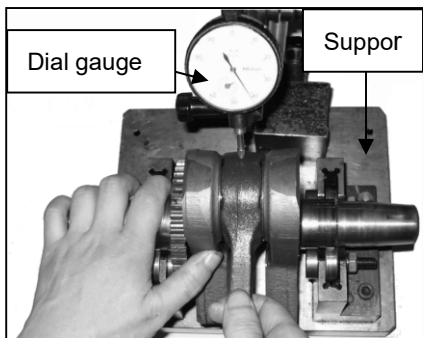

4. Measure the connecting rod large end side clearance, the maintenance limit: $\leq 0.80\text{mm}$.

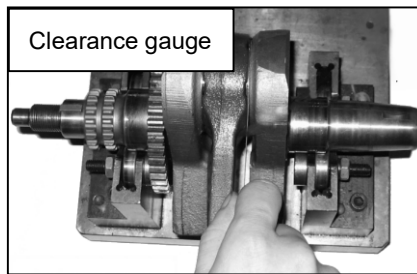

5. Measure the left hand crank journal.

Maintenance limit: $\geq \Phi 29.87\text{mm}$.

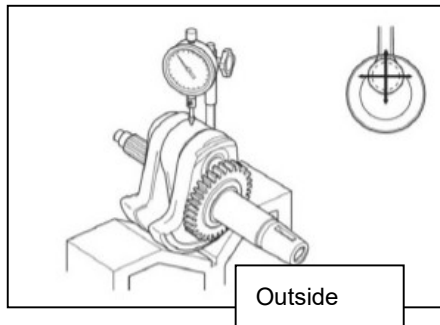

6. Check whether the balance shaft supplementary tooth spring fails and whether the balance shaft supplementary tooth can return.

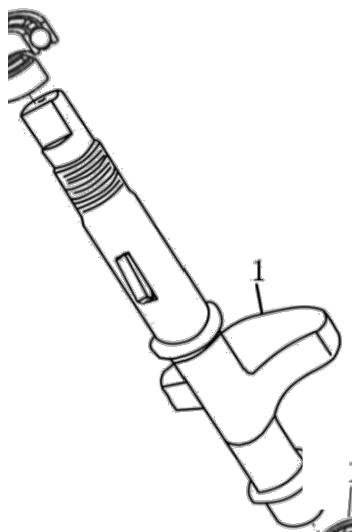

Variable transmission system

To remove the variable transmission system:

1. Remove the (left hand) crankcase (See "Removal of left hand crankcase").
2. Remove the shift fork shaft.

3. Remove the gearshift drum.
4. Remove the shift fork.
5. Remove the driving/driven shaft

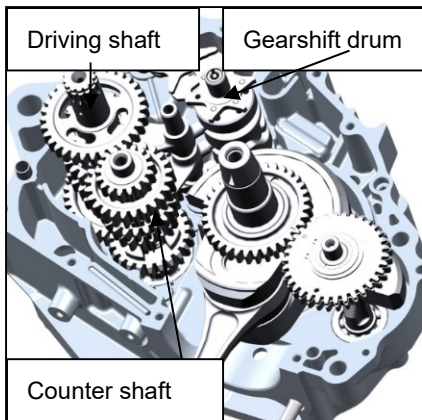

fork, and check whether the driving/driven shaft can rotate freely

5. Mount the shift arm

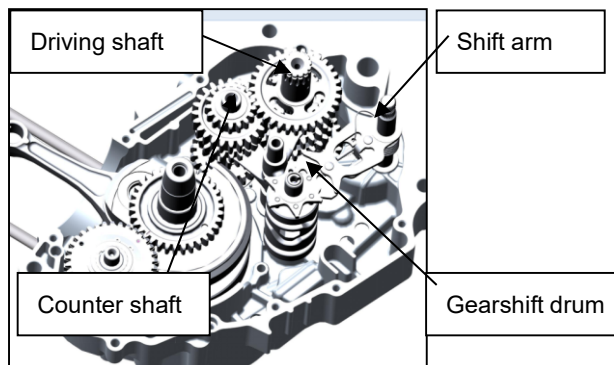

To mount the variable transmission system:

1. Place the right hand crankcase assembled with crankshaft and balance shaft on the assembly operating table, and the driving/driven shaft and assemble the them together.

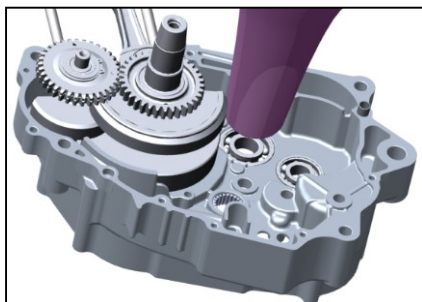

6. Replace it with a new paper pad assembly one while assembling , mount the left hand crankcase(See "Installation of crankcase")

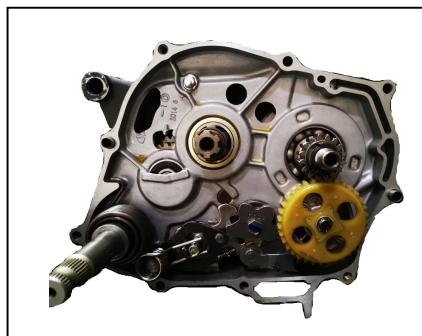

2. Assemble the shift fork with
3. Mount the gearshift drum.
4. Change the O-shaped sealing ring, mount the shift

⚠ Notice:

Only assemble when the temperature reaches 106°C, otherwise it can't be assembled. Never forcefully strike it!

Removal and installation of driving shaft and driven shaft and gearshift drum and shifting shaft

Attention: the washer, retainer, etc. must be assembled in place at the correct positions, the spare parts 8 apply lubricating oil. while assembling

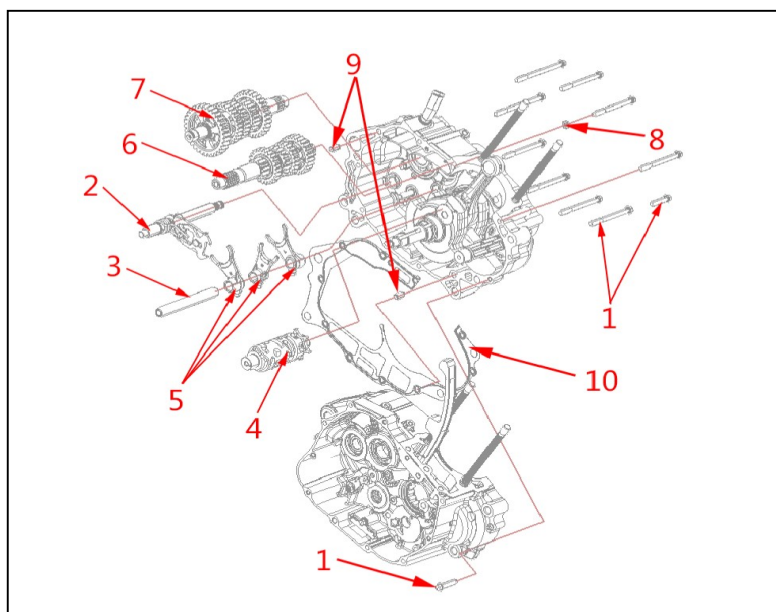

No.	Procedure	Quantity	Remarks
	Sequence of disassembling		Assembling is in the reverse order of disassembling.
1	M6×30 Hexagon flange face bolt	2	12N.m±1.5N.m
	M6×75 Hexagon flange face bolt	7	12N.m±1.5N.m
	M6×90 Hexagon flange face bolt	2	12N.m±1.5N.m
2	Shift Shaft Assembly	1	
3	Speed change fork shaft	1	
4	Shift Drum Assembly	1	Apply engine oil while assembling
5	Speed shifter	3	Apply engine oil while assembling
6	Drive spindle subassembly	1	Apply engine oil while assembling
7	Drive countershaft part	1	Apply engine oil while assembling
8	6.3×16×2 Copper gasket	1	
9	Φ8×14 Locating Hollow Pin	2	
10	CRANKCASE gasket	1	Apply engine oil while assembling

Check

Check the driving/driven shaft gears for serious abrasion and pit corrosion; check whether the shift fork is bent and whether the gearshift drum guiding slot is damaged.

Driving/driven shaft inspection

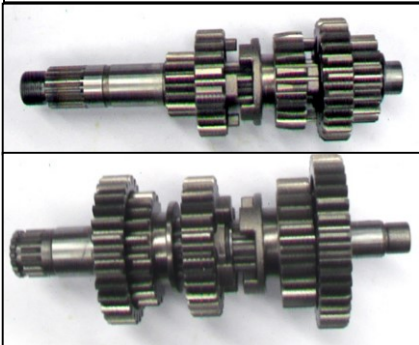

Shift fork shaft inspection

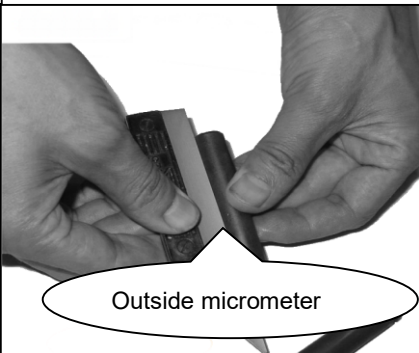

Outside micrometer

Gearshift drum inspection



Measure the shift fork claw thickness.

Maintenance limit: $\geq 5.80\text{mm}$.

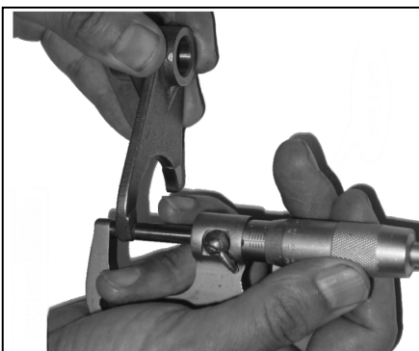

Shift mechanism

To remove the shift mechanism

1. Removal of left hand crankcase cover(See "Removal of left hand crankcase cover").
2. Remove the unloaded rotor assembly, left crankcase assembly(See "Removal of left hand crankcase cover").

Mount the left crankcase assembly

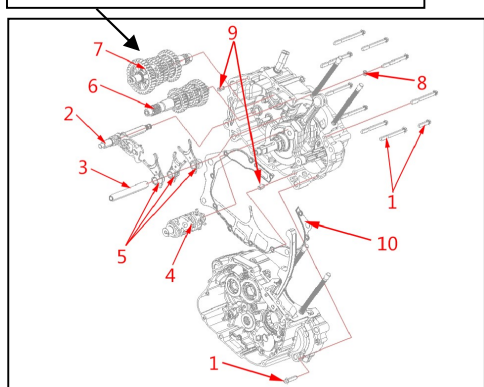

3. If only remove unloading gear arm, is not required to remove unloading gear drum assembly can be directly drawn outward shift arm combination.

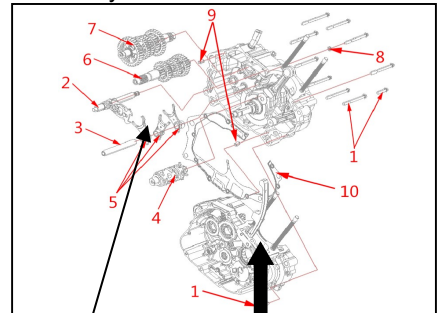

Pull out the shift arm combination

To mount the shift mechanism

1. Mount the gearshift arm combination

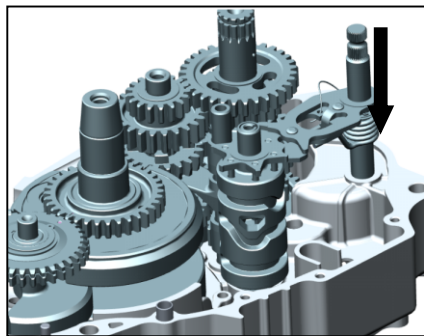

2. Mount the left crankcase body combination (Use oil seal guide to protect oil seal)
3. Mount the rotor assembly (See "Mount of left hand crankcase cover").
4. Mount the left hand crankcase cover (See "Mount of right crankcase cover").

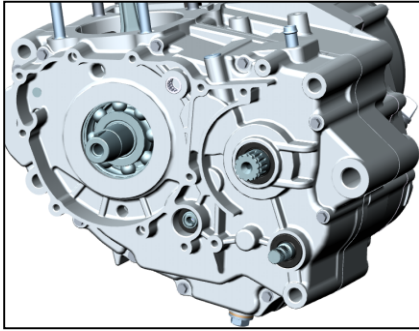

⚠ Warning

Thread retaining adhesive LOCTITE243 must be applied to the rotor retaining nut M12 while assembling, with the tightening torque being 45N.m.

10、Frame and exhaust system

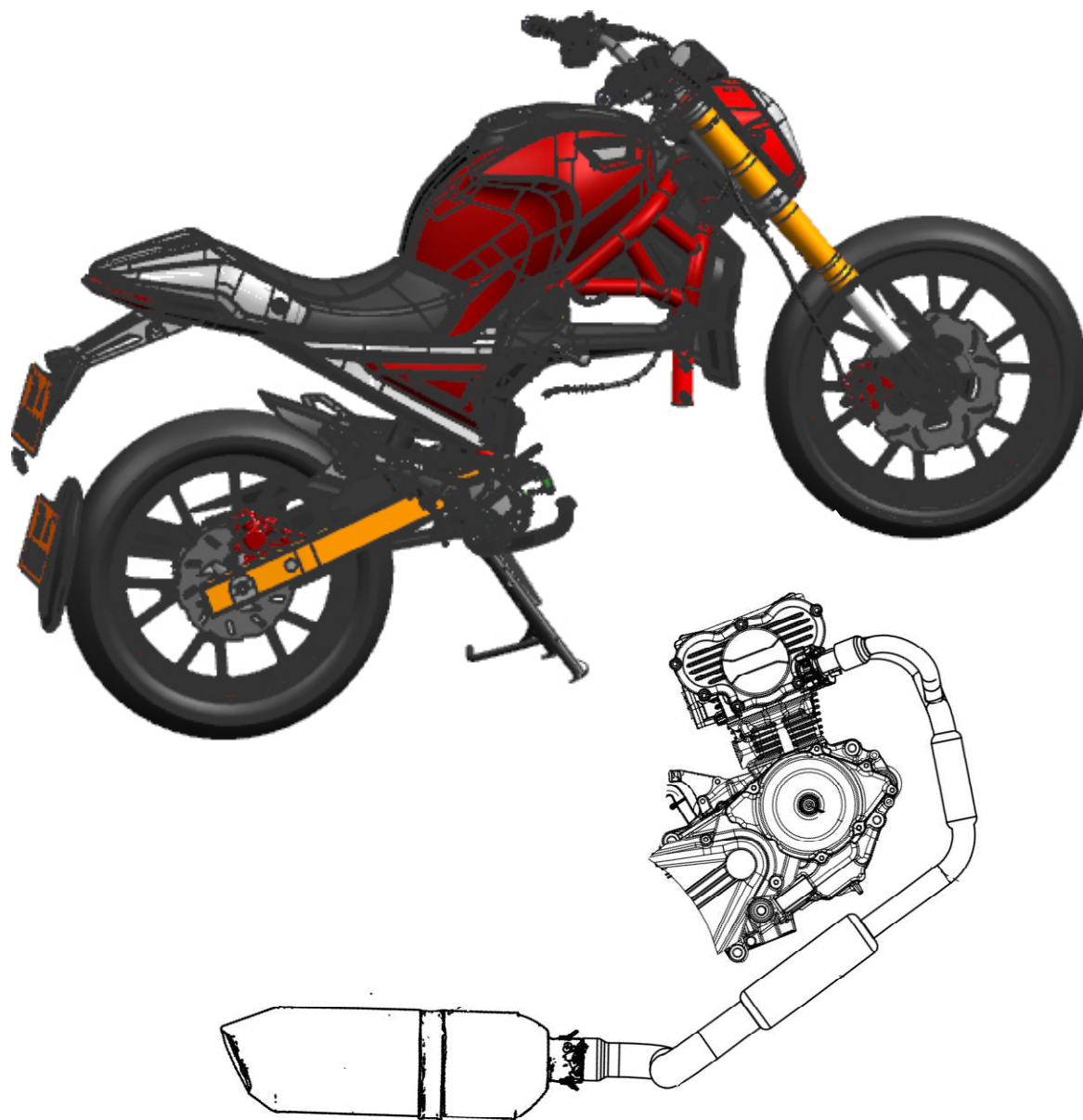

Frame and exhaust system

Maintenance notice	Removal and installation of rear mudguard
Troubleshooting	Removal / installation of exhaust muffler
Coverings, headlamp and meter	Rear position lamp assembly

Maintenance notice

To carry out the maintenance stated herein, take special care of the scratches and damages to the coverings, meter and light fittings.

Removing or repairing the parts and components before the exhaust system is cooled down may cause serious burn injury.

This section mainly includes the removal and installation of the complete vehicle's coverings, rear mudguard, exhaust muffler, radiator and lamps.

Troubleshooting

- Excessive exhaust noise

The exhaust system is damaged;

Air leakage;

- Abnormal operation

Exhaust system deformed;

Air leakage;

Muffler clogged.

Maintenance of Frame

Component description	Damage form	Trouble symptom of component	Trouble symptom of motorcycle	Repair method
Frame	The frame is deformed or broken.	The frame is deformed or broken.	Running off-tracking	Calibrate or replace frame
Main stand	Deformation or fractured	Deformation or fractured	Effect of parking	Replace the main stand
	Return spring is fractured	Main stand impossible to return	Effect of parking	Replace the return spring
Covering parts	Broken	Broken	Effect the appearance	Replace or repair Covering parts
Fender	Damaged	Broken	Effects of fender effect	Replace the fender
Seat	Broken	Broken	Decrease of the comfortable	Replace the seat
Footrest	Broken and deformation	Broken and deformation		Replace the footrest

Maintenance of Exhaust Muffler

Component description	Damage form	Trouble symptom of component	Trouble symptom of motorcycle	Repair method
Exhaust pipe gasket	The gasket is broken.	Exhaust pipe leakage.	Engine exhaust noise is too loud.	Replace the exhaust pipe gasket.
Exhaust muffler	The muffler case is broken.	The muffler case is broken.	Engine suction noise is too loud.	Replace the exhaust muffler.

Side cover and seat

- Remove the two nut, remove the seat.



- Remove the left/right side cover assembly. Handle it carefully in order to prevent scratching the exterior decorating surface.



- Remove the 2 connecting bolts in the headlamp bracket.



- Remove the 2 connecting screw in the front face of the motorcycle.



- Pull off the headlamp patch plug to remove the headlamp.

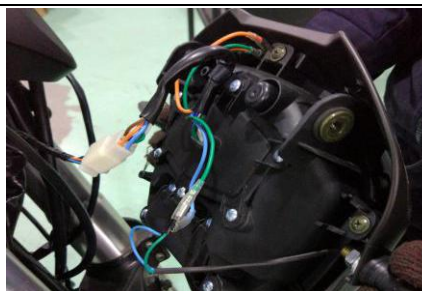

- Pull off the left/ right turn lamp connecting wire from the headlamp bracket.

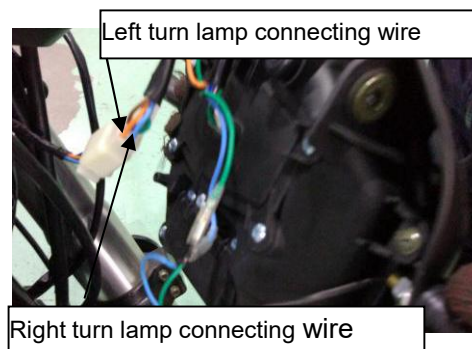

- Remove the meter assembly (total of 2 connecting bolts).



To mount the coverings, headlamp and meter:

The installation of the coverings, headlamp and meter is in the reverse order of removal. During installation, do not scratch the coverings or damage the bulb.

⚠ Notice

During removal and installation, do not scratch the outer surface of coverings or break the buckle mortise.

Headlamp dimming

Before driving, check the brightness, direction, etc. of the headlamp.

The adjustment can be made to the headlamp in the left / right and vertical directions.



Adjusting bolt

- Loosen the screw to disassemble the headlight.
- Rotating , directly unplugging
- Rotating and disassemble the bulb.
- Install the new bulb in reverse order

Headlight bulb 12V55W

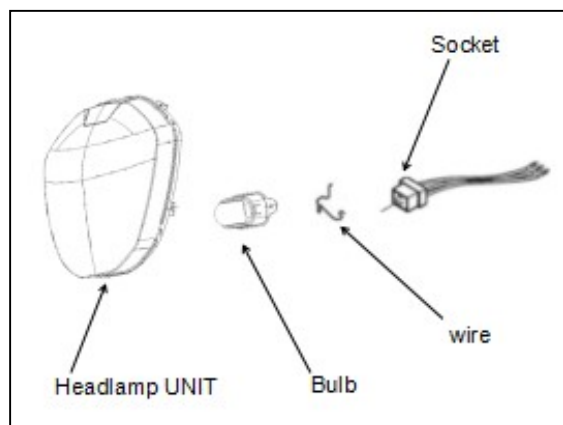

Position lamp bulb

- Unplugging the sidelight seat
- Unplugging the sidelight bulb

Replacement of turn lamp bulb

- Loosen the screws, remove the lamp lampshade
- Lightly press bulb, rotate in counter-clockwise.
- Install new bulb in opposite order as below.

Front and rear lamp bulb12V10W

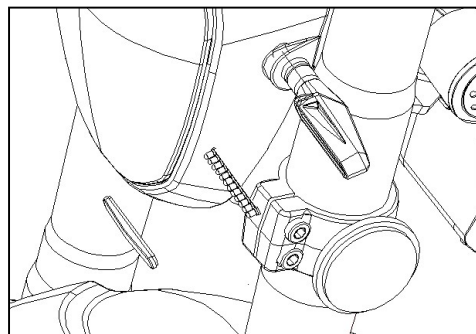

Taillight、 Taillight bulb

- Loosen the screws, remove the taillight lampshade
- Lightly rotate taillight seat, take out the seat and bulb.
- Lightly press bulb, rotate in counter-clockwise.
- Install new bulb in opposite order as below.

Taillight bulb: 12V21/5W

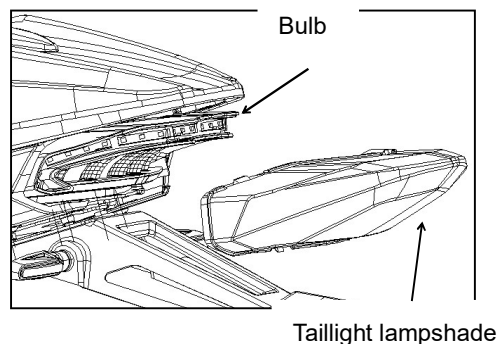

Removal / installation of exhaust muffler

To remove the exhaust muffler:

- Park the motorcycle on the plane ground with main stand; pull off the oxygen sensor patch plug.

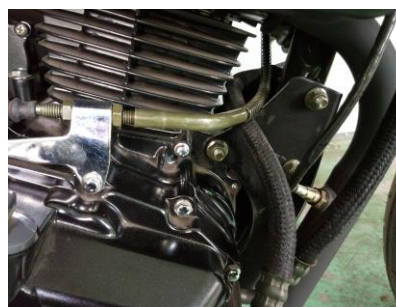

- Dismantle the suspension bolt on the muffler, check

whether it is sliding.



Connecting bolt

- Dismantle muffler connecting nut, check whether the nut and bolt is sliding.
- Dismantle the muffler, check whether the washer is damaged.

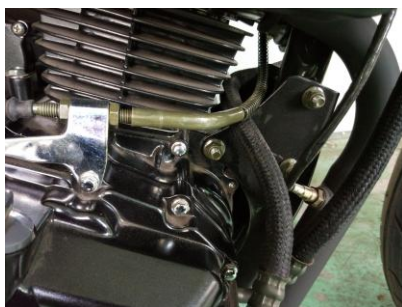

To mount the exhaust muffler:

Installation is in the reverse order of removal.

The muffler seal gasket at the engine's exhaust port shall be replaced with a new one.

While mounting, apply sealants at the joining part of the exhaust pipe and the muffler, and fasten the bolts of the exhaust port and muffler support after the joint anchor ear bolt is screwed up, otherwise air leakage may occur.

 **Notice:**

Proceed with the operation after making sure the muffler is completely cooled down, otherwise burn injury may occur.

Front wheel, front suspension device and steering stem

Maintenance notice	Front suspension device
Troubleshooting	Front brake
Control subassembly	Steering stem
Front wheel	

Maintenance notice

This section introduces the removal, installation and maintenance of the front wheel, front suspension device (front fork), front brake and steering stem. While repairing the front wheel, reliably support the motorcycle from under the engine with a jack or other supports to lift the front wheel above the ground.

Key torque values

Front wheel spindle	50N·m -60N·m
Steering handle set bolt	20~30N.m
Front fork vertical pipe cap nut	50~60N.m
Upper / lower connection plate set bolt	8~12N.m
Brake disc fastening nut	20~30N.m

Troubleshooting

- Steering unstable
 1. Vertical pipe bearing failure
 2. Tire pressure insufficient
 3. Tire damaged
 4. Wheel bush damaged
- Driving directions to the side or not to walk in a straight line
 1. Left / Right damper adjustment uneven
 2. Front fork bent
 3. Front wheel spindle bent or wheel mounted improperly
 4. Wheel bearing damaged
 5. Wheel bush damaged
- Front wheel run out
 1. Rim bent or deformed
 2. Wheel bearing worn
 3. Wheel spoke deformed or slacked
 4. Front wheel spindle slacked
 5. Tire damaged
- Wheel hard to rotate
 1. Wheel bearing or bush damaged
 2. Adjusting nut over-fastened

3. Tire pressure insufficient
 4. Shift fork bent or damaged.
- Insufficient suspension device rigidity
 1. Insufficient front fork spring
 2. Insufficient hydraulic oil refilled in the front fork
 - Poor brake performance
 1. The brake is not adjusted as per regulations
 2. Brake shoe worn
 3. Brake shoe has water or oil stain

Maintenance of Control system

Component description	Damage form	Trouble symptom of component	Trouble symptom of motorcycle	Repair method
Steering handle	The steering handle is deformed	The steering handle is bent and deformed.	Off-tracking in running.	Correct or replace steering post
Clutch handle	Over small of the free stroke		Clutch is slipping	Readjust the free stoke
	Over big of the free stroke		The clutch is not fully disconnected	Readjust the free stoke
Clutch control steel cable	The steel cable is ineffective in cable casing.	The clutch handle is impossible to control or return to the position with difficulties	Clutch slipping or is not fully disconnected	Clean、lubricate or replace control steel cable
	The steel cable		The clutch is slipping or not fully disconnected	Replace control steel cable
Rear brake pedal	The free stroke is over small.		The clutch is not fully disconnected.	Readjust the free stoke
	The free stoke is over big.		Disoperation of rear brake	Readjust the free stoke

For the damage form, fault symptom and repair method of front wheel

Component description	Damage form	Trouble symptom of component	Trouble symptom of motorcycle	Repair method
Front wheel	Front wheel rim is deformed	Front wheel rim is deformed.	Off racking in running. steering handle vibrates of shakes in running	Replace front hub
	The hub bearing hole is over worn	The bearing block hole has a loose match with the bearing.	Off racking in running. steering handle vibrates of shakes in running	Replace front rim
	Bearing is over worn or damaged.	The axial and radial gaps of bearing inner and outer rings are too big or is insufficient rotation.	Off racking in running. steering handle vibrates of shakes in running	Replace front bearing
Front tire	The tire is pricked or broken	Front tire has very low pressure	Inflexible of direction handle, insufficient engine output	Repair or replace tire
	The tire is over worn(the tire vein depth is less than		It is possible to slip and has a poor slip proof function	Replace outer tire

	2mm)			
Speedometer gear box	Gear is damaged.		The indicator of the speedometer fails to move	Replace speedometer gear box
	The gear drive ring is damaged.			

Maintenance of Front Shock Absorber

Component description	Damage form	Trouble symptom of component	Trouble symptom of motorcycle	Repair method
Front shock absorber spring	The elastic force is insufficient or broken	The elastic force of shock absorber is insufficient or broken	Front shock absorber is over Soft, abnormal sound comes out in case of front absorber working	Replace front shock absorber spring
Front shock strut	Bending and deformation	Front shock strut is bent and deformed	Off-track in running	Correct or replace front shock strut
	Working stroke surface is damaged or scratched	Leakage from oil seal	Leakage at front shock cylinder	Replace front shock strut
	Working stroke surface Cr coating partial is worn out to expose the substrate	Leakage from oil seal	Leakage at front shock cylinder	Replace front shock strut
Front shock cylinder	Broken deformed and damaged	Leakage at front shock cylinder	Leakage at front shock cylinder	Replace front shock cylinder
Piston rod	Over worn or damaged		Over soft at front shock cylinder	Replace piston rod
	Piston ring is over worn or damaged		Over soft at front shock cylinder	Replace piston ring
Oil sealing	Cut edge is over Worn or damaged or aged	Leakage from oil seal	Leakage at front shock absorber	Replace oil seal
Shock oil	Insufficient oil amount or too little	Insufficient shock oil or too little	Over soft of front shock absorber	Fill shock oil as per the specified stipulate

Maintenance of Steering Post

Component description	Damage form	Trouble symptom of component	Trouble symptom of motorcycle	Repair method
Steel ball socket	Over tight of steering stem screw	Too small gap between steel ball and steel ball steering ring	Steering handle is ineffective.	Adjust the steering post screw by tighten wrench till the steering post moves left and right flexibly and no axial shifting between steering post and frame stand pipe
	Over worn, pockmark, indentation, crack and damage of steel ball steering ring ball track		Ineffective steering handle or handle shakes or vibrates during running	Replace complete steel ball steering ring
Steel ball	The steel ball is worn, deformed and damaged.		Ineffective handle steering or handle shakes or vibrates during running	Replace all steel balls
Steering stem	The steering stem is deformed	The steering stem is deformed.	The steering stem is deformed.	Replace steering stem

For the damage form, fault symptom and repair method of front brake

Item	Damage form	Trouble symptom of component	Trouble symptom of motorcycle	Repair method
Front brake main pump assembly	brake liquid is insufficient	brake liquid is insufficient	brake lose effect	fill DOT4 to upper limit mark
	dirty brake liquid		brake lose effect	Replace the brake fluid
	surface of wall is damaged		brake lose effect	
	wall is over worn		brake lose effect	replace main pump
	oil case is cracked	oil leakage	brake lose effect	replace main pump
	piston surface is cracked		brake lose effect	replace main pump piston
	piston is damaged		brake lose effect	replace main pump piston
Front brake caliper	air entry into oil pipe		brake lose effect	exhaust front brake oil way
	oil pipe is broken	oil leakage from oil pipe	brake lose effect	replace oil pipe
	front brake oil pipe is clogged	oil pipe is clogged	brake lose effect	clean or replace oil pipe
	wall is broken or cocked		brake lose effect	replace front brake caliper
	wall is over worn		brake lose effect	replace front brake caliper
	front brake caliper is broken	oil leakage from front brake caliper	lose effect	replace front brake caliper
	seal ring is broken or worn	oil leakage	lose effect	replace front brake caliper
	friction plate is over worn		lose effect	replace friction plate completely
	surface of piston is damaged or worn		abnormal sound or lose effect	replace brake caliper piston
	guide pin is clipped		front brake lose effect or spring cannot be returned	clean or lubricate guide pin
Front brake disc	over worn(less than limit value3mm)		front brake lose effect	replace front brake disc
	distorted		abnormal sound or lose effect	replace front brake disc

Control subassembly

1. Remove the left/right balance weight.



2. Remove the right handle and right combination switch

- Pull off the brake switch leads

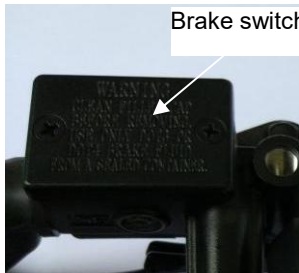

- Remove the upper/lower body of the right combination switch



- Remove the throttle control line

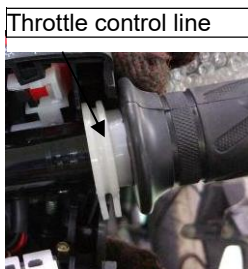

- Remove the right combination switch

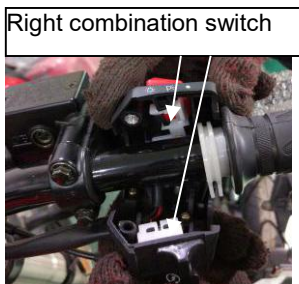

- Remove the right brake cylinder body.

Remove the right brake cylinder body

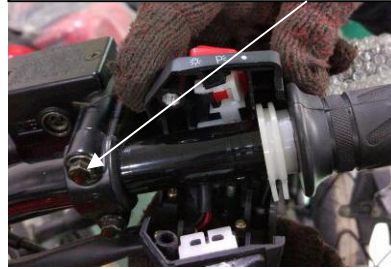

- Remove the clutch control line and disassemble the connection of the clutch switch leads and the main cable.

Remove the left combination



Clutch control line



- Remove the left combination switch.

Remove the left combination



- Loosen the retaining bolt and remove the clutch handle holder.

Retaining bolt



- Remove the clip and take out the grip tube

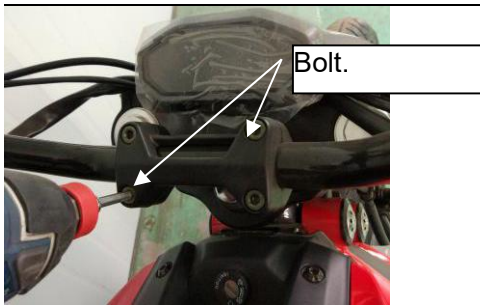

To install the control subassembly

- 1) Installation is in the reverse order of removal. While installing the brake cylinder body, make sure the cylinder is in the same height as the original mounting position to prevent air from entering the main fuel cylinder, thus influencing the braking performance. Do not twist the braking hose.
- 2) While installing, the clutch handle holder and the front brake cylinder body notch shall be aligned with the mark point of the grip tube, and the pins of left/right combination switch shall be blocked into the pin holes of the grip tube.
- 3) Steering column opening and a handlebar tube positioning point alignment, and fasten the bolt at the connection board, and then the bolt at direction of the tube, up to the torque of 20-30N.m.
- 4) Do not mount the throttle cable in the opposite direction of the feeder on the right handle, otherwise the handle may rotate incorrectly while refueling.
- 5) Upon installation, adjust the throttle control line. Upon installation, check whether the cable and wiring is in accordance with the wiring diagram.

Maintenance of wheel

To remove the front wheel

Support the motorcycle with a jack to lift the front wheel above the ground.

Dismantle nut of front wheel axle and check it whether is distorted.

Unscrew the front wheel spindle and take it out.



Take out the front wheel. Lift the front fork as high as possible while taking out the front wheel, to avoid damaging the front mudguard.

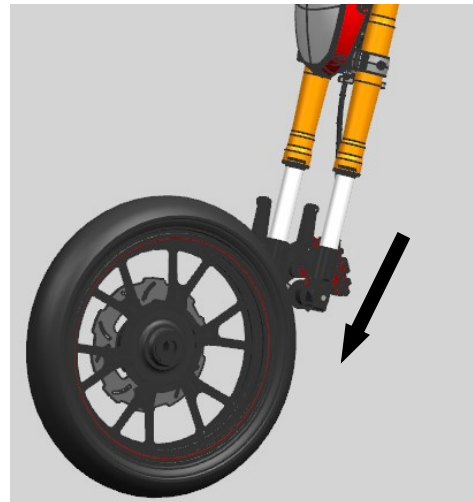

To mount of the front wheel

While installing, fasten the front wheel spindle nut to the required torque of 50-60N.m

Warning

The front wheel spindle must be firmly screwed up to the required torque of 50-60N.m.

Disassembly and assembly of front wheel

Disassemble and assemble the front wheel according to the following diagram.

After the bearing is removed, replace with a new bearing along with dust seal.

While assembling the brake disc, apply small amount of thread retaining adhesive LOCTITE243 on the threads of the screw, with tightening torque being 20-30N.m.

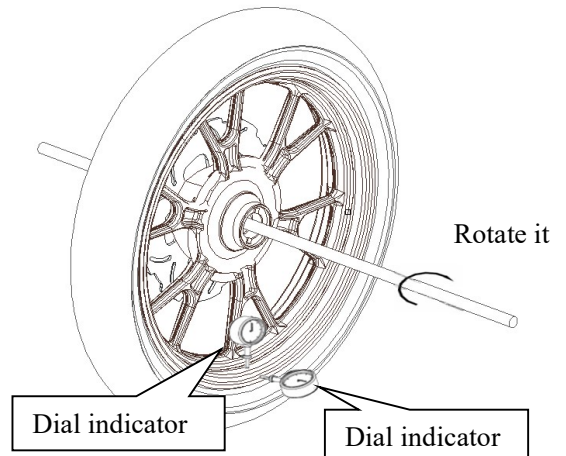
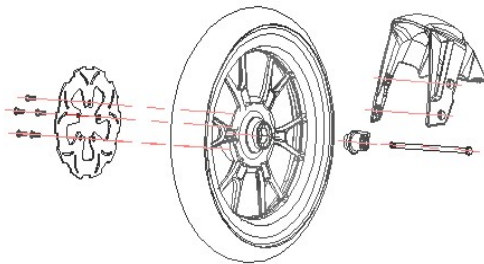

Front suspension device

Front suspension device

Removal of coverings) and front wheels (See Removal of front wheel).

Remove the front mudguard and front license plate. Do not scratch the outer decorating surface

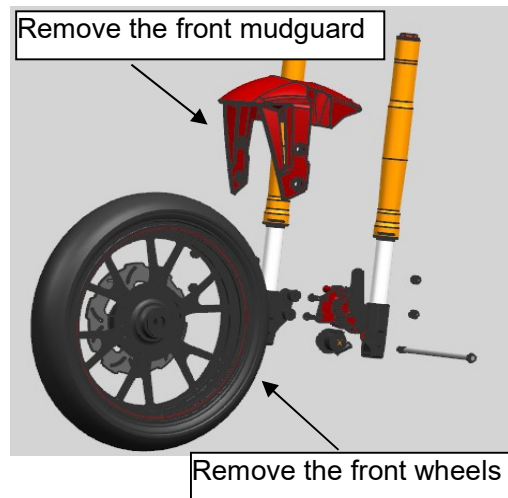

Warning

The brake disc retaining screw must be coated with thread retaining adhesive, with the tightening torque being 20-30N.m. Otherwise, it may cause a personal safety accident.

Front wheel spindle inspection

Place the front wheel spindle on the V-holder, and measure the deflection of the wheel spindle with a dial gauge; if the reading is no less than 0.2mm, replace the front wheel spindle.

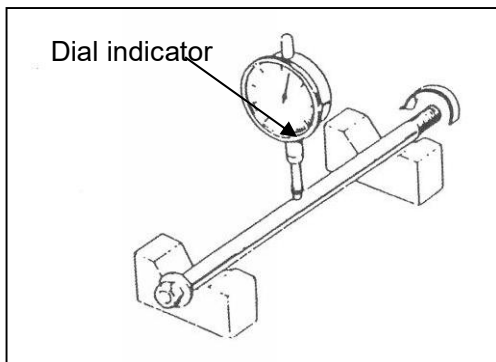

Remove the front brake caliper and wire clip

Remove the wire clip and speed sensor

Front brake caliper



Front wheel bearing inspection

Place the front wheel on the calibration table, inspect the rim's deflection, and then manually rotate the wheel and measure its deflection value with a dial gauge; if the reading is no less than 2mm, replace the wheel bearing

Unscrew the upper / lower connection plate bolt and. the direction of the tube bolt

Pull off the front damper

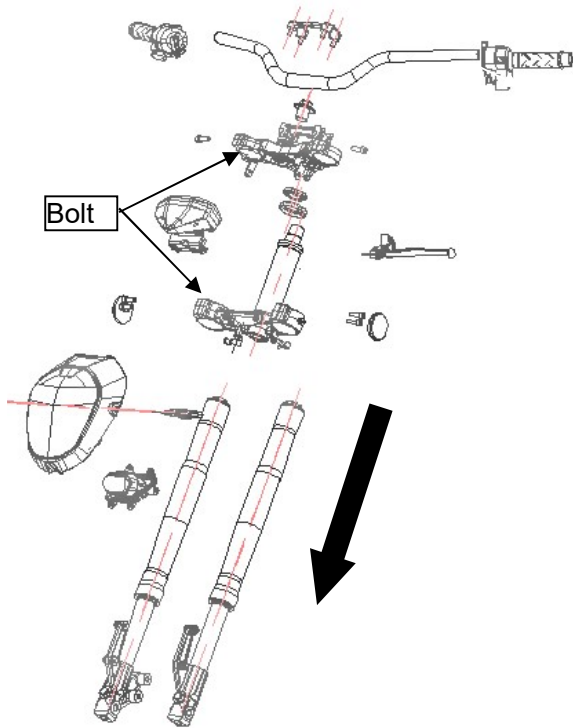

To install the front fork:

Installation is in the reverse order of removal.

⚠ Notice

While removing the front brake caliper, if it is unnecessary to replace, never nip the front brake handle. While installing the front brake caliper, apply the thread retaining adhesive LOCTITE 243, with the tightening torque being 20-30N.m

Check

- 1) Dismantle oil drain bolt and check bolt whether or not is loose.
- 2) Drain off absorber oil and check quality whether or not is turned.

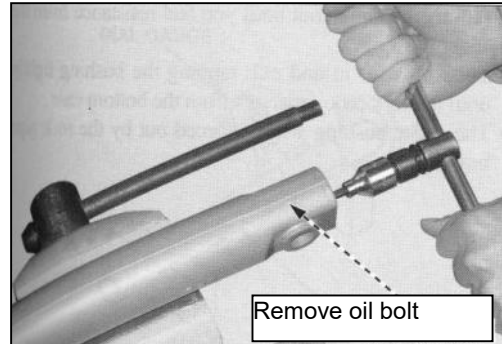

- 3) Take off dust sleeve, circlip and oil seal to check edge whether or not is worn and circlip is distorted.

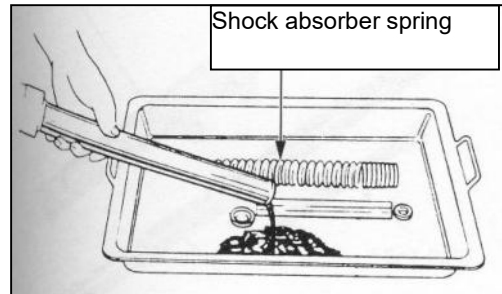

- 4) Oil seal assembly: in primary lip and the dust lip between coated with lubricating grease, oil seal mark up

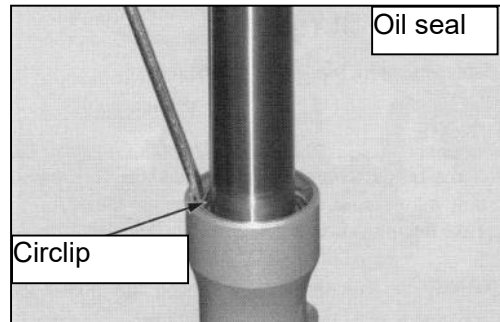

- 5) Check inner pipe whether or not is worn.

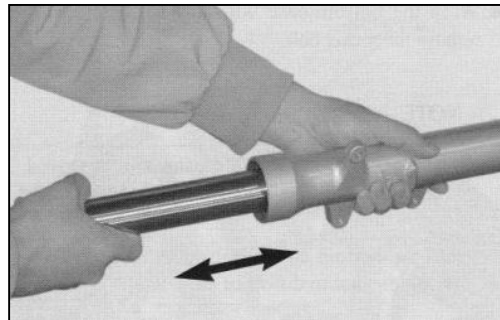

- 6) Dismantle circlip and return spring to check whether or not there are elasticity

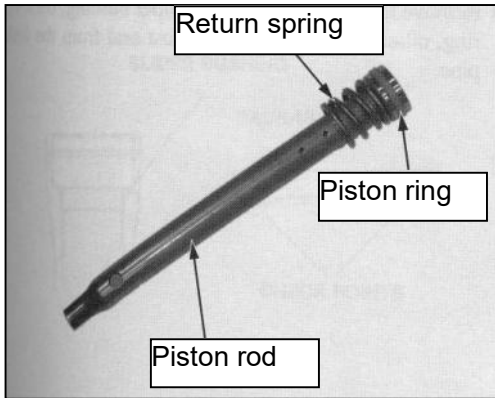

- 10) Fill absorber oil per standard.

Oiling quantity: $250 \pm 2\text{ml}$, the brand is CN1# shock absorber oil, injected before the strict filtering, does not allow water, sand and other foreign bodies into the

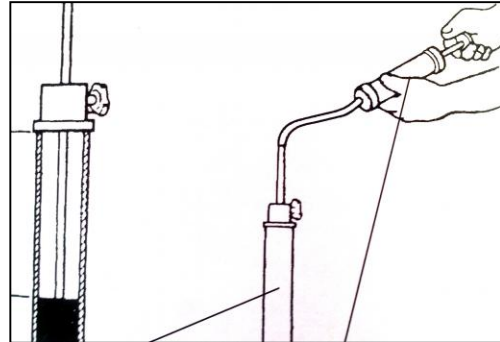

- 7) Measure internal diameter to check whether or not is it worn.

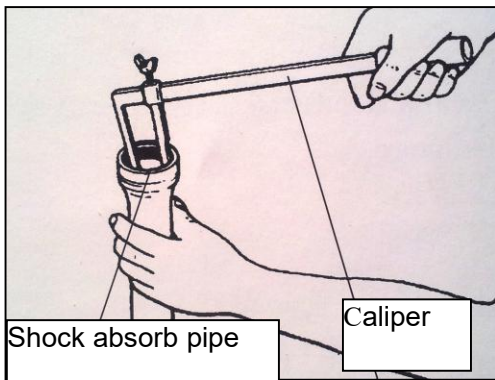

- 8) Measure free length of absorber spring and check it whether or not is distorted.490mm

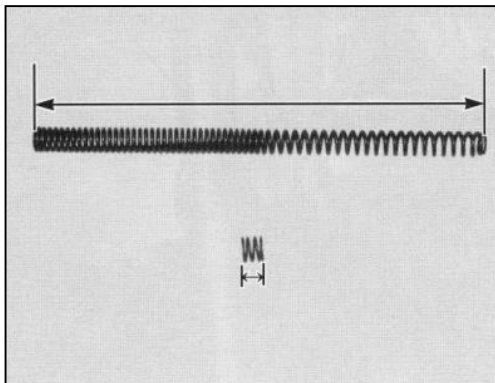

- 9) Check length of return spring to check it whether or not is distorted.29mm

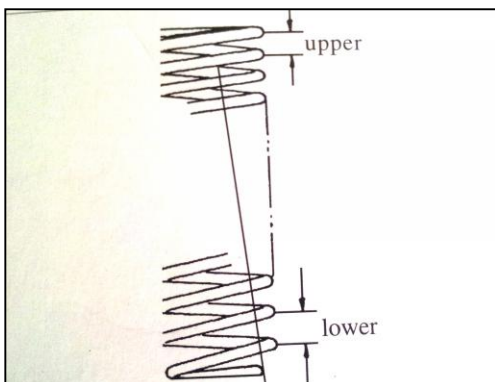

Removal of steering stem

Steering stem

- 1) Park the motorcycle on the plane ground, and remove front wheel, front fork and grip tube (control subassembly) of the whole vehicle. Refer to the related sections

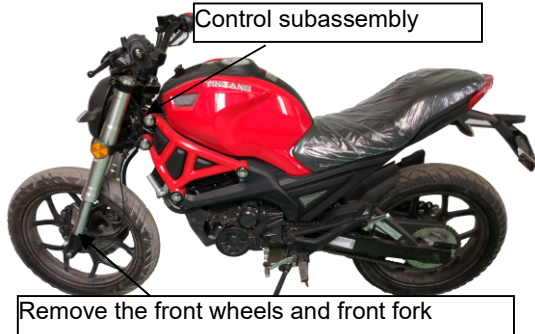

- 2) Remove the upper connect plate

Upper connect plate

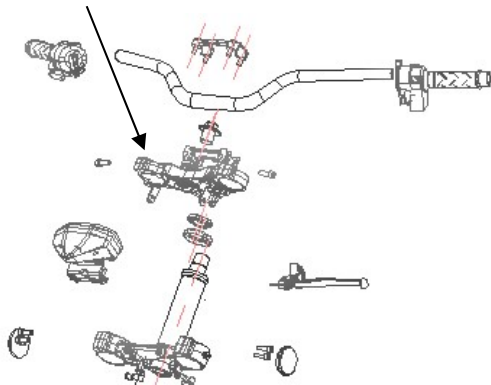

- 3) Use special socket for adjusting nut  Unscrew the adjusting nut.



- 4) Lower steering stem

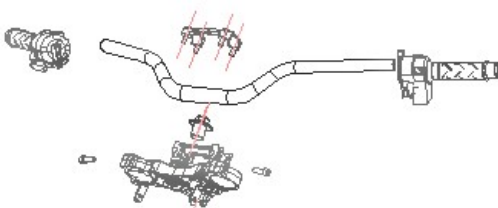

To mount of steering stem

Installation is in the reverse order of removal

While installing the steering stem, adjust the adjusting nut and inspect it by turning it left and right and moving it up and down to ensure no vertical play and flexible rotating laterally.

Tighten the cap nut to the required torque of 60-70N.m.

Front brake

Front brake caliper inspection

- 1) Dismantle front brake caliper bolt

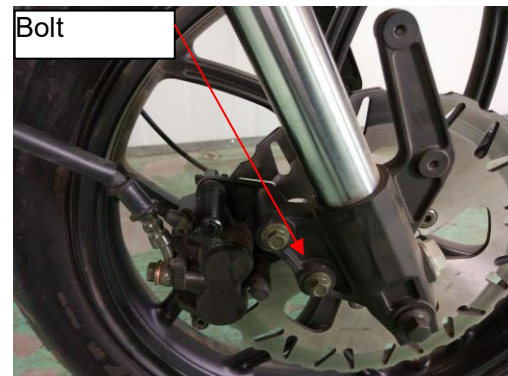

- 2) Operating brake, if the wears limit line of the brake shoe touch to the side of the brake disc. It shows that the brake shoe has touched the wear limit.

Replace the brake shores.

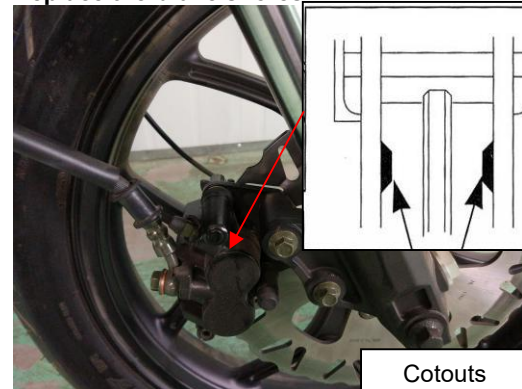

- 3) Take off front brake caliper and check brake shoe whether exceed limit value



 **Warning:**

When it is replaced with a new brake strip or brake disc, do not drive it immediately; instead, drive it after holding and releasing the front brake handle until the brake strip and the brake disc are well engaged.

Front brake disc inspection

Measure the thickness of the brake disc with an outside micrometer; if the thickness is no more than 3mm, replace the front brake disc. Measure the runout of the brake disc with a dial gauge;

maintenance limit:0.2mm



12. Rear wheel and rear suspension device

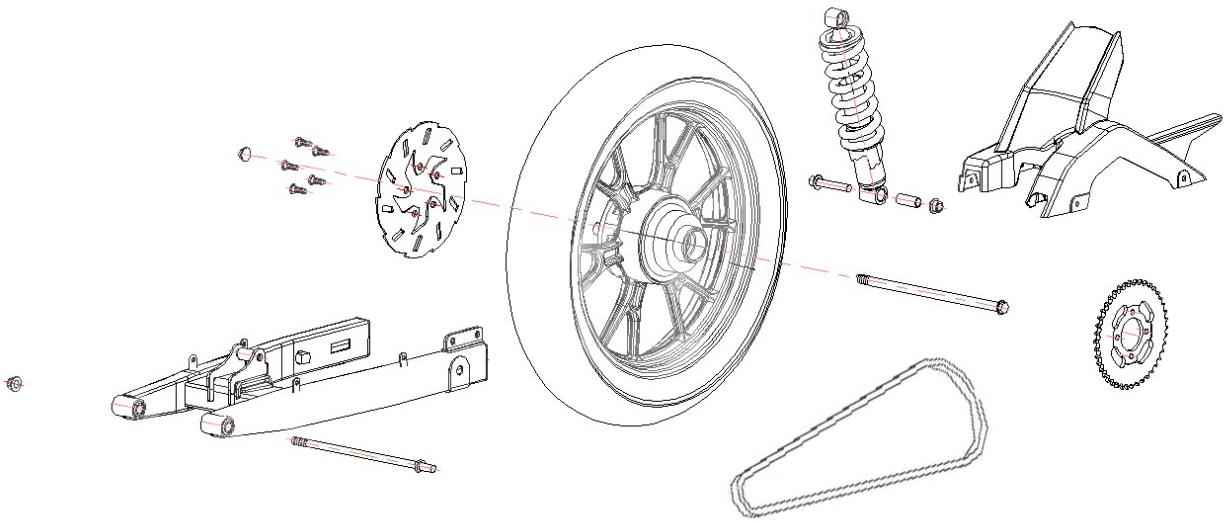

12、Rear wheel and rear suspension device

Maintenance notice	Rear fork
Troubleshooting	Rear shock absorber
Rear wheel	

Maintenance notice

This section introduces the removal, installation and maintenance of the rear wheel, rear brake, rear fork and rear damper .While repairing the rear wheel and rear damper, reliably stand the motorcycle from under the engine a jack or other supports.

Key torque values

Rear wheel spindle nut	60-90 N.m
Rear fork shaft nut	50-60N.m

Troubleshooting

• Rear wheel shimmy

- 1 Rim bent;
- 2 Rear wheel bearing worn;
- 3 Low tire pressure;
- 4 Regulator differs between left and right;
- 5 Wheel bush damaged.

• Wheel hard to rotate

- 1 Wheel bearing or bush damaged
- 2 Wheel incorrectly mounted;
- 3 Rear wheel spindle bent

• Suspension device abnormal

- 1 Damper spring too stiff or too weak;
- 2 Rear fork bearing worn;
- 3 Damper bent.

• Foreign noise

- Fasteners loosened

For the damage form, fault symptom and repair method of rear wheels

Component description	Damage form	Trouble symptom of component	Trouble symptom of motorcycle	Repair method
Rear wheel	Rear rim is twisted and deformed.	Rear rim is twisted and deformed.	Off racking in running. rear wheel wobbles in running	Replace rear rim
	The hub bearing hole is over worn	The bearing block hole has a loose match with the bearing.	Off racking in running. rear wheel wobbles in running	Replace rear rim
	The bearing is over worn and damaged	The axial and radial gaps of bearing inner and outer rings are too big or is insufficient rotation.	Off racking in running. rear wheel wobbles in running	Replace bearing
Rear tire	The inner tire is pricked or broken	Rear tire has very low pressure	Inflexible of direction handle, insufficient engine output	Repair or replace inner tire
	The tire is over worn (the tire vein depth is less than 2mm)		It is possible to slip and has a poor slip proof function	Replace outer tire

Maintenance of Rear Transmission

Component description	Damage form	Trouble symptom of component	Trouble symptom of motorcycle	Repair method
Sprocket and cam sprocket	Gear is over wor		Drive chain has abnormal sound, drive chain is easy to fall out.	Replace sprocket and cam sprocket
Drive chain	Too dirty or poor lubrication		Drive chain has abnormal sound	Clean and lubricate the chain.
	Improper chain tightness.	Chain is over tight	Drive chain has abnormal sound	Adjust the chain tightness to 15~25mm
		Chain is over loose	Drive chain is easy to fall out.	Adjust the chain tightness to 15~25mm
	Over worn		Drive chain has abnormal sound, and is easy to fall.	Replace drive chain

Maintenance of Rear Suspension

Component description	Damage form	Trouble symptom of component	Trouble symptom of motorcycle	Repair method
Rear shock absorber assembly	Rear shock absorber spring is broken or with insufficient elastic force	Rear shock absorber spring is broken or with insufficient elastic force	Rear shock absorber is over soft or over hard	Replace rear shock absorber spring
	Leakage at rear damper	Leakage at rear damper	Leakage at rear shock absorber, rear shock absorber is over soft	Replace rear damper
	Piston rod on rear damper is bent, deformed or broken	Piston rod on rear damper is bent, deformed or broken	Rear shock absorber is over hard	Replace rear damper

Rear wheel

To remove the rear wheel

- 1) Stand the motorcycle with a jack to lift the rear wheel above the ground.
- 2) Remove the chain set.



Remove the chain set

- 3) Unscrew the rear wheel nuts, the brake pull rod, Brake limit lever and remove the rear wheel spindle.
- 4) Dismantle rear wheel axle nut to check it whether is loose and damaged



- 5) Remove the chain link and remove the drive chain.
- 6) Dismantle clip of chain and take off chain

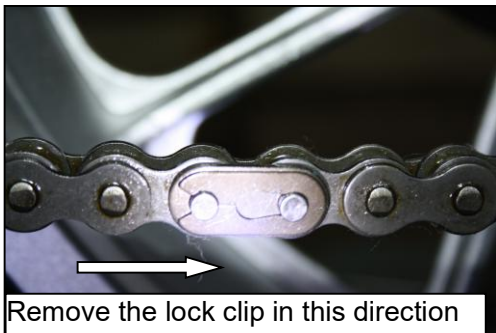

Remove the lock clip in this direction

- 7) Take out the rear wheel assembly and the spindle bush.

Installation of rear wheel

Installation is in the reverse order of removal. While mounting the rear wheel, make sure the spindle bushes on both sides are aligned and the brake caliper clamps the rear wheel brake disc. While installing, properly adjust the chain adjuster to ensure that the chain

slack is between 20mm and 30mm and that the left and right scale lines of the chain adjuster are consistent, and then fasten the rear wheel spindle nut to the required tightening torque of 60-90N.m

Warning

The rear wheel spindle must be firmly screwed up to the required torque of 60-70N.m

Rear wheel spindle inspection

Place the rear wheel spindle on the V-holder, and measure the deflection of the wheel spindle with a dial gauge; if the reading is no less than 0.2mm, replace the rear wheel spindle.

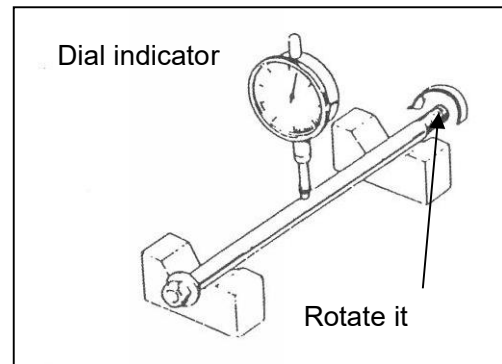

Rear wheel bearing inspection

Place the rear wheel on the calibration table, inspect the rim's deflection, and then manually rotate the wheel and measure its deflection value with a dial gauge; if the reading is no less than 2mm, replace the wheel bearing.

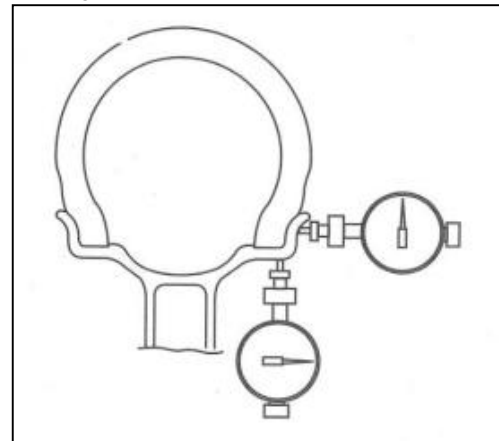

Rear sprocket inspection

Check the tooth form of the rear sprocket, and replace it in case of serious damage. While replacing, directly remove the nut; and apply the thread retaining adhesive LOCTITE243 on the rear sprocket retaining screw, with the tightening torque being 20-30N.m.

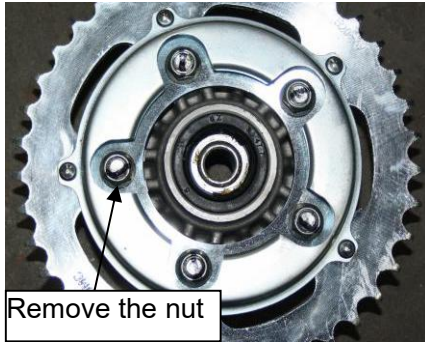

Take out bush and dismantle bolt of rear driven chain disc.

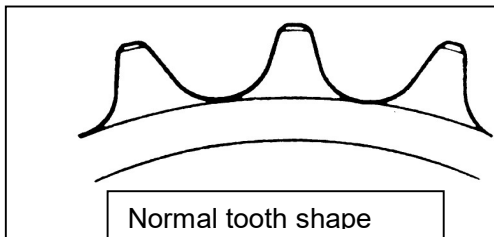

Check rear driven chain disc whether it is exceed limit value.

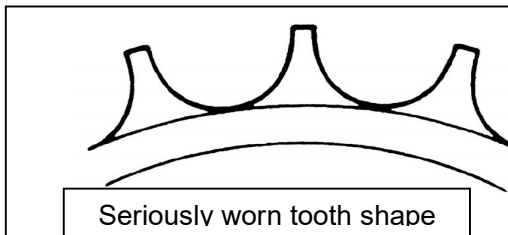

Check chain abrasion and deformation.

Check chain joint pin whether is loose or worn and clip whether is deformed

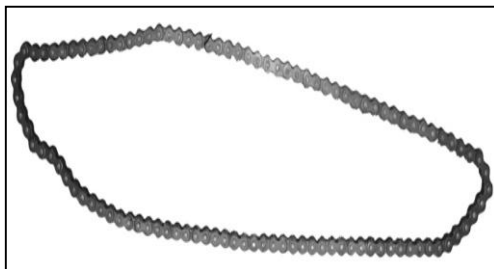

Rear fork
To remove the rear fork:

- 1、 Remove the rear wheel assembly first (See “Removal of rear wheels”).
- 2、 Unscrew the rear fork shaft nuts and pull out the rear fork shaft from the left

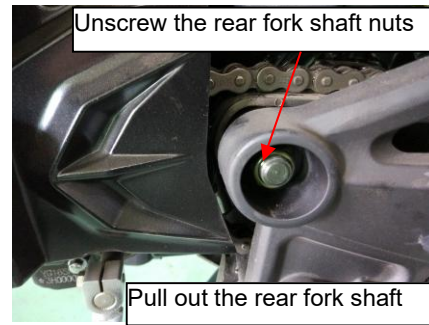

3、 Remove the rear damper and rear fork connecting bolt.

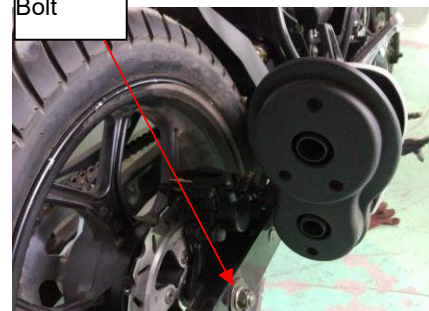

4、 Take out the rear fork backwards.



To install the rear fork:

Installation is in the reverse order of removal..

While installing the rear fork shaft, make sure that the end covers shall be aligned and that the tightening torque of the rear fork shaft retaining nut is 50-60N.m,

⚠Warning:

The rear fork retaining nut must be firmly screwed up to the required torque of 50-60N.m.

Rear fork shaft inspection

Place the rear fork shaft on the V-holder, and measure the deflection of the rear fork shaft with a dial gauge; if the reading is no less than 0.2mm, Replace the rear fork shaft.

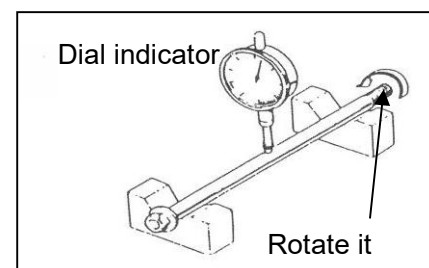

Rear fork bearing inspection

Replace the removed seal ring and needle bearing with new ones. After installation, ensure the needle bearing is 3mm away from the end face and apply lithium base grease on the needle bearing. After the installation is complete, check whether the needle bearing can rotate flexibly.



Disassemble, assemble and check rear absorber

Remove the bolt connecting the frame

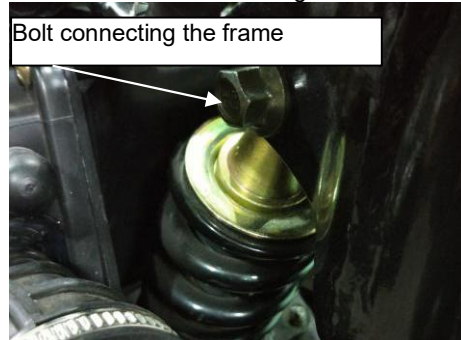

Remove the bolt connecting the rear fork.

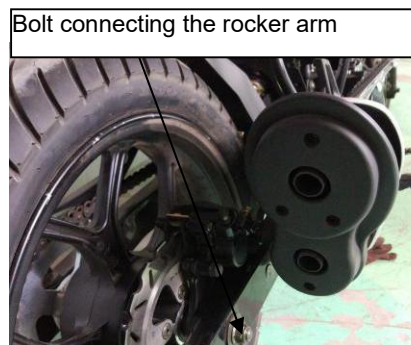

To install the rear damper:

Installation is in the reverse order of removal. While installing, use the upper hole for the lower installation of the damper.

⚠ Notice:

Before removing the damper, the tightening torque of the bolt connecting the frame is 30-40N.m, and the tightening torque of the bolt connecting the rear fork is 30-40N.m

Rear Brake

Pulling the front & rear brake, checking the wear and tear

of the brake shoe. If the mark "△" on the drum brake cover and also on the brake cam alignment, shows the brake shoe has been touched the wear limit. Please change it.



Disconnect the rear wheel

Remove the brake on the rear wheels

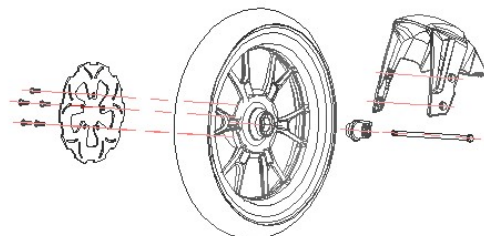

Brake shoe block in working state, the cylindrical Φ 160
Remove the fixed shoe circlip, remove the shoe

13、 General remarks of electrical system

Precautions for circuit inspection	System principle and composition
------------------------------------	----------------------------------

Precautions for circuit inspection

1. While disengaging or engaging the patch plug, turn the ignition switch to OFF position, otherwise the electrical elements may be damaged.
2. While checking the circuit, use a stylus that can be inserted from the front and rear ends of the connector and can contact the terminals reliably.
3. To carry out the line on/off inspection, turn off the power supply and the related electrical elements.
4. To carry out inspection with voltage, check the accumulator voltage first.
5. In case of electrical system failure, diagnose according to the following steps:
 - A. Observe the failed behavior to determine which sub-system fails.
 - B. According to the circuit schematic drawing, use the process of elimination (POE) to narrow down the possible failure scope.
 - C. Check the sub-system line for open circuit, short circuit or wrong connection.
 - D. Check the related components for failure or damage.
6. While looking up the line failures, check where the removal is convenient first following the principle of “searching from easy to difficulty”. Both the parameter detection method and the parts replacement method are acceptable. However, if the parts replacement method is used, you should confirm whether or not overload has occurred in the line, as this may damage the new spare parts.
7. A multimeter must be permanently available for the circuit inspection.
8. Most of the instant electrical failures are caused by cable connector or electric wire failure.

System principle and composition

The electrical system is an important guaranty for the motorcycle's running, safety running, reliable running and efficient running. It involves many aspects, including contents of several subjects, including electric machine, electrical, electronics, computer, electrochemistry, acoustics, optical material, etc. The development of electronics will especially influence the motorcycle's electrical system significantly. YG125-30A's electrical system uses a lot of advanced vehicle electronics technologies that are much more complicated than the traditional motorcycle. It comprises the following sub-systems:

- Power supply system
- Starting system
- Engine management system
- Illumination signal system
- Information display system

We shall give detailed explanations separately in the following sections

14、 Power supply system

Overview	Major parts and components
Circuit schematic drawing	Major faults diagnosis
Maintenance of Charging System	

Overview

Power supply system is the precondition for a complete vehicle to operate, capable of providing sufficient electric energy for other electrical systems. The main contents include recharging, charge storing and discharging. YG125-30A power supply features large power supply capacity as high as more than 250W. It comprises the following parts and components:

- Magneto
- Variable voltage rectifier
- Accumulator
- Combined ignition switch
- Various fuses

Circuit schematic drawing

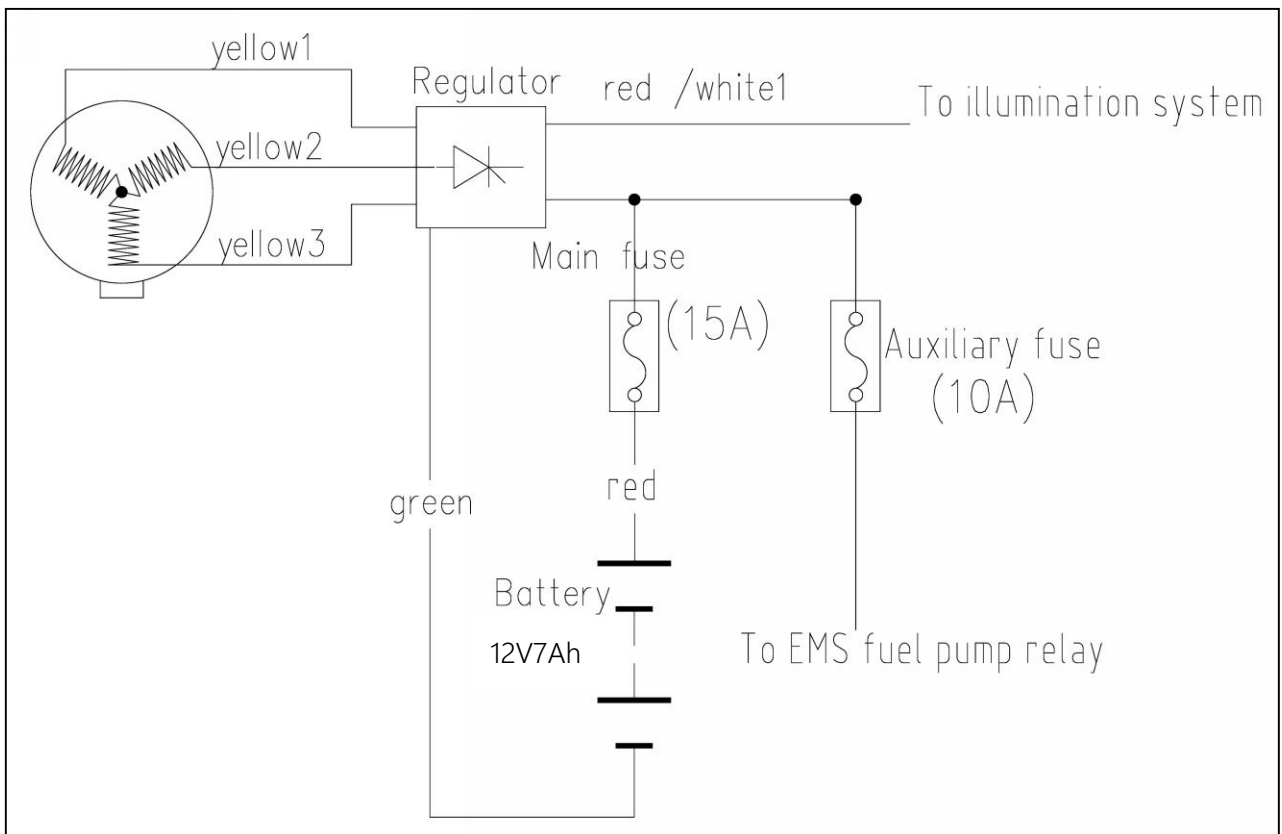

Maintenance of Charging System

Disassemble, assemble and check charging system

1. Check socket whether contact well.



2. Dismantle rectifier bolt and measure two yellow wire whether is short circuit or broken circuit by millimeter.

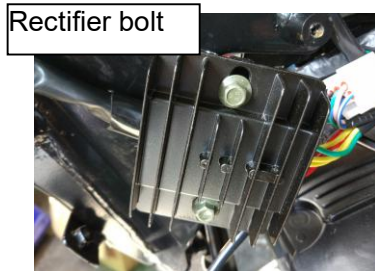

3. Open left cover to check magneto coil whether is burned or loose.
4. Dismantle magneto bolt and replace magneto coil.

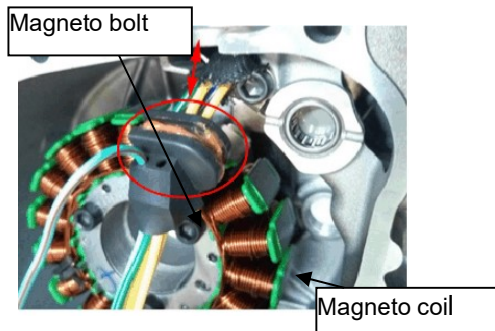

5. Dismantle starting clutch and replace magnetic

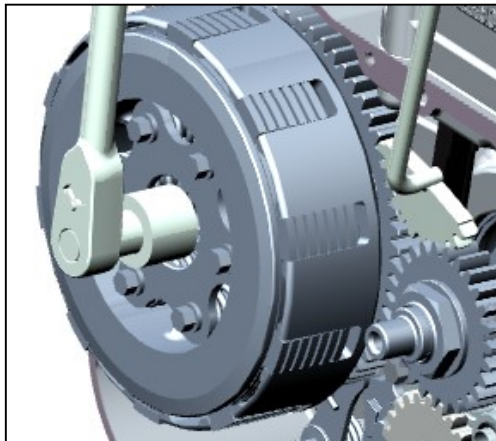

6. Check plate electrode whether is damaged



7. check connector socket of rectifier and measure output voltage by multimeter to (13.0-13.3)v



8. Check fuse pipe whether is damaged.

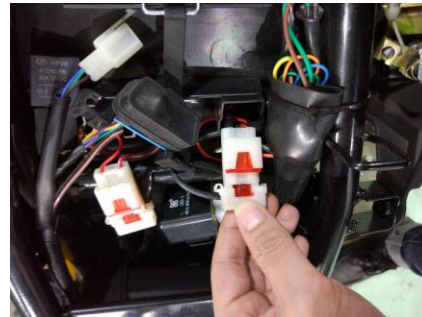

Major faults diagnosis

Phenomenon	Possible causes	Solutions
<ul style="list-style-type: none"> ● No electricity in the complete vehicle: ● Replace main fuse; ● While turning on with the key, the meter has no display, and other electrical functions do not work. 	<ul style="list-style-type: none"> ● Main fuse is blown; ● Main fuse circuits contact poorly; ● Accumulator's positive and negative poles contact poorly; ● No electricity in accumulator; ● Ignition switch failed; ● Ignition switch outgoing line and the main cable poorly plugged; ● The main cable related circuit open circuit or short circuit 	<ul style="list-style-type: none"> ● Replace main fuse ● Re-plug. ● Reconnect; ● Recharge or replace; ● Repair or replace; ● Re-plug. ● Repair or replace;
<ul style="list-style-type: none"> ● Low accumulator voltage: ● While powering on, the meter's voltage alarm lamp blinks; or the accumulator's terminal voltage is less than 12V. 	<ul style="list-style-type: none"> ● The vehicle has been stored for too long, and the accumulator has discharged automatically; ● Charging circuit fails in the complete vehicle. ● Accumulator fails to store charge. 	<ul style="list-style-type: none"> ● Recharge it with DC voltage stabilizing charger; ● Check the charging circuit. ● Replace accumulator.
<ul style="list-style-type: none"> ● Accumulator charges insufficiently; ● After the engine is started, the meter's voltage alarm lamp blinks; or the accumulator's terminal voltage is less than 13V. 	<ul style="list-style-type: none"> ● Variable voltage rectifier's outgoing line is poorly contacted or plugged with the main cable or magneto; ● Related lines of the main cable are open or shorted. ● Magneto fails; ● Variable voltage rectifier fails; ● Accumulator fails to store charge. 	<ul style="list-style-type: none"> ● Re-plug ● Repair or replace; ● Replace the magneto; ● Replace the variable voltage rectifier; ● Replace accumulator.
<ul style="list-style-type: none"> ● Accumulator overcharged; ● Large amount of air bubbles burst out from the accumulator. 	<ul style="list-style-type: none"> ● Variable voltage rectifier fails. 	<ul style="list-style-type: none"> ● Replace it.

15、 Starting system

Overview	Major parts and components
Circuit schematic drawing	Major faults diagnosis
Maintenance of starting system	

Overview

When the engine starts to work, an exogenous action is needed to help it run, thus entering the ignition & fuel supply procedure to enable the internal combustion engine to combust repeatedly and work steadily. YG125-30A motorcycle is only equipped with electric controlled starting. First, release it from the protection of shift position switch, side stand switch and clutch switch; then press down the start button to power on the relay, start the engine to drive the idle gear and starter gear, thus enabling the engine to enter its operating cycle for normal ignition, fuel injection and combustion. The system consists of the following components:

- Starting motor;
- Starting relay;
- Accumulator;
- Start switch and flameout switch;
- Neutral position switch and clutch switch.

Circuit schematic drawing

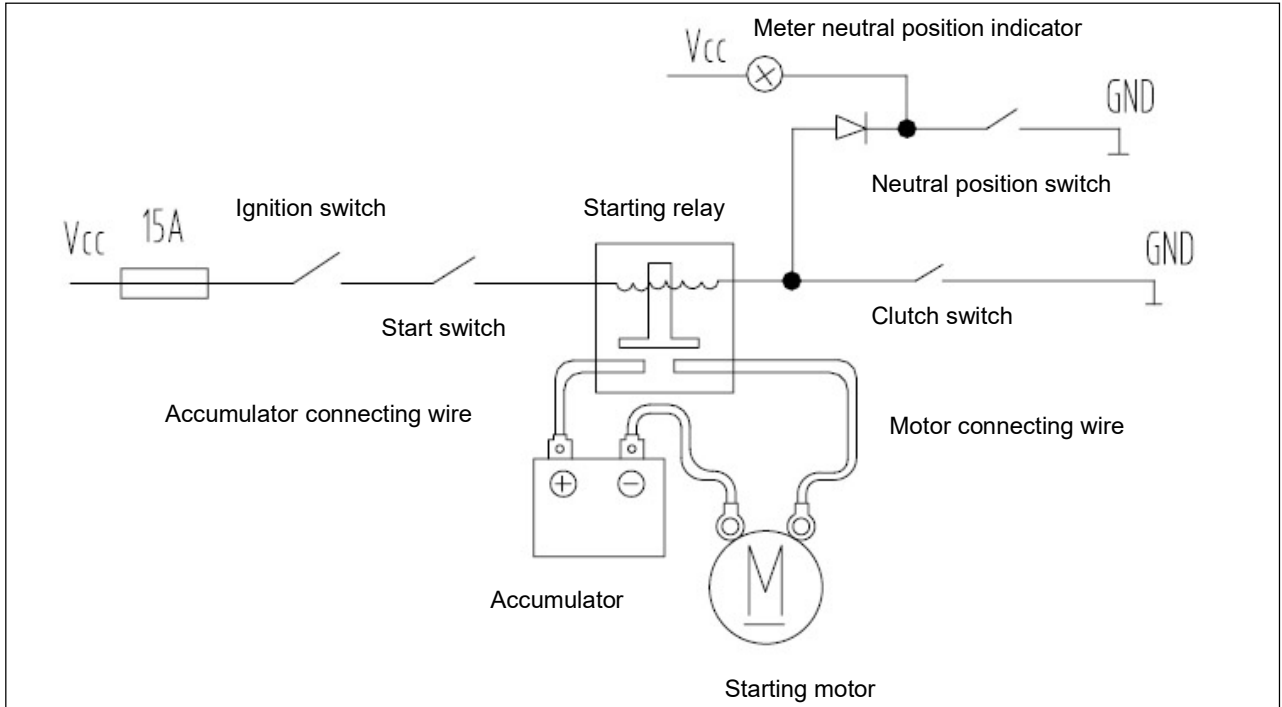

Maintenance of starting system

Disassemble, assemble and maintain

1. Turn on ignition switch and flameout switch to check electrical start whether energize.



2. Check plate electrode whether is damaged



3. Check charging coil of magneto whether is charged.



4. Check rectifier whether is charged.



5. Check fuse whether is burned.

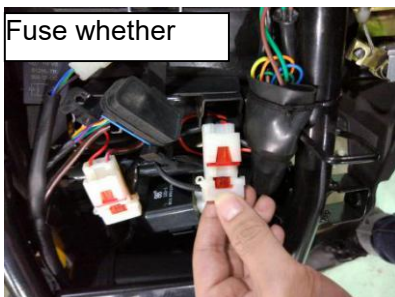

Fuse whether

6. Check positive and negative pole of battery whether contact well

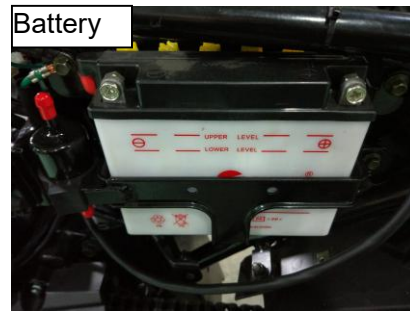

7. Check relay whether is damaged

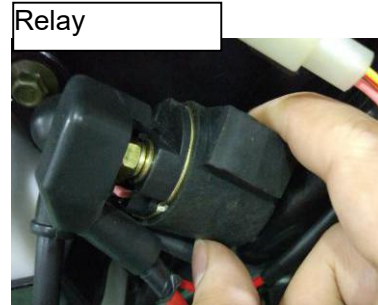

8. Check magneto coil whether contact well.

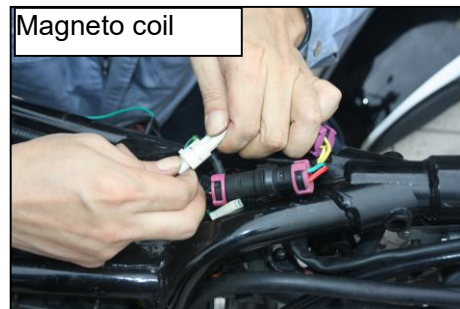

9. Check electrical starting switch whether contact well.



Starting switch

10. Turn on electrical starting button to check whether is rusted or energize.
11. Turn on flameout switch to check it whether is rusted or loose



12. Check switch plug of relay whether is loose.



13. Check clutch electrical starting switch plug whether is damaged or loose.

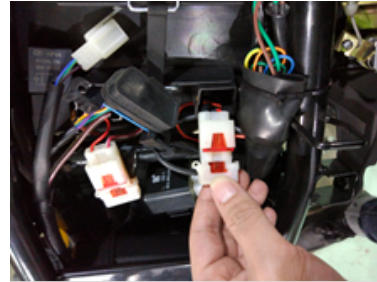

Major faults diagnosis

Phenomenon	Possible causes	Solutions
<ul style="list-style-type: none"> Starting relay doesn't attract; No sound of relay suction can be heard while pressing the start button, and the starting motor doesn't run. 	<ul style="list-style-type: none"> Accumulator voltage too low; Corresponding fuse is not connected or is blown; The Neutral line of the shift position switch is open circuit Clutch switch open circuit failure; Start button open failure; Flameout switch open circuit failure; Starting relay failed; Related lines of the main cable are open. 	<ul style="list-style-type: none"> Recharge the accumulator; Connect the fuse or replace it; Connect the line or replace shift position switch Connect the line or replace clutch switch Connect the line or replace the left switch; Connect the line or replace the left switch Replace the starting relay; Repair or replace main cable.
<ul style="list-style-type: none"> Starting motor doesn't rotate: there is the sound of relay suction, however, the motor doesn't rotate. 	<ul style="list-style-type: none"> Accumulator voltage too low; Heavy line connector lug slackened; Motor open circuit failure; Open circuit between the terminal contacts of the starting relay; Motor short circuit failure; Engine clogged, motor rotation jammed. 	<ul style="list-style-type: none"> Recharge the accumulator Fasten the connector lug; Replace the motor Replace the starting relay Replace the motor; Check the engine.
<ul style="list-style-type: none"> Motor rotating speed too low 	<ul style="list-style-type: none"> Accumulator voltage or capacity too low; Connector lug contacts poorly; Starting motor's output torque is insufficient; Motor resistance too large. 	<ul style="list-style-type: none"> Recharge or replace accumulator; Fasten the connector lug; Replace the motor; Check the engine.

16、 Illumination signal system

Overview	Major parts and components
Circuit schematic drawing	Major faults diagnosis

Overview

Illumination signal system is an important guaranty for the safe driving of the vehicle. It includes the headlamp illumination system, signal lamp control system and horn system.

Headlamp illumination system:

We need to use the headlamp to illuminate the road surface and inform the surrounding vehicles or people of its presence while driving at night; use the high-beam while driving at intermediate or high speed, and use the low-beam while meeting other vehicles; the low-beam shall be anti-dazzled

Signal lamp control systems:

In a turning drive, the vehicle shall prompt the surrounding vehicles and people to dodge by the flash of the turn lamp; while driving at night, it shall inform of its presence by the tail lamp's front / rear position lamp, and illuminate the number on the license plate; while braking, it shall illuminate the brake lamp to inform the vehicle behind of its braking deceleration. The flash of the turn lamp is controlled by a switch and a flasher, and the illuminations of other lamps are controlled only by a switch.

Horn system:

When there are other surrounding vehicles or pedestrians are or will likely hinder your driving, use horn to alert them for safe driving. The operation of the horn is controlled by the horn button.

Constituting parts and components:

- Head lamp
- Combined rear position lamp
- Horn
- Front brake lamp switch
- Rear brake lamp switch
- Left / Right combination switch

Circuit schematic drawing

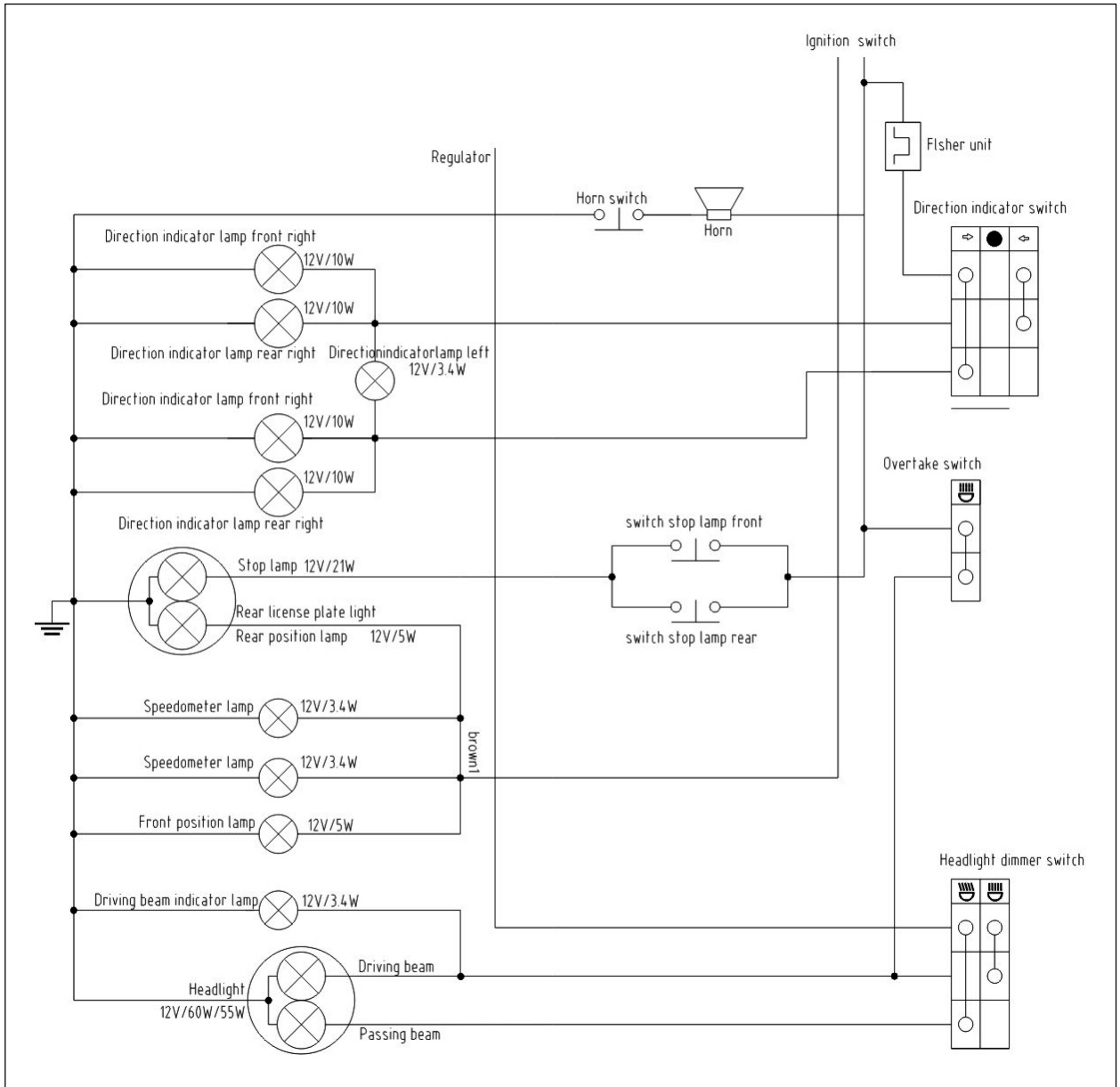

Maintenance of illumination system

1. Turn on ignition switch and flameout switch to check electrical start whether energize.



2. Open battery to check electrode plate whether is burned or electrolyte is little.



3. Check charging coil of magneto whether is charged.



4. Check rectifier whether is charged.

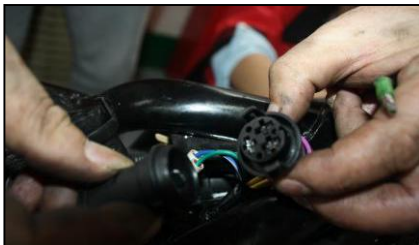

5. Check fuse whether is burned.

Fuse whether

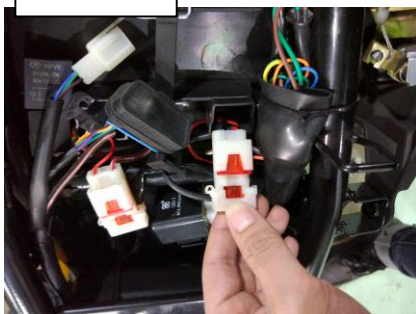

6. Take off headlamp switch socket to check whether there is current



7. Dismantle headlamp bolt to check lamp case whether is damaged.



8. Take out headlamp bulb to check it whether is burned

9. Mount bulb and holder to check headlamp whether it light

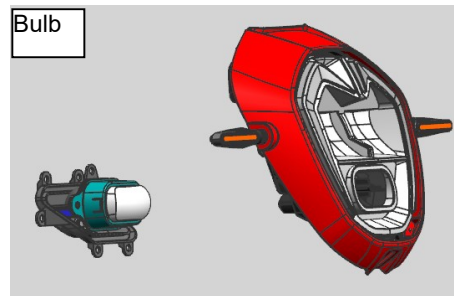

10. Take off remote, near lamp of headlamp and overtake lamp wire to check whether there are current or is loose.

11. Check headlamp ground wire whether is loose.

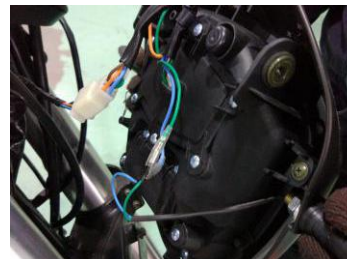

12. Dismantle taillight bolt to check lamp case whether is damaged.



13. Check tail lamp and brake lamp socket whether lose contact or bulb is burned



14. Take off ignition switch socket to check whether current input headlamp switch



15. Dismantle after brake lamp switch to check it whether lose contact.



16. Dismantle brake switch before to check it whether lose contact.

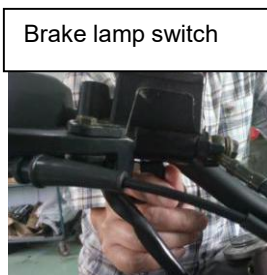

17. Check horn button whether is rusted or lose contact
Adjust velum of electrical horn to check it whether is damaged.



18. Check neutral socket whether contact well.



19. Signal lamp control systems

Check flasher whether is burned or plug is loose.



Turn on signal indication switch left handle to check switch whether is rusted or lose contact.



Check steering signal indication lamp socket whether lose contact or bulb is burned

20. Fuel level sensor

Check fuel sensor failed or float is blocked;

Line poorly plugged, open or short circuit.



Major parts and components

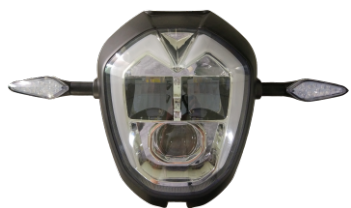

Head lamp



Combined rear position lamp



Horn

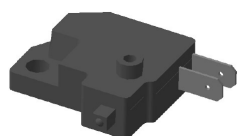

Front brake lamp switch



Rear brake lamp switch



Left combination switch

Right combination switch



Fuel level sensor

Major faults diagnosis

Phenomenon	Possible causes	Solutions
<ul style="list-style-type: none"> ● Headlamp does not illuminate; ● Hi-beam does not illuminate ● Low-beam does not illuminate ● Both do not illuminate 	<ul style="list-style-type: none"> ● Accumulator voltage too low; ● Corresponding fuse is not connected or is blown; ● Corresponding switch failed; ● Bulb failure; ● Poor plugging of line; ● Related lines of the main cable are open 	<ul style="list-style-type: none"> ● Recharge the accumulator; ● Connect the fuse or replace it; ● Repair or replace switch; ● Replace bulb; ● Re-plug; ● Repair or replace main cable.
<ul style="list-style-type: none"> ● Headlamp fails to illuminate reliably 	<ul style="list-style-type: none"> ● Poor contacting in fuse, bulb or lines; 	<ul style="list-style-type: none"> ● Reconnect the poorly contacted parts;
<ul style="list-style-type: none"> ● Headlamp illumination small 	<ul style="list-style-type: none"> ● Accumulator voltage too low; ● Line contact voltage drop too large; ● Headlamp body failed 	<ul style="list-style-type: none"> ● Recharge the accumulator; ● Repair the line; ● Replace headlamp
<ul style="list-style-type: none"> ● Position lamp doesn't illuminate: ● Front position lamp doesn't illuminate: ● Sidecar front / rear position lamp ● Tail lamp doesn't illuminate; ● Both do not illuminate 	<ul style="list-style-type: none"> ● Corresponding fuse is not connected or is blown; ● Position lamp switch failed; ● Bulb failure; ● Poor contact in lines; ● Related lines of the main cable are open 	<ul style="list-style-type: none"> ● Connect the fuse or replace it; ● Repair or replace the left switch; ● Replace bulb; ● Re-plug; ● Repair or replace main cable.
<ul style="list-style-type: none"> ● Brake lamp does not illuminate 	<ul style="list-style-type: none"> ● Corresponding fuse is not connected or is blown; ● Front brake lamp switch failed; ● Rear brake lamp switch failed; ● Bulb failure; ● Line failure 	<ul style="list-style-type: none"> ● Connect the fuse or replace it; ● Replace front brake lamp switch'; ● Adjust and replace rear brake lamp switch; ● Replace bulb ● Inspection / Repair
<ul style="list-style-type: none"> ● Horn does not sound 	<ul style="list-style-type: none"> ● Corresponding fuse is not connected or is blown; ● Horn button failed; ● Horn failed; ● Poor contact in lines; ● Related lines of the main cable are open. 	<ul style="list-style-type: none"> ● Connect the fuse or replace it; ● Repair or replace the left switch; ● Adjust or replace horn; ● Re-plug; ● Repair or replace main cable.
<ul style="list-style-type: none"> ● Turn signal lamp does not illuminate; ● Front turn lamp does not illuminate; ● Rear turn lamp does not illuminate; ● Both do not illuminate 	<ul style="list-style-type: none"> ● Accumulator voltage too low; ● Corresponding fuse is not connected or is blown; ● Left turn lamp switch failed; ● Right turn lamp switch failed; ● Flasher failed; ● Bulb failure; ● Poor contact in lines; ● Related lines of the main cable are open. 	<ul style="list-style-type: none"> ● Recharge the accumulator; ● Connect the fuse or replace it; ● Repair or replace the left switch; ● Repair or replace the left switch; ● Replace flasher; ● Replace bulb; ● Re-plug; ● Repair or replace main cable.

17、 Electrical starting control system

Overview	Major parts and components
Circuit schematic drawing	Major faults diagnosis

Overview

The information display system displays the dynamic and static information of the complete vehicle on the instrument panel for the driver's safe operation.

The complete vehicle information the YG125-30A displays include: vehicle speed, engine speed, fuel indicator, Neutral indicator, turn indication, high-beam indication, total / subtotal mileage traveled and EFI Indicator.

Constituting parts and components include:

- Combination meter
- Turn lamp
- Vehicle speed sensor
- Fuel level sensor
- Shift position switch
- Signal switch
- ECU

Circuit schematic drawing

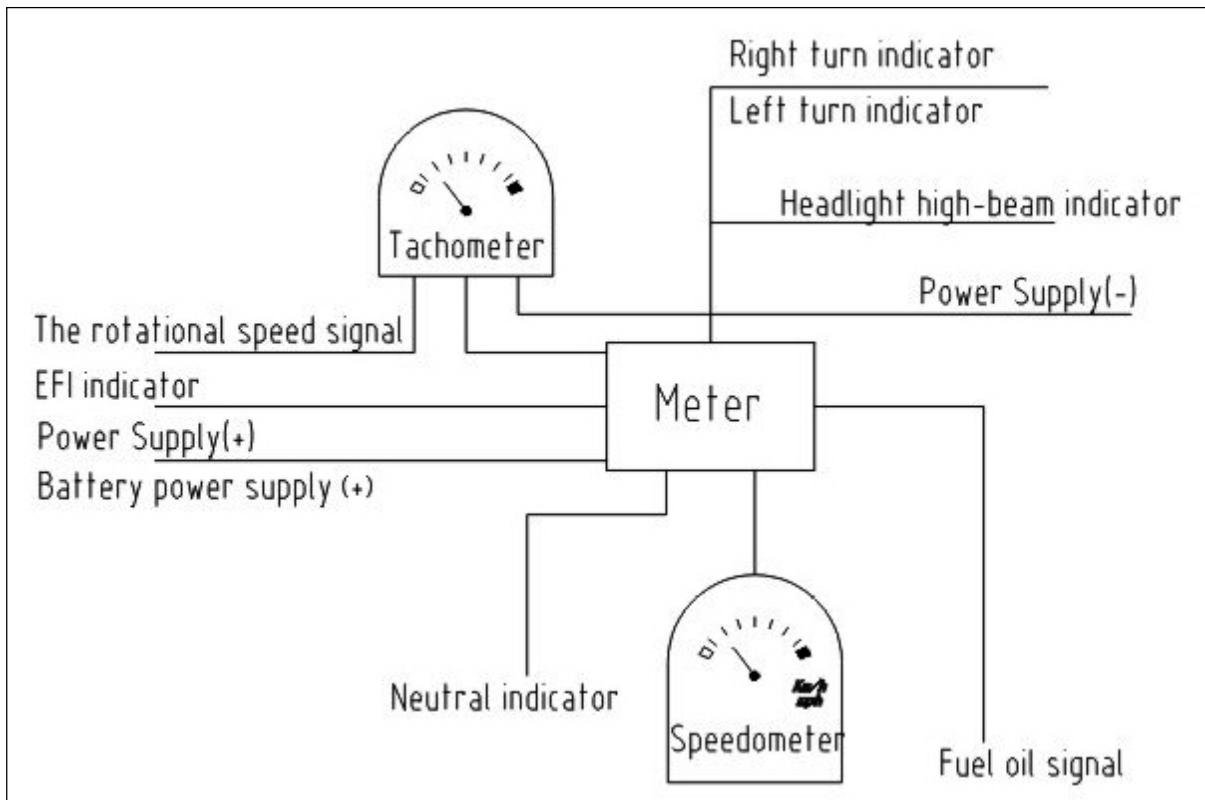

Major parts and components

○ Combination meter

1. Outline drawing



2. Line color function corresponding table

S/N	COLOUR	FUNCTION	S/N	COLOUR	FUNCTION
1	Black	Power Supply(+)	7	Green/ Red	Neutral indicator
2	green	Power Supply(-)	8	Black/ Yellow	The rotational speed signal
3	Brown	Instrument lighting	9	Yellow / white	Fuel oil signal
4	Blue	Headlight high-beam indicator	10	Red	Battery power supply (+)
5	Light blue	Right turn indicator	11	Green / Blue	EFI indicator
6	Orange	Left turn indicator			

3. Meter reading and usage

1) Speedometer

Indicate motorcycle speed (Km/h). Do not exceed legal rate-limiting to assure safe riding.

2) Odometer

Indicate riding distance (Km).

3) Turn indicator

⇒ (R) right turn, twinkle when turn to right(Green).

⇐ (L) left turn, twinkle when turn to left(Green).

4) Headlight high-beam indicator

≡ light on when Far light is switched on.

5) Neutral indicator

It is lit up when in the neutral position.

6) Tachometer

It shows the speed(rpm) of the engine.

7) Fuel gauge

Display tank fuel oil

8) Trip meter

It shows the mileage of trip in kilometers.

9) Trip meter knob

Indicate distance from Zero, by rotating Zero Knob to the Direction of Arrow can return it to Zero.

10) EFI Indicator

Indicating EFI system situation

Maintenance of electrical starting control system

1. Turn on ignition switch and flameout switch to check electrical start whether energize.



2. Check fuse whether is burned.

Fuse whether



3. Dismantle headlamp holder to check holder whether there is current.



4. Dismantle meter bolt to check it whether is loose or damaged.
5. Dismantle meter bolt and odometer cable to check bolt whether is damaged or loose.
6. Take off meter to check odometer, tachometer and fuel meter whether are damaged.



Major faults diagnosis

Phenomenon	Possible causes	Solutions
<ul style="list-style-type: none"> Winker indicator is out of work Meter dial illuminator is out of work Speedometer is out of work Tachometer of generator is out of work 	<ul style="list-style-type: none"> The winker indicator filament is burnt out The meter dial illuminator filament is burnt out The speedometer is damaged. Tachometer of generator is damaged. 	<ul style="list-style-type: none"> Replace winker indicator bulb Replace meter dial illuminatorbul Replace speed meter Replace tachometer
<ul style="list-style-type: none"> There is no mileage increasing indication upon vehicle speed 	<ul style="list-style-type: none"> Meter failed 	<ul style="list-style-type: none"> Replace meter
<ul style="list-style-type: none"> Speedometer is out of work 	<ul style="list-style-type: none"> Soft shaft is broken 	<ul style="list-style-type: none"> Replace speedometer soft shaft assembly
<ul style="list-style-type: none"> Engine speed indication failure 	<ul style="list-style-type: none"> Line poorly plugged or open circuit; Meter failed; ECU failed; 	<ul style="list-style-type: none"> Re-plug or repair; Replace meter; Replace ECU
<ul style="list-style-type: none"> Fuel level indication failure: No indication while there is fuel; Having indication while there is no fuel, 	<ul style="list-style-type: none"> Fuel sensor failed or float is blocked; Meter failed; Line poorly plugged, open or short circuit. 	<ul style="list-style-type: none"> Replace fuel sender; Replace meter; Re-plug or repair.
<ul style="list-style-type: none"> Meter backlight source doesn't illuminate 	<ul style="list-style-type: none"> Line poorly plugged or open circuit; Meter failed 	<ul style="list-style-type: none"> Re-plug or repair; Replace meter;
<ul style="list-style-type: none"> Meter can't communicate with ECU; 	<ul style="list-style-type: none"> Line poorly plugged or open circuit; Meter failed; ECU failed; 	<ul style="list-style-type: none"> Re-plug or repair; Replace meter. Replace ECU
<ul style="list-style-type: none"> Turn indicator filament is burnt out Headlight high-beam indicator filament is burnt out 	<ul style="list-style-type: none"> Line poorly plugged or open circuit; Meter failed; 	<ul style="list-style-type: none"> Re-plug or repair; Replace meter;
<ul style="list-style-type: none"> LCD fails to switch mode 	<ul style="list-style-type: none"> Meter failed 	<ul style="list-style-type: none"> Replace meter
<ul style="list-style-type: none"> Soft shaft is broken. 	<ul style="list-style-type: none"> 	<ul style="list-style-type: none"> Replace speedometer soft shaft assembly

18、 Engine management system

System Overview	Tools
Major parts and components	Maintenance depending on the malcode
Circuit schematic drawing	Maintenance depending on the performance
Maintenance of Engine management system	

System Overview

Components of system and Operating principle

The Engine Management System(EMS) comprises electronic control unit(ECU), throttle body, Idle speed control valve, fuel pump, fuel injector, ignition coil, O2 sensor, throttle position sensor, T-MAP sensor, cylinder head temperature sensor and so on. Based on the air flow and engine speed, the fuel injector and ignition coil are controlled by ECU to get the optimal combustible mixture of fuel and air and Ignition timing which meet all engine operating conditions. The EMS use sensors to collect parameters such as air flow, temperature of inlet air, cylinder head temperature, atmospheric pressure and the operation state of engine (rpm, load, acceleration and deceleration). All parameters are transferred to the ECU with electronic signal. The ECU output controlling signals after input signal are handled. Through the engine and actuators on the vehicle (ignition coil, fuel injector, Idle speed control valve and so on), the fuel and fire are exactly controlled and corrected with closed loop. For production conformity, corrected fuelling in order to match up to the difference of vehicles due to the inconformity of components.

System composition:

1. Sensor:
 - Intake air pressure sensor (load information) intake air temperature and pressure sensors
 - Throttle position sensor (load information, load range information, acceleration/deceleration information)
 - Engine speed sensor (speed information, crankshaft position)
 - Intake air temperature sensor (air density information)
 - Oxygen sensor (information of the excess air coefficient is more than 1 or less than 1)
2. Actuator:
 - Fuel pump relay,
 - Fuel pump
 - Fuel injector (fuel supply)
 - Ignition coil
 - High-tension cord
 - Spark plug (ignition)
 - Throttle, Idle speed control valve (air intake)
3. Electronic control unit
 - ECU

Major parts and components

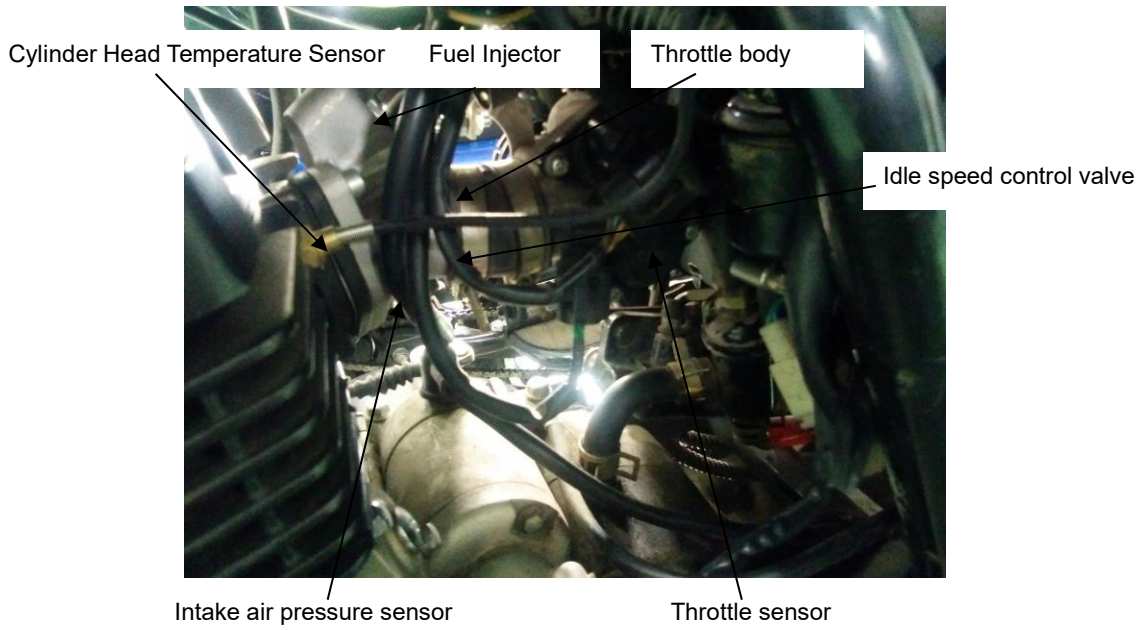

Electronic control unit(ECU)

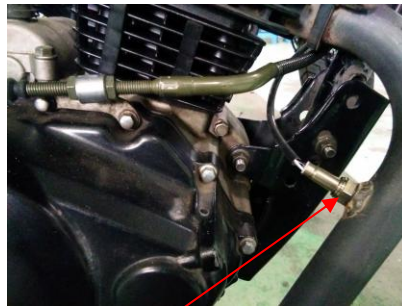

Oxygen sensor

Circuit schematic drawing

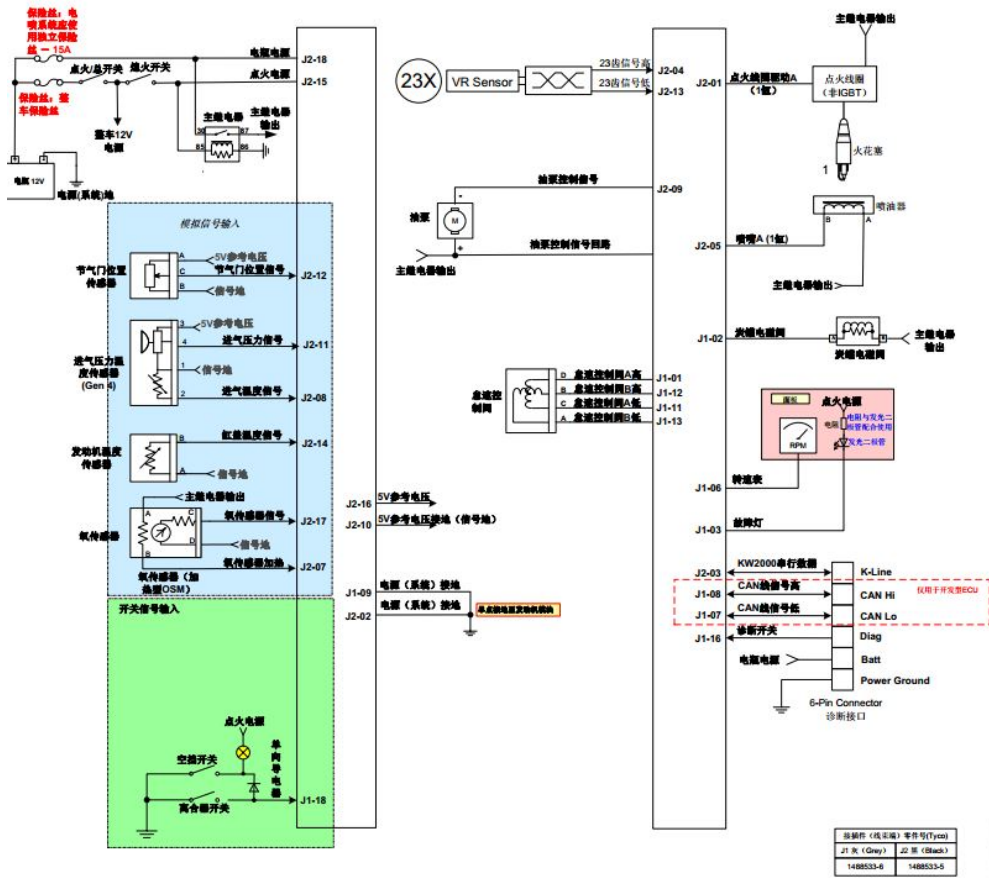

接插件	功能描述
J1-1	怠速控制阀A高
J1-2	共轨电磁阀
J1-3	故障灯
J1-4	
J1-5	
J1-6	转速表
J1-7	CAN线信号低
J1-8	CAN线信号高
J1-9	电源(系统)接地
J1-10	
J1-11	怠速控制阀A低
J1-12	怠速控制阀B高
J1-13	怠速控制阀B低
J1-14	
J1-15	
J1-16	诊断开关
J1-17	抽油泵控制信号回路
J1-18	空挡开关
J2-1	点火线圈驱动A(1缸)
J2-2	电源(系统)接地
J2-3	KW2000
J2-4	23齿信号高
J2-5	喷嘴A
J2-6	
J2-7	氧传感器加热
J2-8	进气压力信号
J2-9	抽油泵控制信号
J2-10	5V参考电压接地(信号地)
J2-11	进气压力信号
J2-12	节气门位置信号
J2-13	23齿信号低
J2-14	缸温度信号
J2-15	点火电源
J2-16	5V参考电压
J2-17	氧传感器信号
J2-18	电源(系统)

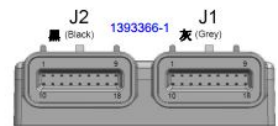

接插件 (线束端) 零件号(Tyco)
J1 束 (Grey) J2 束 (Black)
148853-6 148853-6

ITEM	PIN No.	DESCRIBE	ITEM	PIN No.	DESCRIBE
1	J1-1	IACAHi	1	J2-1	COILA
2	J1-2	MAGNETO CUT RELAY	2	J2-2	GND
3	J1-3	MIL	3	J2-3	KW2000
4	J1-4		4	J2-4	CRANK HI
5	J1-5		5	J2-5	INJA
6	J1-6	TACH	6	J2-6	
7	J1-7	CANLo	7	J2-7	O2AHTR
8	J1-8	CANHi	8	J2-8	IAT_MAT
9	J1-9	GND	9	J2-9	FUEL PUMP RELAY
10	J1-10		10	J2-10	5VRTN
11	J1-11	IACALo	11	J2-11	MAP
12	J1-12	IACBHi	12	J2-12	TPS
13	J1-13	IACBLo	13	J2-13	CRANK LO
14	J1-14		14	J2-14	CLT
15	J1-15		15	J2-15	IGN
16	J1-16	DIAG	16	J2-16	5VREF
17	J1-17	FUEL PUMP RECIRCULATION	17	J2-17	O2A
18	J1-18	PNSW	18	J2-18	VBATT

Maintenance of Engine management system

Because of the EFI, there are many possibilities for the engine issues. In other word, one issue may be caused by the mechanical problem or the EFI components. And the diagnostic tools cannot 100% indicate the root cause. So this manual shows the way to dig out the root cause with the help of the diagnostic tools.

Maintenance matters needing attention

- 1) Do not disassemble the components arbitrarily. It may damage the components if the water or the oil seep into the parts.
- 2) Turn the ignition off, before connect or disconnect the connectors.
- 3) Make sure the temperature of the ECU is below 80°C.
- 4) The fuel pressure is much high (about 250kPa), so please do not disassemble the fuel pipe arbitrarily. If have to, please release the pressure at first, and make sure the operation is delivered in the ventilated environment by the the professional maintenance persons.
- 5) When disassemble the fuel pump from the pump, make sure the power is off. Or it may casue the fire.
- 6) The fuel pump cannot work in air or water, it will shorten the service life. And the positive and negative connectors cannot be exchanged.
- 7) The ignition system check only could be delivered when it is nessasary. When check the spark plug out of the engine, if start the engine, please make sure the throttle is closed. Or too much unburned gasoline coming to the catalyst may damage the catalyst.
- 8) The idle speed is adjusted by the ECU. The idle pintle is not alowed to adjust.
- 9) The Positive and Negative of the battery cannot be reversed. It may damage the EFI components.
- 10) It is forbidden to remove the battery when the eninge is running.
- 11) Cannot measure the signal by pierce the harness.

Tools

- 1) Multimeter: measure the voltage, the resistance and the harness connection.
- 2) Diagnostic tool: reading the malfcode, and engine parameters.
- 3) Oil pressure garge: measure the fuel pressure.
- 4) Cylinder pressure garge: measure the pressure garge.

Maintenance depending on the malcode.**Description**

- 1) If the issue cannot repeat, the issue analysis may be wrong.
- 2) The multimeter below means the digital type. Pointer-type is forbidden.
- 3) If the malcode shows the voltage is low, it means maybe the wire is short to ground. If the malcode shows the voltage is high, it means maybe the wire is short to battery. If the malcode shows the components signal abnormal, it means the wire is open or short to other wires.

Diagnostic help:

- 1) If the malcode shows again after clearance, check whether the connector is connected well.
- 2) Do not ignore the affect of the engine maintenance situation, the cylinder pressure, and the mechanical ignition timing.
- 3) Change another ECU to do the test. If the malcode disappears, the root cause is the ECU. If the malcode is still there, then use the old ECU to do the test.

DTC List

System or Component	DTC Number	DTC Description	Related Calibration
Manifold Absolute Pressure Sensor (MAP)	P0107	MAP Circuit Low Voltage or Open	KsDGDM_MAP_ShortLow
	P0108	MAP Circuit High Voltage	KsDGDM_MAP_ShortHigh
Intake Air Temperature Sensor (IAT)	P0112	IAT Circuit Low Voltage	KsDGDM_IAT_ShortLow
	P0113	IAT Circuit High Voltage or Open	KsDGDM_IAT_ShortHigh
Coolant/Oil Sensor	P0117	Coolant/Oil Temperature Sensor Circuit Low Voltage	KsDGDM_CoolantShortLow
	P0118	Coolant/Oil Temperature Sensor Circuit High Voltage or Open	KsDGDM_CoolantShortHigh
Throttle Position Sensor (TPS)	P0122	TPS Circuit Low Voltage or Open	KsDGDM_TPS_ShortLow
	P0123	TPS Circuit High Voltage	KsDGDM_TPS_ShortHigh
Oxygen Sensor	P0131	O2S 1 Circuit Low Voltage	KsDGDM_O2_1_ShortLow
	P0132	O2S 1 Circuit High Voltage	KsDGDM_O2_1_ShortHigh
Oxygen Sensor Heater	P0032	O2S Heater Circuit High Voltage	KsDGDM_O2_1_HeaterShortHigh
	P0031	O2S Heater Circuit Low Voltage	KsDGDM_O2_1_HeaterShortLow
Fuel Injector	P0201	Injector 1 Circuit Malfunction	KsDGDM_INJ_CYL_A_Fault
	P0202	Injector 2 Circuit Malfunction	KsDGDM_INJ_CYL_B_Fault
Fuel Pump Relay (FPR)	P0230	FPR Coil Circuit Low Voltage or Open FPR	KsDGDM_FPP_CircuitShortLow
	P0232	FPR Coil Circuit High Voltage FPR	KsDGDM_FPP_CircuitShortHigh
Crankshaft Position Sensor (CKP)	P0336	CKP Sensor Noisy Signal	KsDGDM_CrankNoisySignal
	P0337	CKP Sensor No Signal	KsDGDM_CrankNoSignal
Ignition Coil	P0351	Cylinder 1 Ignition Coil Malfunction	KsDGDM_EST_A_Fault
	P0352	Cylinder 2 Ignition Coil Malfunction	KsDGDM_EST_B_Fault
Idle Control System	P0505	Idle Speed Control Error	KsDGDM_IdleControl
System Voltage	P0562	System Voltage Low	KsDGDM_SysVoltLow
	P0563	System Voltage High	KsDGDM_SysVoltHigh
MIL	P0650	MIL Circuit Malfunction	KsDGDM_MIL_Circuit
Tachometer	P1693	Tachometer Circuit Low Voltage	KsDGDM_TAC_Circuit_Low
	P1694	Tachometer Circuit High Voltage	KsDGDM_TAC_Circuit_High

Malcode: P0107

Information: MAP Circuit Low Voltage or Open

ITEM	OPERATION	RESULT	NEXT STEP
1	Connect the diagnostic tool, and ignition on.		Next
2	Check the data of 'BARO'. Make sure whether it is about 100kPa (depending on where you are)	Yes	Step 5
		No	Next
3	Remove the connector, and use the multimeter to check whether the voltage between pin B and D is about 5V.	Yes	Setp 5
		No	Next
4	Check whether the following pins is short to ground: J2-11, J2-10, J2-16 of the ECU and pin A, D, B of the connector.	Yes	Check the harness
		No	Next
5	Crank the engine to stay at idle. Check whether the MAP is about 30-50kPa. Then go to WOT, check whether the MAP goes to about 90kPa.	Yes	Diagnostoc help
		No	Change the sensor

Malcode: P0108

Information: MAP Circuit High Voltage

ITEM	OPERATION	RESULT	NEXT STEP
1	Connect the diagnostic tool, and ignition on.		Next
2	Check the data of 'BARO'. Make sure whether it is about 100kPa (depending on where you are)	Yes	Step 5
		No	next
3	Remove the connector, and use the multimeter to check whether the voltage between pin B and D is about 5V.	Yes	Setp 5
		No	Next
4	Check whether the following pins is short to battery: J2-11, J2-10, J2-16 of the ECU and pin A, D, B of the connector.	Yes	Check the harness
		No	Next
5	Crank the engine to stay at idle. Check whether the MAP is about 30-50kPa. Then go to WOT, check whether the MAP goes to about 90kPa.	Yes	Diagnostoc help
		No	Change the sensor

Malcode: P0112

Information: IAT Circuit Low Voltage

ITEM	OPERATION	RESULT	NEXT STEP
1	Connect the diagnostic tool, and ignition on.		Next
2	check whether the data of 'intake air temperature' equals to the real intake air temperature.	Yes	Setp 5
		No	Next
3	Remove the connector, and use the multimeter to check whether the resistance between pin B and D is reasonable according to the temperature.	Yes	Step 5
		No	Next
4	Remove the connector and check whether the voltage between pin B and D is about 5V.	Yes	Next
		No	Check harness
5	Check whether the following pins are short battery: J2-8, J2-10 of the ECU and pin C, D of the connector.	Yes	Change the harness
		No	Next
6	Crank the engine and stay idle. Check whether the 'intake air temperature' goes up when the engine temperature goes up.	Yes	Help
		No	Change the sensor.

Malcode: P0113

Information: IAT Circuit High Voltage

ITEM	OPERATION	RESULT	NEXT STEP
1	Connect the diagnostic tool, and ignition on.		Next
2	check whether the data of 'intake air temperature' equals to the real intake air temperature.	Yes	Setp 5
		No	Next
3	Remove the connector, and use the multimeter to check whether the resistance between pin B and D is reasonable according to the temperature.	Yes	Step 5
		No	Next
4	Remove the connector and check whether the voltage between pin B and D is about 5V.	Yes	Next
		No	Check harness
5	Check whether the following pins are short to ground or open: J2-8, J2-10 of the ECU and pin C, D of the connector.	Yes	Change the harness
		No	Next
6	Crank the engine and stay idle. Check whether the 'intake air temperature' goes up when the engine temperature goes up.	Yes	Help
		No	Change the sensor.

Malcode: P0117

Information: Coolant/Oil Temperature Sensor Circuit Low Voltage

ITEM	OPERATION	RESULT	NEXT STEP
1	Connect the diagnostic tool, and ignition on.		Next
2	check whether the data of 'engine temperature' equals to the real temperature.	Yes	Step 5
		No	Next
3	Remove the connector and use the multimeter to check whether the resistance between pin A and C of the sensor is reasonable according to the temperature.	Yes	Step 5
		No	Next
4	Use the multimeter to measure whether the voltage between A and C is about 5V.	Yes	Next
		No	Check the harness
5	check whether the following pins are short to gound or open: J2-10, J2-14 of the ECU and pin C and D of the sensor.	Yes	Harness issue
		No	Next
6	crank the engine and stay idle. Check whether the 'engine temperture' goes high when engine get warm.	Yes	Help
		No	Change the sensor

Malcode: P0118

Information: Coolant/Oil Temperature Sensor Circuit High Voltage or Open

ITEM	OPERATION	RESULT	NEXT STEP
1	Connect the diagnostic tool, and ignition on.		Next
2	check whether the data of 'engine temperature' equals to the real temperature.	Yes	Step 5
		No	Next
3	Remove the connector and use the multimeter to check whether the resistance between pin A and C of the sensor is reasonable according to the temperature.	Yes	Step 5
		No	Next
4	Use the multimeter to measure whether the voltage between A and C is about 5V.	Yes	Next
		No	Check the harness
5	check whether the following pins are short to battery or open: J2-10, J2-14 of the ECU and pin C and D of the sensor.	Yes	Harness issue
		No	Next
6	crank the engine and stay idle. Check whether the 'engine temperture' goes high when engine get warm.	Yes	Help
		No	Change the sensor

Malcode: P0122

Information: TPS Circuit Low Voltage or Open

ITEM	OPERATION	RESULT	NEXT STEP
1	Connect the diagnostic tool, and ignition on.		Next
2	Check whether the data of 'Throttle opening' is between 0%-1%.	Yes	Step 5
		No	Next
3	Open the throttle to 100% slowly, check whether the data of 'throttle opening' goes to between 90%-100%.	Yes	Step 5
		No	Next
4	Repeat Step 3, check whether the data jumps when open the throttle slowly.	Yes	Change the sensor
		No	Next
5	Remove the connector and check whether the following pins are short to ground or open: J2-12, J2-16 of ECU and pin A and C of the sensor.	Yes	Harness issue
		No	Next
6	Use multimeter to check whether the voltage between pin A and B is about 5V.	Yes	Help
		No	Step 5

Malcode: P0123

Information: TPS Circuit High Voltage

ITEM	OPERATION	RESULT	NEXT STEP
1	Connect the diagnostic tool, and ignition on.		Next
2	Check whether the data of 'Throttle opening' is between 0%-1%.	Yes	Step 5
		No	Next
3	Open the throttle to 100% slowly, check whether the data of 'throttle opening' goes to between 90%-100%.	Yes	Step 5
		No	Next
4	Repeat Step 3, check whether the data jumps when open the throttle slowly	Yes	Change the sensor
		No	Next
5	Remove the connector and check whether the following pins are short to battery: J2-12, J2-16 of ECU and pin A and C of the sensor.	Yes	Harness issue
		No	Next
6	Use multimeter to check whether the voltage between pin A and B is about 5V.	Yes	Help
		No	Step 5

Malcode: P0131/P0132

Information: O2S 1 Circuit Low/High Voltage

ITEM	OPERATION	RESULT	NEXT STEP
1	Connect the diagnostic tool, and ignition on.		Next
2	Use multimeter to check whether the connection between pin B of the oxygen sensor and pin J2-17 of the ECU is open, and whether the pin B of sensor is short to pin A.	Yes	Harness issue
		No	Next
3	Crank the engine and stay idle. When the engine gets warm, use multimeter to check whether the voltage between pin A and B keeps jumping between 100-900mV.	Yes	Help
		No	Next
4	A、 Emission pipe: block/leakage or not. B、 Injector: leakage or not C、 Fuel pressure too big or not D、 Valve clearance is to small or not	Yes	Engine maintenance
		No	Change sensor

Malcode: P0201

Information: Injector 1 Circuit Malfunction

ITEM	OPERATION	RESULT	NEXT STEP
1	Connect the diagnostic tool, and ignition on.		Next
2	Remove the conneter of injecor 1, use multimeter to check whether the voltage of Pin A is about 12V.	Yes	Step 4
		No	Next
3	Check whether the connection between pin A and the main power relay is short to ground or open.	Yes	Harness issue
		No	Next
4	Use multimeter to measure whether the resistance between pin A and B of the injecotr is about 10-14 Ω @ 20°C	No	Change the injector
		Yes	Next
5	Use the multimeter to check whether the voltage of Pin B is about 12V.	Yes	Help
		No	Next
6	Check whether the connection between pin B of the injector and J2-05 of the ECU is open or short to battery/ground.	Yes	Harness issue
		No	Help

Malcode: P0230/P0232

Information: FPR Coil Circuit Low/High Voltage or Open

ITEM	OPERATION	RESULT	NEXT STEP
1	Connect the diagnostic tool, and ignition off		next
2	Wait about 30s. Remove the fuel pump realy, ignition on. Check whether voltage of the relay feeder ear is about 12V	Yes	Change the pump
		No	Next
3	Check whether the feeder ear is short to ground or open.	Yes	Harness issue
		No	Help

Malcode: P0351

Information: Cylinder 1 Ignition Coil Malfunction

ITEM	OPERATION	RESULT	NEXT STEP
1	Connect the diagnostic tool, and ignition on.		next
2	Remove the connector and check whether the voltage of pin + is about 12V.	Yes	Step 4
		No	Next
3	Check whether the connection of the pin + and main power relay is open or short to ground.	Yes	Harness issue
		No	Next
4	Use multimeter to check wheter the resistance of the two coil pins is 0.5-0.65 Ω @20°C	Yes	Change coil
		No	Next
5	Use multimeter to check whether the voltage of pin B is about 12V.	Yes	Help
		No	Next
6	Check whether the connection of pin 2 of the coil and J2-01 of ECU is open or shor to battery/ground.	Yes	Harness issue
		No	Help

Malcode: P0505

Information: Idle Speed Control Error

ITEM	OPERATION	RESULT	NEXT STEP
1	Connect the diagnostic tool, and ignition off		next
2	Remove the connector. Use multimeter to check whether the resistance between pin A and pin D, pin B and pin C is about 53 \pm 5.3 Ω	Yes	Next
		No	Change stepper motor
3	Check whether the 4 wires are short to battery/ground or open.	Yes	Harness issue
		No	Help

Maintenance depending on the performance.

Before issue analysis, please check:

- 1) The MIL works well.
- 2) Clear the history malcode.
- 3) When the malcode comes again, note the conditions.

Check the appearance

- 1) Whether there is leakage of the fuel pipe or not.
- 2) Whether there is block/leakage or damage of the intake pipe.
- 3) Ageing level of the high-voltage cable.
- 4) Whether the ground connection is strong enough.
- 5) All the connectors connected well.

Note: if any item above exists, please do the fix it at first before issue analysis.

Diagnostic Help:

- 1) Make sure there is no any issue record of the engine.
- 2) Make sure the issue could repeat.
- 3) Have checked follow the instructions above and no cause found.
- 4) Do not ignore the maintenance situation, cylinder pressure, mechanical timing and fuel quality.
- 5) Change the ECU and repeat the test, if the issue is gone, then the root cause is the ECU. Or change the old one back to check the root cause.

ITEM	OPERATION	RESULT	NEXT STEP
Engine cannot start	Check whether the voltage of the battery is around 8-12V.	Yes	Next
		No	Change the battery.
	Crank the engine, and check whether the voltage is above 8V.	Yes	Next
		No	Change the battery.
	Check whether the start motor working well or not.	Yes	Next
		No	Change the start motor.
	If the issue only occurs in winter, check the oil and gear box oil.	Yes	Change the oil
		No	Next
	Check whether the engine rotation resistance is too big or not.	Yes	Check the enigne
		No	Help
	Check wether the fuel pump pressure is about 250kPa at idle.	Yes	Next
		No	Check the pump.
	Check whether the 'RMP' data on the diagnostic tool shows the real engine RPM.	Yes	Next
		No	Check the crank sensor.
	Pull out the spark plug, check whether the spark over is normal.	Yes	Next
		No	Check the ignition system
	Check whether the cylinder pressure is normal.	Yes	Engine is good.
		No	Check the engine

Start Difficult	Check whether the fuel pump pressure is about 250kPa at idle.	Yes	Next
		No	Check the pump.
	Pull out the spark plug, check whether the sparkover is normal.	Yes	Next
		No	Check the ignition system
	Remove the connector of the engine temperature sensor, and check whether the engine starts well.	Yes	Check the engine temperature sensor
		No	Next
	With a little bigger throttle, check whether the engine starts well.	Yes	Clean the throttle body and bypass channel.
		No	Next
	Pull out the injector, and crank the engine. Check whether the injection is normal.	Yes	Next
		No	Clean or change the injector.
	Pull out the spark plug, check whether it is wet or not	Yes	dry the plug and combustion chamber.
		No	Next
Check whether the cylinder pressure is normal or not	Yes	Engine is good	
	No	Check the engine	
Unstable idle	Check whether the air filter is blocked and whether the intake pipe leaks.	Yes	Intake system maintenance
		No	Next
	Whether there is carbon deposit at the throttle body and bypass channel.	Yes	Clean the TB
		No	Next
	Check whether the IACV works well	Yes	Next
		No	Check the IACV
	Check whether the fuel pressure is about 250kPa.	Yes	Next
		No	Check the pump
	Check whether the injector is blocked.	Yes	Clean or change the injector
		No	Next
	Make sure using the right type spark plug	Yes	Next
		No	Change the spark plug
	Check whether the cylinder pressure is normal	Yes	Next
		No	Check the engine
	Remove the engine temperature sensor, and check whether the engine works well	Yes	Change the sensor
		No	Next
	Remove the TPS, check whether the engine works well	Yes	Change the sensor
		No	Help
High idle	Check whether the throttle cable is stuck	Yes	Adjust the cable
		No	Next
	Check whether the idle pintle has been adjusted	Yes	Change the TB
		No	Next
	Check whether there is any leakage of the intake pipe.	Yes	Maintenance
		No	Next
	Check whether the IACV works well	Yes	Next
		No	Change IACV
	Remove the engine temperature sensor and check whether the	Yes	Help

	engine works well	No	Change the sensor
Acceleration gets worse	Check whether the air filter is blocked and whether the intake pipe leaks.	Yes	Intake system maintenance
		No	Next
	Check whether the fuel pressure is about 250kPa.	Yes	Next
		No	Check the pump
	Pull out the sprk plug, check whether it is wet or not	Yes	dry the plug and combustion chamber.
		No	Next
	Check whether the TMAP, TPS and the connections works well.	Yes	Next
		No	Change the sensor or harness maintenance
	Check whether the injeoctor is blocked.	Yes	Clean or change the injector
		No	Next
	Check the typ and the clearance of the spark plug.	Yes	Next
		No	Change the sprk plug
Check whether the cylinder pressure is normal	Yes	Next	
	No	Check the engine	
Check whether the exhaust pipe is blocked or not	No	help	
	Yes	maintenance	
Backfire	Pull out the spark plug, check whether the sparkover is normal.	Yes	Next
		No	Check the ignition system
	Check whether the timing is right	Yes	Next
		No	Adjust the timing
	Check whether there is leakage of the valve	Yes	Adjust the valve
		No	Next
	Check whether the injeoctor is blocked.	Yes	Clean or change the injector
		No	Next
Check whether the oxygen sensor works well	Yes	Help	
	No	Change the sensor	
Miss fire	Pull out the spark plug, check whether the sparkover is normal.	Yes	Next
		No	Check the ignition system
	Check whether the timing is right	Yes	Next
		No	Adjust the timing
	Check the typ and the clearance of the spark plug.	Yes	Help
		No	Change the sprk plug

19、Electrical System Diagram

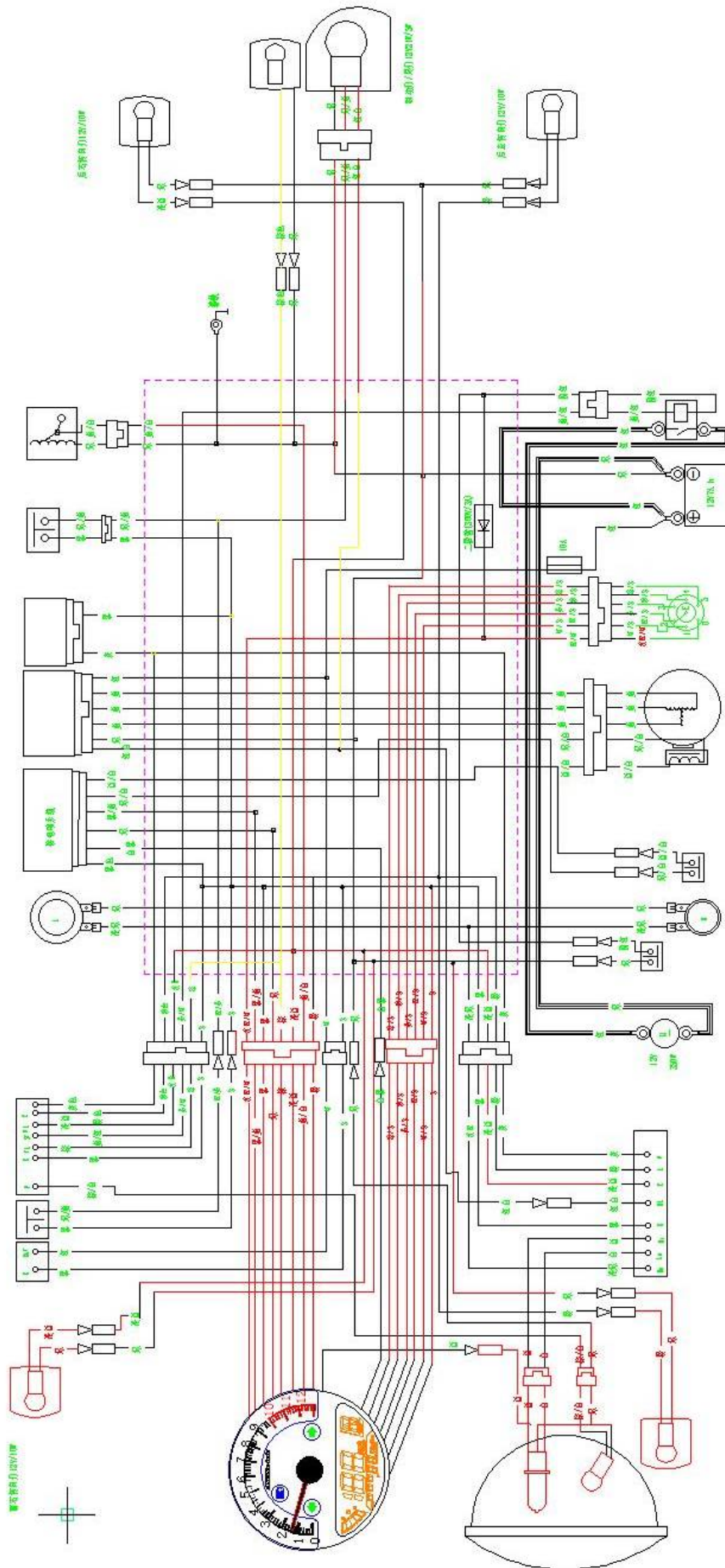

YG50Q-8

YG50Q-8 Maintenance Manual

first edition

Mar. 2021

The copyright is owned by the company ;
and shall not be copied or reproduced without permission



Chongqing YINGANG technology group co., LTD

Address: No. 71 tongxing nan road, beibei district, chongqing, China

Tel: 400-809-6638

URL: <http://www.cqyingang.com>